

CALIFORNIA COMMERCIAL DRIVER HANDBOOK



This handbook is available at dmv.ca.gov.

Gavin Newsom, Governor
State of California

Toks Omishakin, Secretary
California State Transportation Agency

Steve Gordon, Director
California Department of Motor Vehicles

**THIS PAGE LEFT
INTENTIONALLY
BLANK**

CALIFORNIA DRIVER LICENSE CLASSES

You May Drive With a

Commercial Class A Driver License:

- Any legal combination of vehicles, including vehicles under Class B and Class C

Noncommercial Class A Driver License:

- Any vehicle under Class C
- Any housecar over 40 feet but not over 45 feet

Commercial Class B Driver License:

- A single vehicle with a GVWR or GVW of more than 26,000 pounds
- A 3 or more axle vehicle weighing over 6,000 pounds
- A bus (except a trailer bus) with a GVWR or GVW of more than 26,000 pounds, with endorsement
- Any farm labor vehicle, with endorsement
- All vehicles under Class C

Noncommercial Class B Driver License:

- Any vehicle under Class C
- Any housecar over 40 feet but not over 45 feet with endorsement

Basic Class C Driver License:

- A 2-axle vehicle with a GVWR or GVW of 26,000 pounds or less
- A 3-axle vehicle weighing 6,000 pounds gross or less
- A motorized scooter
- Any housecar 40 feet or less
- A farmer or employee of a farmer may also drive any combination of vehicles with a gross combination weight rating (GCWR) of 26,000 pounds or less if used exclusively in agricultural operations **and** not for hire or compensation

Commercial Class C Driver License:

- A bus (except a trailer bus) with a GVWR or GVW of 26,000 pounds or less, with endorsement
- Any Class C vehicle carrying hazardous materials (HazMat) which requires placards, with a HazMat endorsement on their license as defined by CVC §§3553 and 15278
- A single vehicle designed to transport liquid or gaseous materials in a tank or tanks having an individual rated capacity of more than 119 gallons and aggregate rated capacity of 1,000 gallons or more that is permanently or temporarily attached to the vehicle or chassis with a GVWR or GVW of 26,000 pounds or less, with endorsement

Motorcycle Class M1 Driver License:

- 2-wheel motorcycle, motor-driven cycle, or motorized scooter

Motorcycle Class M2 Driver License:

- Motorized bicycle, moped, bicycle with an attached motor, or motorized scooter

And You May Tow a

- Single vehicle with a gross vehicle weight rating (GVWR) or gross vehicle weight (GVW) of more than 10,000 pounds.
- Trailer bus, with endorsement
- More than one vehicle, with endorsement.
- Vehicle under Class B and Class C.

- Trailer coach weighing over 10,000 pounds GVWR, not used for hire.
- Fifth-wheel travel trailer weighing over 15,000 pounds GVWR, not used for hire.

If the towing vehicle weighs 4,000 pounds or more unladen, you may tow a livestock trailer exceeding 10,000 pounds GVWR but not exceeding 15,000 pounds GVWR if all of the following conditions are met and the vehicle is:

- Controlled and operated by a farmer used to transport livestock to or from a farm.
- Not used in the operations of a common commerce or contract carrier.
- Used within 150 miles of the person's farm.

- Single vehicle with a GVWR or GVW of 10,000 pounds or less.
- Vehicle under Class C.

- Single vehicle with a GVWR of 10,000 pounds or less, including a tow dolly, if used.

- Trailer coach or fifth-wheel travel trailer under 10,000 pounds GVWR when towing is not for compensation.

- Fifth-wheel travel trailer exceeding 10,000 pounds but not exceeding 15,000 pounds GVWR, when towing is not for compensation and with endorsement.

If the towing vehicle weighs 4,000 pounds or more unladen, you may tow a trailer coach not exceeding 9,000 pounds gross.

Note: No passenger vehicle, regardless of weight, may tow more than one vehicle. No motor vehicle under 4,000 pounds unladen may tow any vehicle weighing 6,000 pounds or more gross (CVC §21715).

Examples

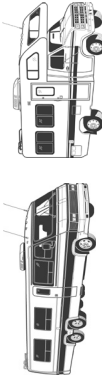
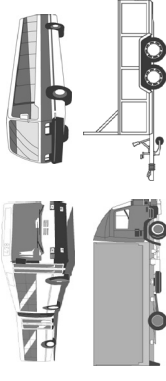
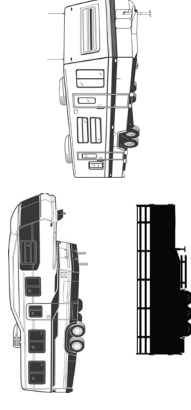
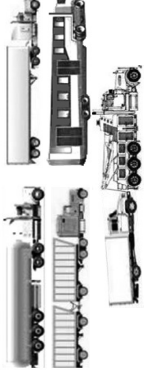

**THIS PAGE LEFT
INTENTIONALLY
BLANK**

TABLE OF CONTENTS

SECTION 1: INTRODUCTION	1-1
1.1 – CDL Tests	1-10
1.2 – Medical Documentation Requirements	1-12
1.3 – CDL Disqualifications	1-14
1.4 – Other CDL Rules	1-16
1.5 – International Registration Plan and International Fuel Tax Agreement.....	1-28
SECTION 2: DRIVING SAFELY	2-1
2.1 – Vehicle Inspection	2-1
2.2 – Basic Control of Your Vehicle	2-9
2.3 – Shifting Gears.....	2-10
2.4 – Seeing	2-12
2.5 – Communicating	2-14
2.6 – Controlling Your Speed.....	2-15
2.7 – Managing Space	2-19
2.8 – Seeing Hazards.....	2-21
2.9 – Distracted Driving	2-24
2.10 – Aggressive Drivers/Road Rage	2-27
2.11 – Driving at Night	2-28
2.12 – Driving in Fog	2-32
2.13 – Driving in Winter	2-32
2.14 – Driving in Very Hot Weather	2-34
2.15 – Railroad-Highway Crossings	2-35
2.16 – Mountain Driving	2-37
2.17 – Driving Emergencies	2-38
2.18 – Anti-lock Braking Systems (ABS)	2-41
2.19 – Skid Control and Recovery.....	2-42
2.20 – Accident Procedures	2-44
2.21 – Fires	2-44
2.22 – Alcohol, Other Drugs, and Driving ...	2-46
2.23 – Hazardous Materials Rules for All Commercial Drivers.....	2-48
SECTION 3: TRANSPORTING CARGO SAFELY	3-1
3.1 – Inspecting Cargo	3-1
3.2 – Cargo Weight and Balance.....	3-1
3.3 – Securing Cargo	3-2
3.4 – Cargo Needing Special Attention	3-4
SECTION 4: TRANSPORTING PASSENGERS SAFELY	4-1
4.1 – Vehicle Inspection	4-1
4.2 – Loading and Trip Start	4-2
4.3 – On the Road	4-4
4.4 – After-Trip Vehicle Inspection.....	4-5
4.5 – Prohibited Practices	4-6
4.6 – Use of Brake-Door Interlocks	4-6
SECTION 5: AIR BRAKES	5-1
5.1 – Parts of an Air Brake System	5-1
5.2 – Dual Air Brake	5-6
5.3 – Inspecting Air Brake Systems.....	5-7
5.4 – Using Air Brakes.....	5-11
SECTION 6: COMBINATION VEHICLES	6-1
6.1 – Driving Combination Vehicles Safely...	6-1
6.2 – Combination Vehicle Air Brakes	6-5
6.3 – Anti-lock Brake Systems.....	6-8
6.4 – Coupling and Uncoupling	6-9
6.5 – Inspecting a Combination Vehicle	6-16
SECTION 7: DOUBLES AND TRIPLES	7-1
7.1 – Pulling Double/Triple Trailers.....	7-1
7.2 – Coupling and Uncoupling	7-2
7.3 – Inspecting Doubles and Triples	7-4
7.4 – Doubles/Triples Air Brake Check.....	7-5
SECTION 8: TANK VEHICLES	8-1
8.1 – Inspecting Tank Vehicles	8-1
8.2 – Driving Tank Vehicles	8-2
8.3 – Safe Driving Rules.....	8-3

SECTION 9: HAZARDOUS MATERIALS ... 9-1
 9.1 – Intent of the Regulations 9-3
 9.2 – Hazardous Materials
 Transportation—Who Does What..... 9-3
 9.3 – Communication Rules 9-4
 9.4 – Loading and Unloading9-11
 9.5 – Bulk Packaging Marking, Loading,
 and Unloading 9-15
 9.6 – Hazardous Materials —
 Driving and Parking Rules 9-16
 9.7 – Hazardous Materials —
 Emergencies 9-19
 9.8 – Hazardous Materials — Glossary..... 9-24

SECTION 10: SCHOOL BUSES 10-1
 10.1 – Danger Zones and Use of Mirrors ... 10-1
 10.2 – Loading and Unloading 10-3
 10.3 – Emergency Exit and Evacuation 10-7
 10.4 – Railroad-Highway Grade
 Crossings 10-8
 10.5 – Student Management10-11
 10.6 – Anti-lock Braking Systems10-11
 10.7 – Special Safety Considerations 10-12

**SECTION 11: VEHICLE INSPECTION
 TEST11-1**
 11.1 – All Vehicles.....11-1
 11.2 – Internal Inspection
 (All Vehicles).....11-1
 11.3 – External Inspection
 (All Vehicles).....11-5
 11.4 – School Bus Only11-9
 11.5 – Trailer11-10
 11.6 – Coach/Transit Bus11-10
 11.7 – Taking the CDL Vehicle Inspection
 Test..... 11-11

**SECTION 12: BASIC CONTROL SKILLS
 TEST 12-1**
 12.1 – Skills Test Scoring 12-1
 12.2 – Skills Test Exercises 12-2

SECTION 13: ROAD TEST 13-1
 13.1 – How You Will Be Tested..... 13-1

This material is based upon work supported by the Federal Motor Carrier Safety Administration under Cooperative Agreement No. DTFH61-97-X-00017. Any opinions, findings, conclusions or recommendations expressed in this publication are those of the Author(s) and do not necessarily reflect the view of the Federal Motor Carrier Safety Administration.

© Copyright, Department of Motor Vehicles 2019-2021

All rights reserved

This work is protected by U. S. Copyright Law. DMV owns the copyright of this work. Copyright law prohibits the following: (1) reproduction of the copyrighted work; (2) distribution of copies of the copyrighted work; (3) preparation of derivative works based upon the copyrighted work; (4) displaying the copyrighted work publicly; or (5) performing the copyrighted work publicly. All requests for permission to make copies of all or any part of this publication should be addressed to:

*Department of Motor Vehicles
 Legal Office, MS C128
 PO Box 932382
 Sacramento, CA 94232-3820*

SECTION 1: INTRODUCTION

THIS SECTION COVERS

- 1.1 – CDL Tests
- 1.2 – Medical Documentation Requirements
- 1.3 – CDL Disqualifications
- 1.4 – Other CDL Rules
- 1.5 – International Registration Plan and International Fuel Tax Agreement

There is a federal requirement that each state have minimum standards for licensing of commercial drivers.

The California Commercial Motor Vehicle Safety Program was enacted to improve traffic safety on our roadways. As a result, California has developed licensing and testing requirements for drivers of commercial vehicles that equals or exceeds federal standards.

This handbook provides driver license (DL) testing information for drivers who wish to have a commercial learner's permit (CLP)/commercial driver license (CDL). This handbook does **not** provide information on all the federal and state requirements needed before you can drive a commercial motor vehicle (CMV). More information may be found in Title 49, *Code of Federal Regulations* (CFR) or *California Vehicle Code* (CVC).

WHO NEEDS A CDL

You Must Have a CDL to Operate:

- A single vehicle with a gross vehicle weight rating (GVWR) of 26,001 pounds or more.
- A combination of vehicles with a gross combination weight rating (GCWR) of 26,001 pounds or more.
- A vehicle designed, used, or maintained for carrying more than 10 passengers, including the driver (see chart below).
- A 3-axle vehicle weighing more than 6,000 pounds.

You Must Have a CDL When:

- Towing a vehicle or trailer, which has a GVWR of 10,001 pounds or more.
- Transporting hazardous materials (HazMat), which require placards.
- Transporting HazMat, as defined in *California Health and Safety Code* (CHSC) §§25115 and 25117.
- Towing any combination of 2 trailers or vehicle and trailer.

Horse trailers with living quarters and a GVWR over 10,000 pounds require a commercial Class A DL. Restriction 88 will be added to the DL if the truck and trailer GCWR is under 26,001 pounds.

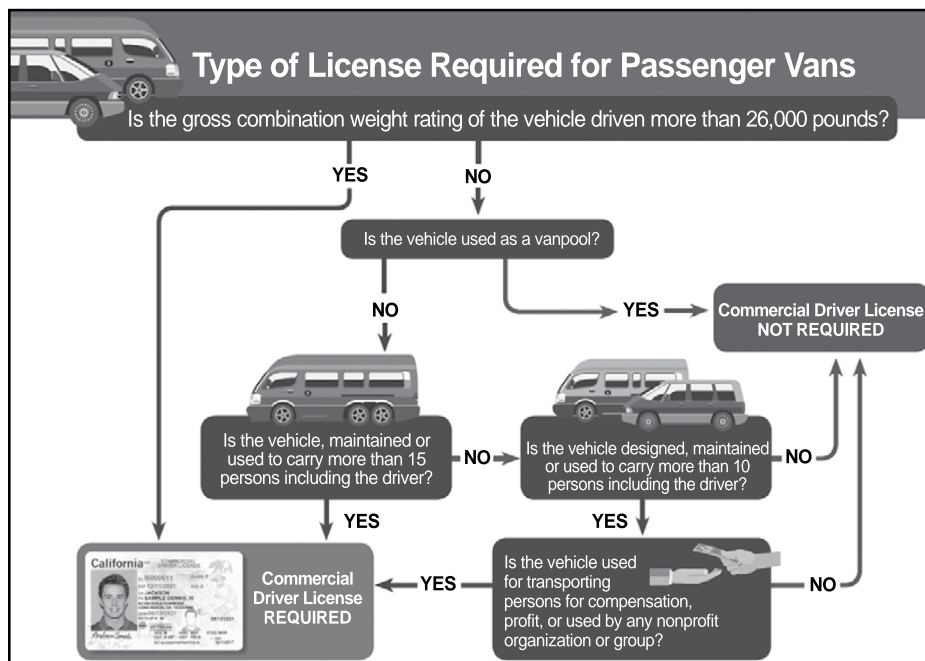

Restriction 88 – restricted to combination vehicles with a GCWR of less than 26,001 pounds and the GVWR of the vehicle(s) being towed is in excess of 10,000 pounds.

Horse trailers are defined as property carrying vehicles and the addition of “living quarters” to a trailer **does not** permanently alter that vehicle for human habitation. The “living quarters” are secondary or incidental to the primary function of the vehicle, which is transporting property.

HOW TO GET A CLP/CDL

Commercial Learner’s Permit (CLP)

The commercial instruction permit has been renamed CLP to comply with federal regulations. The CLP:

- Applicant must be at least 18 years of age.
- Will not be issued to an applicant until they have obtained a valid California DL that, at a minimum, allows the applicant to operate a non-commercial Class C motor vehicle. A temporary California DL is acceptable.
- Is only valid when accompanied by the CLP holder’s valid California DL.
- Will be valid for a maximum of 180 days from the date of issuance and may be renewed for up to an additional 180 days, provided the CLP expiration date does not exceed a period of 1 year from the initial application date.
- Is limited to the following endorsements:
 - Tank (N).
 - Passenger (P).
 - School Bus (S).
- Holder with an “N” endorsement is prohibited from operating a tank vehicle unless the tank is empty. The tank must be purged if it previously contained HazMat.
- Holder with a “P” endorsement and/or “S” endorsement is prohibited from operating a CMV with passengers, other than federal/state auditors and inspectors, test examiners, other trainees, and the accompanying CDL holder.
- Holder must wait a minimum of 14 days after initial CLP issuance to be eligible to take the skills test. The 14-day waiting period applies to classification upgrades and endorsement/restriction changes that require a skills test.

- Holder must be accompanied by a CDL holder while operating a CMV. The CDL holder must possess the appropriate class CDL and endorsements necessary to operate the CMV.
- Holder must surrender their CLP and DL to DMV prior to being issued a CDL.

Applicants Applying for a CDL

- Must be 18 years of age.
- Must obtain a California Noncommercial Class C DL (a temporary/interim DL is acceptable). The DL must be carried to validate the CLP (CFR, Title 49 §§383.5 and 383.25).
- May drive for hire within California if you are 18 years of age or older and do not engage in interstate commerce activities.
- Must be at least 21 years old to drive a commercial vehicle engaged in interstate commerce or transport HazMat or wastes (intrastate or interstate commerce) (CVC §12515).

Provide the Following Items:

- **A completed Commercial Driver License Application** (DL 44C/eDL 44C) form. The eDL 44C may be completed online in advance. Signing this form means you agree to submit to a chemical test to determine the alcohol or drug content of your blood when requested by a peace officer. If you refuse to sign this form, the Department of Motor Vehicles (DMV) will not issue or renew your DL.
- **Your true full name.**
- **Approved Medicals** – (See Section 1.2)
- **An acceptable identity (birth date/legal presence) document.** All applicants for an original, renewal, upgrade, or transfer of their CLP/CDL must submit proof of legal presence in the U.S. as authorized under federal law.
 - If the name on your identity document is different from the name on your CDL application, you must also submit an acceptable true full name document.
 - Your true full name, as shown on your identity document, will appear on your CLP/CDL.

FEES SUBJECT TO LEGISLATIVE CHANGE EACH JANUARY 1.

Fees shown are effective January 1, 2020. See dmv.ca.gov for current fees.

If the class of license is...	and the application type is...	the fee is...
Commercial Class A or B	an original (with/without a driving test)	\$82
	a renewal	\$48
	a commercial driving or skill retest	\$37
	a duplicate (replacement) license	\$36
	a name change	\$30
	to remove a restriction(s) imposed due to vehicle size or equipment (DT required)	\$82
	add an endorsement other than PV	\$48
	add a passenger transport endorsement (PV)	\$82
	add noncommercial Class A to a Class B	\$37
	add a motorcycle license (Class M1 or M2)	\$48
	add a firefighter endorsement	\$30
Commercial Class C	an original (with/without a driving test)	\$48
	a renewal	\$48
	an upgrade:	
	to remove an air brake restriction (DT required)	\$48
	to add an endorsement not requiring a driving test	\$48
	to add a motorcycle license (Class M1 or M2)	\$48
	to add a Firefighter endorsement	\$30
	a commercial driving or skill retest	\$37
a duplicate (replacement) license	\$36	
a name change	\$30	

- An acceptable identity or true full name document is produced by an issuing authority (for example, county, state, etc.).
 - This document is a certified copy of the original (the original is always retained by the issuing authority) and contains an impressed seal or original stamped impression.
 - The certified copy will be returned to you.
 - If you make a copy of the certified copy, DMV will **not** accept it for identity verification.
- For more information on acceptable identity documents, visit dmv.ca.gov or call 1-800-777-0133.

- **Residency (Domicile).** A California driver **must** provide **1 document** as proof of California residency for original and upon **each renewal, transfer, or upgrade**. The address on the residency document must match the residence address on the DL 44C. For more information on acceptable residency documents or REAL ID Compliant CLP/CDL, visit dmv.ca.gov or call 1-800-777-0133.
 - **Provide proof of your social security number.** Your social security number (SSN) will be verified with the Social Security Administration while you are in the office. For more information on social security documents, visit dmv.ca.gov or call 1-800-777-0133.
- NOTE:** If you are applying for an original CDL (REAL ID or federal non-compliant), a social security card is the only acceptable proof of SSN.

- **A Certificate of Driving Skill (DL 170 ETP).** If your employer is authorized by DMV to issue such certificate, both you and your employer **must** sign this form.
- **The application fee.** This fee is good for 12 months from the application date. The CLP is good for a maximum of 180 days and may be renewed for an additional 180 days without retaking the knowledge tests, provided the expiration date of the CLP does **not** exceed a period of 1 year from the application date. Scores for passed segments of the skills test are only valid during the initial issuance (first 180 days) of the CLP. Passed segments of the skills test (vehicle inspection, basic control skills, and road test) **must** be retaken if the CLP is renewed.

You are allowed 3 attempts to pass the knowledge test(s) and a total of 3 attempts to pass the entire skills test on a single application. If you fail any knowledge test(s) there is not a waiting period to retake. If you fail any segment of the skills tests (vehicle inspection, basic control skills, or road test), it will count as 1 failure towards the maximum 3 attempts you are allowed. **EXAMPLE:** Failing the vehicle inspection, basic control skills, and road test counts as a 3-time failure (or any failure combination equaling 3). However, if you are required to take the skills test for separate types of vehicles (Class A or passenger transport vehicle), you are allowed 3 skills test attempts for the Class A vehicle and 3 skills test attempts for the passenger transport vehicle. If you fail the basic skills test or the road test, there will be a retest fee charged upon your return to take the subsequent test. There is not a waiting period to retake basic control skills test(s).

Additional Requirements

All commercial vehicle drivers must:

- Be a California resident before applying for a California CLP/CDL.
- Disclose all states in which they were previously licensed during the past 10 years and surrender all out-of-state DLs (current or expired), if any.
- Certify that they do not have a DL from more than 1 state or country.
- Self-certify what type of commercial commerce you expect to operate.

- Notify their home state DMV of any conviction which occurred in other states within 30 days of the conviction.
- Notify their employer of any conviction within 30 days of the conviction using the Report of Out-of-State Traffic Conviction by a Commercial Driver (DL 535) form.
- Notify their employer of any revocation, suspension, cancellation, or disqualification before the end of the business day following the action.
- Give their employer a 10-year employment history of commercial driving, if applying for a job as a driver.

ENDORSEMENTS

A special endorsement is also required to drive the following types of vehicles. The endorsement shows as a single letter on the DL.

- **Placarded or marked vehicles transporting HazMat or wastes—(H).** Any driver, regardless of the vehicle Class (A, B, or C), who wants to haul any material that has been designated as hazardous under 49 *United States Code* (U.S.C.) §5103 and is required to be placarded under CFR, Title 49 §172 subpart F; or any quantity of a material listed as a select agent or toxin CFR, Title 42 §73 must add an “H” endorsement to their CDL. They must pass a special knowledge examination on how to recognize, handle, and transport HazMat.

NOTE: Applicants who apply for an original Class C CDL with the “H” endorsement are required to complete the skills test.

The Transportation Security Administration (TSA) and the U.S. Department of Transportation (DOT) require background checks on commercial drivers who are certified to transport HazMat. The background checks include a review of criminal, immigration, and FBI records. If the driver is found to represent a security threat, TSA will notify the person and the state will deny issuance of an endorsement.

- **Tank vehicles (including a cement truck)—(N).** Drivers of any CMV that is designed to transport any liquid or gaseous materials within a tank or tanks having an individual rated capacity of more than 119 gallons, and an aggregate rated capacity of 1,000 gallons or more that is either permanently or temporarily attached to the vehicle or the chassis must add a “N” endorsement

COMMERCIAL DRIVER LICENSING OFFICES

Call 1-800-777-0133 to schedule a CDL driving test at one of the following offices:

Arleta	Fremont	Mountain View	Stockton
Bakersfield	Fresno Commercial Driving Test Center	Rancho San Diego	Ukiah
Bishop		Redding	Ventura
El Centro	Gardena Commercial Driving Test Center	Salinas	W Sacramento Commercial Driving Test Center
Eureka		San Luis Obispo	
Fontana Commercial Driving Test Center	Lancaster	Santa Rosa	
	Modesto	Santa Teresa	Yuba City

For latest commercial driver licensing offices, go to dmv.ca.gov.

to their CLP/CDL. A CMV transporting an empty storage container tank, not designed for transportation, with a rated capacity of 1,000 gallons or more that is temporarily attached to a flat-bed trailer is not considered a tank vehicle. The endorsement applies to applicants who wish to drive a tank in Class A, B, or C CDL. Liquids in bulk cause driving control problems because the cargo is heavy, prone to shifting, and has a high center of gravity. These drivers must pass a special knowledge examination on the problems posed by large volume liquid cargos to add the endorsement to their CLP/CDL.

NOTE: Applicants applying for an original Class C CDL with the “N” endorsement are required to complete the skills test.

- **Passenger transport vehicles—(P).** Drivers who want to drive a vehicle having a design capacity to carry 10 or more people, including the driver, must add a “P” endorsement to their CLP/CDL. They must pass a special knowledge examination on safety considerations when transporting passengers and must pass skills tests in a passenger vehicle. The endorsement applies to applicants who want to drive a bus in any Class A, B, or C CDL.

NOTE: Applicants applying for a “P” endorsement are required to complete the skills test.

- **School bus—(S).** Drivers who want to drive a school bus must add an “S” endorsement to their CLP/CDL. They must pass a special knowledge

examination on safety considerations when transporting passengers in a school bus and must pass skills tests in a school bus. The endorsement applies to applicants who wish to drive a school bus in any Class A or B CDL.

- **Double/Triples combination—(T).** Many drivers who are qualified to drive Class A CDL may want to pull double or triple trailers. Research shows that considerable additional knowledge and skill is necessary to safely pull double and triple trailers in various traffic conditions and driving environments. Consequently, adding the “T” endorsement to drive a Class A CDL is necessary if wanting to pull double or triple trailers. The CDL holder must pass a special knowledge examination on the problems associated with pulling multiple trailers. **IMPORTANT:** Triple trailers are not legal in California.
- **Tank vehicles transporting hazardous materials or wastes—(X).** (Hazardous waste must meet the definition of CVC §§353 and 15278.) Drivers of tank vehicles who haul HazMat or waste in amounts requiring placards must add an “X” endorsement to their CDL to show that they passed the special knowledge examinations for both tank vehicles and HazMat.
- **Firefighter—(F).** Required for the operation of firefighting equipment. (Not required, but optional for Class A or B CDL holders.)

RESTRICTIONS

Restrictions may be added to a CLP/CDL based upon the type of vehicle and equipment that the driver uses for the skills test. There are 10 standardized restriction codes.

Note: If a CLP is issued with a “P” or “S” endorsement, it must also contain a Restriction P–No passenger in a CMV bus restriction.

If a CLP is issued with a “N” endorsement, it must also contain a Restriction X–No cargo in a CMV tank vehicle.

1. **(E)–No manual transmission:** If an applicant performs the skills test in a vehicle equipped with an automatic transmission, DMV must indicate on the CDL, if issued, that the person is restricted from operating a CMV equipped with a manual transmission. For the purpose of the skills test and restriction, an automatic transmission includes any transmission not operating fully on the gearshift and clutch principle.
2. **(K)–Intrastate only:** If an applicant certifies their status as either Non-Excepted Intrastate (NA) or Excepted Intrastate (EA), the state must indicate on the CDL, if issued, that the person is restricted from operating a CMV in Interstate commerce. States may impose this restriction for reasons other than those specified above.
3. **(L)–No Air brake equipped CMV:** If an applicant does not take or fails the air brake component of the knowledge test, or performs the skills test in a vehicle not equipped with air brakes, DMV must indicate on the CLP or CDL, if issued, that the person is restricted from operating a CMV equipped with any type of air brakes. For the purposes of the skills test and restriction, air brakes include any braking system operating fully or partially on the air brake principle.
4. **(M)–No Class A passenger vehicle:** If an applicant applying for a “P” endorsement performs the skills test in a passenger vehicle requiring a Class B CDL, DMV must indicate on the CDL, if issued, that the person is restricted from operating a passenger vehicle requiring a Class A CDL.
5. **(N)–No Class A and B passenger vehicle:** If an applicant applying for a “P” endorsement performs the skills test in a passenger vehicle requiring a Class C CDL, DMV must indicate on the CDL, if issued, that the person is restricted from operating a passenger vehicle requiring a Class A or B CDL.
6. **(O)–No tractor-trailer CMV:** If an applicant performs the skills test in a combination vehicle for a Class A CDL with the power unit and towed unit connected with a pintle hook or other non fifth-wheel connection, DMV must indicate on the CDL, if issued, that the person is restricted from operating a tractor-trailer combination connected by a fifth-wheel that requires a Class A CDL. An applicant who passes a skills test using a combination vehicle that is not a truck tractor semi-trailer combination, but is otherwise equipped with a fifth-wheel, will be issued a CDL with Restriction “O”.
7. **(P)–No passenger in CMV bus:** A CLP holder with a “P” endorsement is prohibited from operating a CMV carrying passengers, other than federal/state auditors and inspectors, test examiners, other trainees, and the CDL holder accompanying the CLP holder as prescribed by CFR, Title 49 §383.25(a)(1) of this part.
(S)–A CLP holder with an “S” endorsement is prohibited from operating a school bus with passengers, other than federal/state auditors and inspectors, test examiners, other trainees, and the CDL holder accompanying the CLP holder as prescribed by CFR, Title 49 §383.25(a)(1) of this part.
8. **(V)–Medical variance:** If DMV is notified according to CFR, Title 49 §383.73(o)(3) that the driver has been issued a medical variance, DMV must indicate the existence of such a medical variance on the Commercial Driver License Information System (CDLIS) driver record and the CDL document, if issued, using Restriction “V”.
9. **(X)–No cargo in CMV tank vehicle:** A CLP holder with an “N” endorsement may only operate an empty tank vehicle and is prohibited from operating any tank vehicle that previously contained HazMat that has not been purged of any residue.

- 10. (Z)—No full air brake equipped CMV:** If an applicant performs the skills test in a vehicle equipped with air over hydraulic brakes, DMV must indicate on the CDL, if issued, that the person is restricted from operating a CMV equipped with any braking system operating fully on the air brake principle. For the purposes of the skills test and restriction, air over hydraulic brakes includes any braking system operating partially on the air brake and partially on the hydraulic brake principle.

CDL EXCEPTIONS

Exceptions to the CDL requirements are:

- Drivers exempted under CHSC §25163.
- Drivers operating a vehicle in an emergency situation at the direction of a peace officer.
- Drivers who tow a fifth-wheel travel trailer over 15,000 pounds GVWR or a trailer coach over 10,000 pounds GVWR, when the towing is not for compensation. Drivers must have a noncommercial Class A DL.
- Drivers of housecars over 40 feet but not over 45 feet, with endorsement.
- Non-civilian military personnel drivers operating military vehicles.
- Implement of husbandry operators who are not required to have a DL.
- Vanpool drivers.

SPECIAL CERTIFICATES

Special certificates may sometimes be required in addition to a CDL, depending on the type of vehicle or load carried.

NOTE: It is unlawful to drive a school bus or transit vehicle while using a wireless (cell) telephone for non-work purposes. Emergency calls to law enforcement, a health care provider, fire department, or other emergency services are permitted.

Apply at DMV Field Offices for the Following Certificates:

Ambulance Driver Certificate—required for driving an ambulance used commercially in emergency service (CVC §2512). Persons who have an ambulance driver certificate must submit a copy of the Medical Examination Report (MER) form MSCA-5875 and Medical Examiner's Certificate (MEC) form MCSA-5876 to DMV every 2 years.

Hazardous Agricultural Materials (HAM) Certificate*—exempts persons who transport hazardous waste or placarded loads from CDL requirements if the:

- Person is at least 21 years of age.
- Person is employed in an agricultural operation.
- Load is not being transported for compensation.
- Vehicle is owned or leased by a farmer.
- Person has completed a HAM program approved by CHP. Although the person who qualifies for a HAM is not required to have a CDL, CMV penalties and sanctions will apply.
- Person submits a copy of the MER and MEC or Health Questionnaire (DL 546) form(s) to DMV every 2 years.
- Person operates a vehicle which is an implement of husbandry **or** requires a noncommercial Class C DL and does not exceed 50 miles from one point to another.

* Drivers subject to commercial driver sanctions.

Figure 1.1

Determining Class of CDL Required

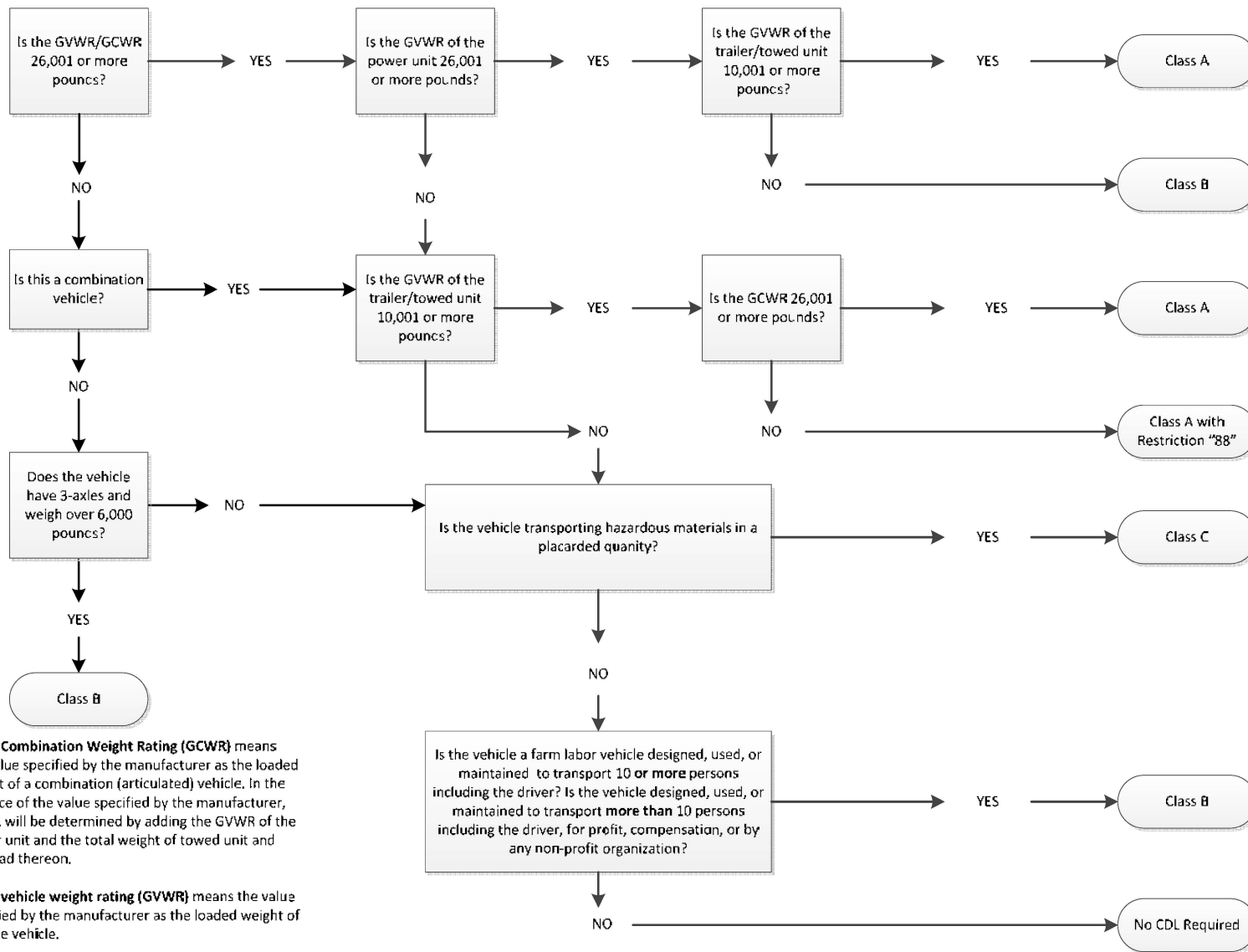

Verification of Transit Training (VTT) Document—requires drivers of transit bus vehicles to comply with specified training requirements. Transit bus vehicles provide the public with regularly scheduled transportation for which a fare is charged (does not include general public paratransit vehicles). Drivers who have a school bus driver certificate or school pupil activity bus certificate do not need a VTT.

Apply at CHP Offices for the Following Certificates:

General Public Paratransit Vehicle (GPPV) Certificate*—required for any person who drives:

- A vehicle which carries not more than 24 persons, including the driver, and provides local transportation to the general public (for example, Dial-A-Ride) (CVC §§336 and 12523.5).
- Pupils at or below the 12th grade level to or from a public or private school or school activity.
- Vehicles used in the exclusive transportation of disabled persons.

School Bus Driver Certificate*—required for any person who drives a bus for any school district or other party carrying public or private pupils (CVC §§545, 12517, 12522, 34500, and 34501.5). A school bus driver must also have an “S” endorsement on their CDL. School bus drivers 65 years of age and older must submit annual MER and MEC forms to DMV (CVC §12517.2).

School Pupil Activity Bus Certificate (SPAB)*—required for any person who drives a bus for any school district or other party carrying public or private pupils for school-related activities (CVC §§546 and 12517).

Farm Labor Vehicle Certificate*—required for any person who drives farm labor trucks and buses (CVC §§322 and 12519).

NOTE: The driver and all passengers in a farm labor vehicle are required to use seat belts.

Youth Bus Certificate*—required for any person who operates any bus, other than a school bus, which carries not more than 16 children and the driver to or from a school, to an organized non-school related activity, or to and from home (additional CHP training required) (CVC §§680 and 12523).

Tow Truck Driver Certificate*—required for drivers in emergency road service organizations that provide freeway service patrol operations pursuant to an agreement or who contract with a specified public transportation planning entity (traffic commission).

Vehicle for Developmentally Disabled Persons (VDDP)*—required for any person who operates a vehicle for a business or nonprofit organization or agency whose primary job is to transport for hire persons with developmental disabilities (*California Welfare and Institutions Code* §4512(A) and CVC §12523.6).

*Drivers subject to commercial driver sanctions.

GENERAL

To get a CDL, you must pass both the knowledge and skills tests. This handbook is designed to help you pass the tests. This handbook is not a substitute for a truck driver training class or program. Formal training is the most reliable way to learn the many special skills required for safely driving a large CMV and becoming a professional driver in the trucking industry. Figure 1.1 will help you determine if you need a CDL.

* Drivers subject to commercial driver sanctions.

1.1 – CDL TESTS

1.1.1 – Knowledge Tests

The commercial knowledge tests are available in English, Arabic, Chinese, Punjabi, Russian, and Spanish. All knowledge tests administered by DMV that are required to be taken by a CDL applicant or cardholder must be taken using the Automated Knowledge Testing equipment (AKTE).

You must take 1 or more knowledge tests, depending on what class of license and endorsements you need. If you are adding an endorsement, but not upgrading to a higher classification, DMV will waive all knowledge and endorsement tests completed or waived on the previous application, including HazMat, if the new application is started within 12 months of the previous renewal date or original CDL issue date. CDL knowledge tests include:

- The **general knowledge test**, required to be taken by all applicants.
- The **passenger transport test**, required to be taken by all bus driver applicants.
- The **air brakes test**, required to be taken by drivers of vehicles with air brakes, including air over hydraulic brakes.
- The **combination vehicles test**, required if you want to drive combination vehicles.
- The **hazardous materials test**, required if you want to haul hazardous materials as defined in CFR, Title 49 §383.5. To obtain this endorsement, you must pass a Transportation Security Administration (TSA) background check.
- The **tank vehicle test**, required if you want to haul any liquid or gaseous materials in a tank or tanks having an individual rated capacity of more than 119 gallons and an aggregate rated capacity of 1,000 gallons or more that is either permanently or temporarily attached to the vehicle or chassis.
- The **doubles/triples test**, required if you want to pull double or triple trailers. (Triple trailers are not legal in California.)
- The **school bus test**, required if you want to drive a school bus.
- The **firefighter endorsement test**, required to operate firefighting equipment. (Not required but optional for Class A or B CDL holders.)

NOTE: Allow for 2–3 hours if taking all tests. Your knowledge and/or endorsement test(s) will **not** be returned to you.

You may take the knowledge test at any DMV field office. Office hours vary. Visit dmv.ca.gov or call 1-800-777-0133 to make an appointment.

Use of Testing Aids Are Prohibited

The use of testing aids is strictly prohibited during the knowledge test. This includes, but is not limited to the *California Commercial Driver Handbook*, cheat sheets, or electronic communication devices such as a cell phone, hand-held computer, watch, etc.

If any testing aid(s) or a substitute test taker is used during the knowledge test, the knowledge test will be marked as a failure. An action may also be taken by DMV against your driving privilege or the driving privilege of anyone else who assists the applicant in the examination process.

During the vehicle inspection test, formerly known as pre-trip, DMV does not allow the use of testing aids, other than the vehicle inspection guide (Section 11) in this handbook. If you are caught using anything other than the inspection guide, the commercial skills test will be marked as a failure. The use of electronic devices, such as cell phones, blue tooth, CB radios, Apple watch, etc., is prohibited during the commercial skills test. In addition, people waiting in the testing vicinity are prohibited from using hand signals and shouting instructions. If this occurs, the test will be discontinued and marked as a commercial skills test failure. If markings are found on the vehicle being used for the test to help with passing the vehicle inspection or basic control skills test, formerly known as skills test, including but not limited to: writing on the vehicle, tape, paint markings that do not appear like they belong, or markings on the curbs, walls, or trees that would help the applicant maneuver the vehicle for the basic control skills test, the test will be discontinued and marked as a failure.

The use of any recording device, including a video event recorder (dash cam), is prohibited during any commercial skills test. A dash cam is a device that continuously records in a digital loop, recording audio and/or video, but saves audio and/or video only when triggered by an unusual motion or crash or when the vehicle is operated to monitor driver performance. If the vehicle is equipped with a recording device, it **must** be powered off or the visual and/or audio recording features **must** be disabled. If the recording device cannot

be powered off or disabled, which is typical for a CMV, the applicant **must** block the recording device, so there is no visual and/or audio recording during the road test.

1.1.2 – Skills Tests

If you pass the required knowledge test(s), you can take the CDL skills tests. There are 3 types of general skills tests that you are required to pass: vehicle inspection, basic control skills, and road test, formerly known as drive test. You must take these tests in the type of vehicle for which you wish to be licensed. Any vehicle that has components marked or labeled cannot be used for the vehicle inspection test. All skills tests must be conducted in English. An interpreter is prohibited for the CDL skills test.

Vehicle Inspection Test. You will be tested to see if you know whether your vehicle is safe to drive. You will be asked to do a vehicle inspection and explain to the examiner what you would inspect and why. This test takes approximately 40 minutes. If you do not pass the vehicle inspection test, the other tests will be postponed. There is no additional fee for retaking the vehicle inspection test on the same application. *See Section 11 for vehicle inspection test information.*

Basic Control Skills Test. You will be tested on your skill to control the vehicle. You will be asked to move your vehicle forward, backward, and turn it within a defined area. These areas may be marked with traffic lanes, cones, barriers, or something similar. The examiner will tell you how each control test is to be done. You will be scored on your ability to properly perform each exercise. This test takes approximately 30 minutes. Failure of any skills test ends the test. A retest fee is due for each basic control skills retest. *See Section 12 for skill test information.*

Road Test. You will be tested on your skill to safely drive your vehicle in a variety of traffic situations on a DMV specified route. The situations may include left and right turns, intersections, railroad crossings, curves, up and down grades, single or multi-lane roads, streets, or highways. The examiner will tell you where to drive. The test takes approximately 45–60 minutes. If you fail the road test, a retest fee is charged for each additional road test. *See Section 13 for road test information.*

A road test is **required**:

- For an original CDL.
- To remove a restriction placed on your CDL because of vehicle size or equipment.
- To add a “P” or “S” endorsement.
- To renew a CDL expired for more than 2 years.

CDL Restrictions

Your CDL will be restricted to the type of vehicle you use for the driving test. For example, if your test vehicle does not have air brakes, you will be restricted to driving vehicles without air brakes. If your passenger transport vehicle carries 15 persons or less including the driver, you will be restricted to driving a small size bus.

Troops to Trucks

The Troops to Trucks program allows DMV to waive the CDL skills test for qualified military service members who are employed, or were within the last year, in a military position requiring the operation of a military motor vehicle equivalent to a CMV on public roads and highways. Qualified applicants must submit completed CDL Certification for Military Waiver of CDL Driving Test (DL 963) **and** a Commanding Officer’s Certification of Driving Experience (DL 964) forms, in addition to any other documents required to apply for a CDL.

These forms are available at dmv.ca.gov. Active duty members will need to provide their military identification (ID), while veterans will need to provide a Certificate of Release or Discharge from Active Duty (DD Form 214), which shows their discharge was within the last year.

NOTE: The CDL skills test will not be waived for an “S” and/or “P” endorsement.

Figure 1.2 details which sections of this handbook you should study for each particular class of license and each endorsement.

WHAT SECTIONS SHOULD YOU STUDY?								
Sections to Study	License Type			Endorsement				
	Class A	Class B	Class C	Hazardous Materials	Double / Triple	Tank Vehicles	Passenger	School Bus
1	X	X	X					
2	X	X	X		X	X	X	
3	X	X	X					
4							X	
5*	X	X	X		X			
6	X				X	X		
7					X			
8						X		
9				X		X		
10								X
11	X	X	X				X	X
12	X	X	X				X	X
13	X	X	X				X	X

*Study Section 5 if you plan to operate vehicles equipped with air brakes.

Figure 1.2 – What to Study

1.2 – MEDICAL DOCUMENTATION REQUIREMENTS

CDL drivers in interstate commerce and drivers applying for, or who hold, a certificate to drive a School Bus, School Pupil Activity Bus, Youth Bus, General Public Paratransit Vehicle, or Farm Labor Vehicle must use medical examiners listed on the National Registry of Certified Medical Examiners (National Registry). The National Registry is a federal program establishing requirements for healthcare professionals that perform physical qualification examinations for CMV drivers. This program was developed to improve highway safety and driver health by requiring medical examiners to be trained and certified so they can determine effectively whether a commercial driver’s medical fitness for duty meets federal standards.

If you are required to have a CDL as part of your job, your employer shall pay the cost of the examination unless it was performed before you applied for the job *California Labor Code* (CLC §231).

A CDL driver may start an application and take the law and vision tests before submitting a medical report. **Do not issue** any commercial licensing document until the driver submits a qualifying medical report.

CDL drivers (interstate or intrastate) who successfully pass a commercial medical examination, will submit to DMV a valid (original or copy) MER and MEC form when applying for an original CLP or CDL or updating an existing medical expiration date. School bus drivers 65 years of age and older must submit a new medical report to DMV every year (CVC §12517.2(a)(b)).

MER and MEC forms completed by a U.S. licensed doctor of medicine (MD), doctor of osteopathy (DO), licensed physician assistant (PA), advanced practice registered nurse (APRN), or doctor of chiropractic (DC) who is listed on the National Registry of Certified Medical Examiners as clinically competent to perform the medical examination, must be given to DMV with your original application for a CLP or CDL. The MER and MEC forms must be dated within the last 2 years.

When submitting the MER, you are only required to submit pages 1–4. Page 5 of the MER form addresses meeting medical standards with a state variance. A DMV variance would exempt a driver from the

federal physical standards. **California does not have any variances or exemptions from the federal physical standards.**

The medical examiner **must** complete and sign the MEC form, for you to carry when you are driving commercially. You can be given a citation for driving out of class if you drive a CMV after your MEC expires.

Any noncommercial driver previously required to submit a Medical Examination Report (DL 51), ambulance drivers, van pool drivers, and Freeway Service Patrol tow truck drivers, are required to submit an MER and MEC form. **A DL 51 is no longer acceptable.**

A commercial driver who does **not** pass the medical examination **may** qualify for a California intrastate **restricted** Medical Certificate (DL 51B). These drivers **must** submit a MER to DMV showing they did not pass the medical examination in order to be considered for an intrastate restricted medical certificate.

You may take the completed MER and MEC form to a DMV field office to be updated. You may also mail the MER and MEC form, at least 4 weeks prior to the expiration of your previous medical to:

Department of Motor Vehicles
CDL Unit, MS G204
PO Box 944278
Sacramento, CA 94244-2780

1.2.1 – Interstate or Intrastate Commerce

CFR, Title 49 §383.71 requires CDL drivers to disclose the type of commercial operation they are engaged in:

Non-Excepted Interstate (NI): Operates or expects to operate a CMV in interstate commerce and subject to and meets the qualification requirements under CFR, Title 49 §391. The license does not restrict the transport, origination, or destination of the load to be transported.

- Interstate commerce means trade, traffic, or transportation in the U.S. that is between:
 - A place in a state and a place outside such state (including a place outside the U.S.).
 - Two places in the state through another state or a place outside of the U.S.
 - Two places in the state as part of trade, traffic, or transportation originating or terminating outside the state or U.S.

Non-Excepted Intrastate (NA): Operates or expects to operate in intrastate commerce and required to meet the qualification requirements under CFR, Title 49 §391. The cargo and passengers must originate and end in California. While driving commercially you may not cross state or international borders.

- Intrastate commerce means trade, traffic, or transportation in the U.S. that is:
 - Between two places in the state as part of trade, traffic, or transportation originating or terminating inside the state.

NOTE: If you self-certify as operating NA (Non-Excepted Intrastate) your CDL card and driver record will reflect a **CDL Intrastate Only Restriction (40/K)**.

Excepted Interstate (EI): California does not issue a CDL that is excepted from driver qualification requirements.

Excepted Intrastate (EA): California does not issue a CDL that is excepted from driver qualification requirements.

- Excepted and Non-Excepted Licensing
 - Some states issue a CDL that does not require drivers to meet the qualifications outlined in CFR, Title 49 §391. Those drivers are considered “excepted” drivers. California does not issue that kind of DL.
 - All drivers licensed by California to drive CMVs are non-excepted drivers.

IMPORTANT: You may be engaged in interstate commerce even if your vehicle does not leave the state. DMV strongly recommends a driver certify a driving type of non-excepted interstate (NI) if you meet the federal qualifications and there is any chance you might operate a CMV in interstate commerce.

1.3 – CDL DISQUALIFICATIONS

1.3.1 – General

You may not drive a CMV if you are disqualified for any reason.

1.3.2 – Alcohol, Leaving the Scene of an Accident, and Commission of a Felony

It is illegal to operate a CMV if your BAC is .04 percent or more. If you operate a CMV, you shall be deemed to have given your consent to alcohol testing.

You will lose your CDL for at least 1 year for a first offense for:

- Driving a CMV if your BAC is .04 percent or higher.
- Driving a CMV under the influence of alcohol.
- Refusing to undergo blood alcohol testing.
- Driving a CMV while under the influence of a controlled substance.
- Leaving the scene of an accident involving a CMV.
- Committing a felony involving the use of a CMV.
- Driving a CMV when the CDL is suspended/revoked.
- Causing a fatality through negligent operation of a CMV.

You will lose your CDL for at least 3 years if the offense occurs while you are operating a CMV that is placarded for HazMat.

You will lose your CDL for life for a second offense.

You will lose your CDL for life if you use a CMV to commit a felony involving controlled substances.

You will be put out of service for 24 hours if you have any detectable amount of alcohol under .04 percent.

1.3.3 – Serious Traffic Violations

Serious traffic violations are excessive speeding (15 miles per hour [mph] or more above the posted limit), reckless driving, improper or erratic lane changes, following a vehicle too closely, traffic offenses committed in a CMV in connection with fatal traffic accidents, driving a CMV without obtaining a CDL, or having a CDL in the driver's possession, and driving a CMV without the proper class of CDL and/or endorsements.

You will lose your CDL for at least:

- 60 days for 2 serious traffic violations within a 3 year period involving a CMV.
- 120 days for 3 or more serious traffic violations within a 3 year period involving a CMV.

1.3.4 – Violation of Out-of-Service Orders

You will lose your CDL for at least:

- 90 days for your first violation of an out-of-service order.
- 1 year if you have committed 2 violations of an out-of-service order in a 10 year period.
- 3 years for 3 or more violations of an out-of-service order in a 10 year period.

1.3.5 – Railroad-Highway Grade Crossing Violations

You will lose your CDL for at least:

- 60 days for your first violation.
- 120 days for your second violation within a 3 year period.
- 1 year for your third violation within a 3 year period.

These violations include violation of a federal, state, or local law, or regulation pertaining to one of the following 6 offenses at a railroad-highway grade crossing for:

- Drivers who are not required to always stop, failing to stop before reaching the crossing if the tracks are not clear.
- Drivers who are not required to always stop, failing to slow down and check that the tracks are clear of an approaching train.
- Drivers who are always required to stop, failing to stop before driving onto the crossing.
- All drivers, failing to have sufficient space to drive completely through the crossing without stopping.

- All drivers, failing to obey a traffic control device or the directions of an enforcement official at the crossing.
- All drivers, failing to negotiate a crossing because of insufficient undercarriage clearance.

1.3.6 – Hazardous Materials Endorsement Background Check and Disqualifications

If you require a HazMat endorsement, you will be required to submit your fingerprints and be subject to a background check.

You will be denied or will lose your HazMat endorsement if you:

- Are not a lawful permanent resident of the U.S.
- Renounce your U.S. citizenship.
- Are wanted or under indictment for certain felonies.
- Have a conviction in military or civilian court for certain felonies.
- Have been adjudicated as lacking mental capacity or involuntarily committed to a mental health facility as specified in CFR, Title 49 §1572.109.
- Are considered to pose a security threat as determined by the TSA.

For more information, visit universalenroll.dhs.gov or call 1-855-347-8371.

1.3.7 – Traffic Violations in Your Personal Vehicle

- The Motor Carrier Safety Improvement Act (MCSIA) of 1999 requires a CDL holder to be disqualified from operating a CMV if the CDL holder has been convicted of certain types of moving violations in their personal vehicle.
- If your privilege to operate your personal vehicle is revoked, cancelled, or suspended due to violations of traffic control laws (other than parking violations), you will also lose your CDL driving privileges.
- If your privilege to operate your personal vehicle is revoked, cancelled, or suspended due to alcohol, controlled substance, or felony violations, you will lose your CDL for 1 year. If you are convicted of a second violation in your personal vehicle or CMV, you will lose your CDL for life.
- If your license to operate your personal vehicle is revoked, cancelled, or suspended, you may not obtain a “hardship” license to operate a CMV.

1.3.8 – Violation Point Counts

Convictions that occur while you are driving a CMV or CDL holder are retained on your driving record as listed below:

- Major violations and disqualification actions, 55 years.
- Out-of-service violations and disqualification actions, 15 years.
- Accidents, serious violations, and disqualification actions, 10 years.
- Railroad grade crossings and disqualification actions, 4 years.
- Minor convictions, 3 years.

A traffic accident for driving unsafely counts as 1 point. Any accidents you contributed to or were responsible or at fault for, are normally counted as 1 point. If you are convicted of reckless driving, driving under the influence of alcohol and/or drugs, or hit-and-run, these violations count as 2 points.

You will lose your privilege to drive if you are considered a negligent operator of a CMV when your driving record shows the following point counts:

- 4 points in 12 months
- 6 points in 24 months
- 8 points in 36 months

You may be entitled to a higher point count (6, 8, or 10 points) if you request and appear for a hearing and if 4, 6, or 8 points were not obtained in a noncommercial Class C vehicle.

A violation received in a CMV carries 1½ times the point count. A Class A or B driver *who does not have a special certificate or endorsement* may be allowed 2 additional points before being considered a negligent operator.

Convictions reported by other states are added to your driving record and may result in CDL sanctions. If you have an out-of-state CDL, any conviction while operating in California will be reported to your home state.

NOTE: When a commercial driver is cited in a non-commercial vehicle, the driver *may* be eligible to attend traffic school (CVC §42005(c)).

1.3.9 – Violation of Hands-Free or Texting Law

Regardless of what type of vehicle you are in at the time of violation, you will lose your CDL for at least:

- 60 days for your second violation of the cell phone hands-free or texting law within a 3 year period and receive 1 point on your driving record.
- 120 days for your third and subsequent violations of the cell phone hands-free or texting law within a 3 year period and receive 1 point on your driving record.

1.4 – OTHER CDL RULES

Other federal and state rules affect drivers operating CMVs in all states. You must:

- Notify your motor vehicle licensing agency within 30 days if you are convicted in any other jurisdiction of any traffic violation (except parking). This is true no matter what type of vehicle you were driving.
- Notify your employer within 2 business days if your license is suspended, revoked, cancelled, or if you are disqualified from driving.
- No one can drive a CMV without a CDL. The court's action may involve a fine or require you to serve jail time for breaking this rule.
- If you have a HazMat endorsement, you must notify and surrender your HazMat endorsement to the state that issued your CDL within 24 hours of any conviction or indictment in any jurisdiction (civilian or military) in which you were found not guilty by reason of insanity of a disqualifying crime listed in CFR, Title 49 §1572.103, adjudicated as lacking mental capacity, involuntarily committed to a mental health facility as specified in CFR, Title 49 §1572.109, or you renounce your U.S. citizenship.
- Your employer may not let you drive a CMV if you have more than 1 license or your CDL is suspended or revoked. The court's action may involve a fine to the employer or require the employer to serve jail time for breaking this rule.
- All states are connected to one computerized system to share information about CDL drivers. The states will check drivers' history records to be sure that drivers do not have more than 1 CDL.

- You are not allowed to hold a mobile telephone to conduct a voice communication or dial a mobile telephone by pressing more than a single button when driving.
- You are not allowed to send or read text messages while driving.
- You must be properly restrained by a safety belt at all times while operating a CMV. The safety belt design holds the driver securely behind the wheel during an accident, helps the driver control the vehicle, and reduces the chance of serious injury or death. If you do not wear a safety belt, you are 4 times more likely to be fatally injured if you are thrown from the vehicle.

1.4.1 – State Laws and Rules

All CDL drivers must know the state laws limiting the size and weight of vehicles and loads. All CMVs must stop at locations posted for CHP testing and inspection (CVC §§2802–2805, and 2813).

Any officer, who has reason to believe a CMV is not safely loaded or the height, width, length, or weight of a vehicle and load is unlawful, is authorized to require the driver to stop and submit to an inspection, measurement, or weighing of the vehicle. The officer may have the driver stop in a suitable area and reload or remove any part of the load.

Any person driving a CMV over a highway or bridge illegally is liable for all damage caused to the highway or bridge. When the driver is not the owner of the vehicle but is operating it with the permission of the owner, the owner and driver may both have to pay for the damage.

A driver is disqualified from operating a Commercial Motor Vehicle (CMV) if convicted of any of the following offenses while operating either a COMMERCIAL or NONCOMMERCIAL motor vehicle (non-CMV):						
<i>Offense</i>	<i>1st conviction or DUI test refusal in CMV</i>	<i>1st conviction or DUI test refusal in non-CMV</i>	<i>1st conviction or DUI test refusal in CMV transporting Hazmat</i>	<i>2nd conviction or DUI test refusal in separate incident of any of these offenses in CMV</i>	<i>2nd conviction or DUI test refusal in separate incident of any of these offenses in non-CMV</i>	
Under the influence of alcohol	1 year	1 year	3 years	Life	Life	
Under the influence of controlled substance	1 year	1 year	3 years	Life	Life	
BAC of 0.04% or higher while operating CMV	1 year	Not applicable	3 years	Life	Not applicable	
Refusing to take DUI test required by implied consent laws	1 year	1 year	3 years	Life	Life	
Leaving the scene of an accident	1 year	1 year	3 years	Life	Life	
Using vehicle in felony not involving a controlled substance	1 year	1 year	3 years	Life	Life	
Driving CMV while DL is revoked, suspended, or canceled or when disqualified from operating a CMV	1 year	Not applicable	3 years	Life	Not applicable	
Negligent operation of CMV causing a fatality	1 year	Not applicable	3 years	Life	Not applicable	
Using vehicle in felony involving a controlled substance	Life	Life	Life	Life	Life	

Synopsis of Table 1 §383.51 Federal Motor Carrier Safety Administration

A driver is disqualified from operating a Commercial Motor Vehicle (CMV) if convicted of any of the following SERIOUS offenses:			
<i>Offense</i>	<i>2nd conviction in separate incident within 3 years of any of these offenses in a CMV</i>	<i>2nd conviction in separate incident within 3 years of any of these offenses in a non-CMV, if conviction results in revocation, cancellation, or suspension of all driving privileges</i>	<i>3rd or subsequent conviction in separate incident within 3 years of any of these offenses in a CMV</i>
Speeding 15 mph or more above the posted speed limit	60 days	60 days	120 days
Reckless driving	60 days	60 days	120 days
Making improper or erratic lane changes	60 days	60 days	120 days
Following too closely	60 days	60 days	120 days
Violating a traffic law which causes a fatal accident	60 days	60 days	120 days
Driving CMV without obtaining a CDL	60 days	60 days	120 days
Driving CMV without CDL in possession	60 days	Not Applicable	120 days
Driving CMV without proper class CDL and/or endorsements	60 days	Not Applicable	120 days
Synopsis Table 2 §383.51 Federal Motor Carrier Safety Administration			

A driver is disqualified from operating a Commercial Motor Vehicle (CMV) if convicted of any of the following SERIOUS offenses:

<i>Offense</i>	<i>2nd conviction in separate incident within 3 years of any of these offenses in a CMV</i>	<i>2nd conviction in separate incident within 3 years of any of these offenses in a non-CMV, if conviction results in revocation, cancellation, or suspension of all driving privileges</i>	<i>3rd or subsequent conviction in separate incident within 3 years of any of these offenses in a CMV</i>	<i>3rd or subsequent conviction in separate incident within 3 years of any of these offenses in a non-CMV, if conviction results in revocation, cancellation, or suspension of all driving privileges</i>
Speeding 15 mph or more above the posted speed limit	60 days	60 days	120 days	120 days
Reckless driving	60 days	60 days	120 days	120 days
Making improper or erratic lane changes	60 days	60 days	120 days	120 days
Following too closely	60 days	60 days	120 days	120 days
Violating a traffic law which causes a fatal accident	60 days	60 days	120 days	120 days
Driving CMV without obtaining a CDL	60 days	60 days	120 days	120 days
Driving CMV without CDL in possession	60 days	Not Applicable	120 days	Not Applicable
Driving CMV without proper class CDL and/or endorsements	60 days	Not Applicable	120 days	Not Applicable

Synopsis Table 2 §383.51 Federal Motor Carrier Safety Administration

A driver is disqualified from operating a Commercial Motor Vehicle (CMV) if convicted of any of the following RAILROAD HIGHWAY GRADE CROSSING offenses (either federal, state, or local):

<i>Offense</i>	<i>1st conviction</i>	<i>2nd conviction in separate incident within 3 years of any of these offenses</i>	<i>3rd or subsequent conviction in separate incident within 3 years of any of these offenses</i>
Fails to slow down to check for approaching train. NOTE: Regulations may not require the driver to stop.	No less than 60 days	No less than 120 days	No less than 1 year
Fails to stop before reaching the crossing if tracks are not clear. NOTE: Regulations may not require the driver to stop.	No less than 60 days	No less than 120 days	No less than 1 year
Fails to stop before crossing the tracks. NOTE: Regulations require the driver to stop.	No less than 60 days	No less than 120 days	No less than 1 year
Fails to allow enough space to completely cross the tracks without stopping.	No less than 60 days	No less than 120 days	No less than 1 year
Fails to obey traffic device or directions from a railroad crossing guard	No less than 60 days	No less than 120 days	No less than 1 year
Cannot cross tracks because of insufficient undercarriage clearance	No less than 60 days	No less than 120 days	No less than 1 year

Synopsis of Table 3 §383.51 Federal Motor Carrier Safety Administration

A driver is disqualified from operating a Commercial Motor Vehicle (CMV) if convicted of any of the following OUT-OF-SERVICE orders:

<i>Offense</i>	<i>1st conviction</i>	<i>2nd conviction in separate incident within 10 years of any of these offenses</i>	<i>3rd or subsequent conviction in separate incident within 10 years of any of these offenses</i>
Violates a driver or vehicle out-of-service order while transporting non-HazMat	No less than 90 days or more than 1 year	No less than 1 year or more than 5 years	No less than 3 years or more than 5 years
Violates a driver or vehicle out-of-service order while transporting HazMat or 16 or more passengers, including the driver.	No less than 180 days or more than 2 year	No less than 3 year or more than 5 years	No less than 3 years or more than 5 years

Synopsis of Table 4 §383.51 Federal Motor Carrier Safety Administration

State Air Emissions Rules

All commercial diesel vehicles and equipment that operate in California, even those based out-of-state or out-of-country, are subject to the emission requirements as specified by California Air Resources Board (CARB). To enforce these requirements, CARB is authorized to inspect all vehicles and equipment for excessive smoke, tampering, and compliance with fleet rules and issue citations with substantial penalties for non-compliance. Commercial diesel vehicle inspections are performed by CARB inspection teams at border crossings, CHP weigh stations, fleet facilities, and randomly selected roadside locations. Some key regulations are as follows:

- **Truck and Bus Regulation.** Be aware! **Beginning in 2020**, you will no longer be able to register vehicles with DMV that are not compliant with the truck and bus regulation. Regulation apply to nearly all privately and federally-owned diesel trucks and buses and privately and publicly-owned school buses with a GVWR greater than (>) 14,000 pounds. Since January 1, 2012, all diesel trucks and buses that operate in California must be upgraded with a diesel particulate filter (DPF) to reduce exhaust emissions. Since January 1, 2015, lighter and older heavier diesel trucks must be replaced with 2010 model year engines or equivalent. By **January 1, 2023**, nearly all trucks and buses will need to have 2010 model year engines or equivalent. The regulation provides a variety of flexibility options tailored to fleets operating low use vehicles and fleets operating in select locations like agricultural and construction areas.
- **Emission Control Label (ECL).** All diesel trucks and buses with a GVWR > 6,000 pounds that have a 1974 or newer engine must have an ECL on the engine. A properly affixed and legible manufacturer ECL is required as proof that the engine meets emission standards.
- **Periodic Smoke Inspection Program (PSIP).** All owners of California-based fleets with 2 or more on-road diesel trucks with a GVWR > 6000 pounds for engines 4 years old and older, must annually test the opacity of these vehicles and maintain test records for a minimum of 2 years. Starting in mid-2019, trucks equipped with a DPF, regardless of engine model year, must comply with a smoke opacity limit of 5 percent. Non DPF-equipped trucks will need to comply with smoke opacity limits of 20 percent, 30 percent, or 40 percent, depending on engine model year and technology.
- **Commercial Idling.** All commercial diesel vehicles with a GVWR > 10,001 pounds are limited to 5 minutes of non-essential idling in all areas of California. A CMV or school bus may not idle for any time at a school.
- **Tractor/Trailer Greenhouse Gas (GHG).** All 2011 through 2013 model-year sleeper/day-cab tractors must be SmartWay designated models. Model-year 2014 or newer tractors are covered by federal regulations. All 53 feet or longer box trailers must be SmartWay certified or aerodynamically retrofitted to meet minimum standards of operation.
- **Solid Waste Control Vehicle (SWCV).** All diesel trucks with a GVWR > 14,000 pounds and model-year engines from 1960 to 2006 used to collect residential and commercial solid waste must clean up the exhaust from these vehicles by using particulate matter (PM) reduction technology.
- **Public Agency and Utility Vehicles (PAU).** All diesel vehicles with a GVWR > 14,000 pounds and a 1960 through 2007 model year engine operated by a public agency or private utility must clean up the exhaust from these vehicles by using PM reduction technology.
- **Transit Bus.** All public transit agency fleet vehicles and urban buses with a GVWR > 8,500 pounds must add retrofit DPF filters, or upgrade to equipment that meets more stringent emission standards and/or replace existing diesel vehicles with alternative-fuel vehicles.

- **Transport Refrigeration Unit (TRU).** All diesel-fueled TRU trailers and TRU generator (gen) sets based in California must be registered with CARB, labeled with a CARB Identification Number (IDN), and meet in-use standards based upon the TRU engine model-year. Additionally, only compliant TRUs and gen sets may operate in California.
- **Port Truck (Drayage).** All on-road Class 7 and Class 8 (GVWR > 26,000 pounds) diesel trucks that transport cargo to and from California ports and intermodal rail yards, regardless of the state or country of origin, must be registered in CARB Drayage Truck Registry (DTR) and have a 2007 model-year or newer engine.

NOTE: For more information on each regulation above, visit arb.ca.gov/truckstop or call 866-6DIESEL (866-634-3735).

Length of Vehicle/Loads-Single Vehicle

The maximum length for a **single vehicle** is 40 feet. This length may be exceeded by parts complying with fender and mudguard provisions of the CVC.

NOTE: Some vehicles are conditionally exempted from the 40-foot maximum length (for example, semitrailers, buses, and housecars).

The front bumper of a vehicle must not extend more than 2 feet ahead of the fenders, cab, or radiator, whichever is foremost.

On a bus, a front and/or rear safety bumper may extend an additional foot, and a wheelchair lift may extend up to 18 inches ahead of the bus. Additional extensions up to 36 inches in front or 10 feet in the rear of some buses may be added to transport bicycles.

An articulated bus or trolley coach cannot exceed a length of 60 feet.

Length of Vehicle/Loads-Combination Vehicles

In a **combination of vehicles**, auxiliary parts or equipment, which do not provide space for carrying a load or are not used to support or carry the vehicle, may exceed the single vehicle length limit, but the combination may not exceed the length limit for combinations.

A semitrailer being towed by a motor truck or truck tractor may exceed 40 feet when certain conditions are met (CVC §35400(b)(4)).

A combination of a truck tractor and a trailer coupled together shall not exceed a total length of 65 feet except as provided in CVC §§35401 and 35401.5.

A combination of vehicles consisting of a truck tractor, semitrailer, and trailer cannot be longer than 75 feet, providing the length of either trailer does not exceed 28 feet 6 inches.

If posted, cities and counties may prohibit a combination of vehicles in excess of 60 feet in length on highways they control.

Other exceptions can be found in CVC §35401.5. Extension devices are allowed with restrictions (CVC §35402).

The **load** length on any vehicle or combination of vehicles may not be more than 75 feet in length measured from the front of the vehicle or load to the back of the vehicle or load.

Length Exceptions

Some length exceptions are listed below:

- If the load consists only of poles, timbers, pipes, integral structural materials, or single unit component parts, including: missile components, aircraft assemblies, drilling equipment, and tanks not exceeding 80 feet in length; provided they are being transported on one of the following:
 - Pole or pipe dolly or other legal trailer used as a pole or pipe dolly pulled by a motor vehicle.
 - Semitrailer.
 - Semitrailer and a pole or pipe dolly, pulled by a truck tractor to haul flexible, integral, structural material (CVC §35414).
- Public utilities. Refer to CVC §35414(B) for load exceptions.
- The load on any vehicle or combination of vehicles must not extend more than 3 feet beyond the foremost part of the front bumper or tires. There are exceptions for booms, masts of shovels and cranes, or water-well drilling and servicing equipment (CVC §35407). A load composed solely of vehicles may extend 4 feet ahead of the front tires or front bumper.
- The load on any single vehicle may not extend to the rear, beyond the last point of support, more than 2/3 of the length of the wheelbase of the vehicle. On a semitrailer, the wheelbase extends from the center of the last axle of the towing vehicle to the center of the last axle on the semitrailer.

Width of Vehicles and Loads

The outside width of the body of the vehicle or load must not exceed 102 inches (8½ feet). The width of a vehicle with pneumatic (air-filled) tires, measured from the outside of one wheel to the outside of the opposite wheel, must not exceed 108 inches (9 feet).

Permitted devices, limited to door handles, hinges, cable cinchers, chain binders, and placard holders may extend 3 inches (6 inches on one side for vehicles used for recreational purposes) on each side of the vehicle or load.

Required devices, limited to lights, mirrors, or other devices, may extend up to 10 inches on each side.

Cities and counties may post signs on highways they control, to permit wider vehicles, or prohibit vehicles wider than 96 inches (8 feet).

Special mobile equipment and special construction and highway maintenance equipment may not be more than 120 inches (10 feet) wide.

Motor coaches or buses may be 102 inches wide. When operated by common carriers for hire in urban or suburban service, they may be 104 inches wide.

When a vehicle is carrying loosely piled agricultural products, such as hay, straw, or leguminous plants in bulk, rather than crated, baled, boxed, or stacked, the load and racks that hold the load may be no more than 120 inches wide.

A special trip permit may be obtained from the California Department of Transportation (Caltrans) to transport trusses and similar one-piece construction components up to 12 feet wide (CVC §35780.5).

Variances for Farm Equipment

Implements of husbandry (farm equipment) are generally exempted from width and length limitations if they are operated, transported, or towed over a highway incidental to normal farming operations. Owners and operators of such equipment should refer to the CVC provisions which apply. A Caltrans transportation permit may be necessary (CVC §§36000 and 36600).

Heights of Vehicles and Loads

The vehicle height limit and/or load limit, measured from the surface of the roadway on which the vehicle stands, is 14 feet.

Exceptions:

- Double deck buses may not exceed 14 feet 3 inches.
- Farm equipment moved incidentally over a highway.

Weight Limits—General

Caltrans has authority to post signs at bridges and along state highways stating the maximum weight they will sustain. Such weight may be greater or lesser than the maximum weight limits for a vehicle specified in CVC §§35550–35557.

Counties and cities may post higher or lower weight limit signs along highways and bridges they control. Alternate routes may be given for vehicles that are too heavy for posted highways and bridges.

Note: Weight limitations by local ordinance do not prevent CMV from entering posted streets or highways by direct route to (a) make pickups or deliveries of goods, wares, and merchandise, (b) deliver materials for bona fide construction, repair, etc. of a structure for which a permit has been obtained, or (c) make public utility construction or repairs.

Axle Weight Limits

The gross weight that can be carried by the wheels of any one end of an axle must not exceed 20,000 pounds (20,500 pounds for buses). Additionally, the load limit stated by the tire manufacturer (molded on at least 1 sidewall) shall not be exceeded.

The weight carried by the wheel or wheels on any 1 axle must not exceed 10,500 pounds. This limitation does not apply to vehicles transporting livestock (CVC §35550).

Combinations of vehicles made up of a trailer or semitrailer, and each vehicle in the combination, must meet either the weight provisions of CVC §35551 or the following:

- The gross weight placed on a highway by the wheels on any one axle of a vehicle must not exceed 18,000 pounds. The gross weight on any 1 wheel, or wheels, supporting one end of an axle and resting on a roadway must not exceed 9,500 pounds.

EXCEPTIONS:

- The gross weight placed on a highway by the wheels on any front steering axle of a motor vehicle must not exceed 12,500 pounds.
- Vehicles carrying livestock are exempt from the gross weight limit, which applies to a wheel at one end of an axle.

A complete list of vehicles exempt from front axle weight limits can be found in CVC §35551.5(b).

The total gross weight with load, placed on a highway by any 2 or more consecutive axles of a combination of vehicles, or vehicle in the combination, where the distance between the first and last axles of the 2 or more consecutive axles is 18 feet or less, must not exceed that given for the respective distance as shown in the table in CVC §35551.5(c).

When the distance between the first and last axles is more than 18 feet, use the table shown in CVC §35551.5(d).

Weight Limit—Logs

Weight limits for vehicles transporting logs are contained in CVC §§35552 and 35785. Such additional weight may not be transported on interstate highways.

Weight-to-Axle Ratio (CVC §35551)

Highways and bridges are designed to carry only a certain amount of weight per foot of distance between axles. Vehicles carrying heavy loads must not put too much weight on any point; the limitations are shown in the tables found in CVC §§35551 and 35551.5.

The total gross weight in pounds placed on the highway by any group of 2 or more consecutive axles must not exceed that given for the respective distance in that table.

In addition to the weight specified in the previously mentioned table, 2 consecutive sets of tandem axles may carry a gross weight of 34,000 pounds each, if the distance between the first and last axles of the sets of axles is 36 feet or more. The gross weight on each set of tandem axles must not exceed 34,000 pounds and the gross weight on 2 consecutive sets of tandem axles must not exceed 68,000 pounds (CVC §35551(b)).

Loading/Unloading (CVC §35553)

Load limits are not enforced when vehicles are loading or unloading in the immediate vicinity of a loading or unloading area.

A driver moving a load under a special permit may not change the route. **EXCEPTION:** To avoid violating a local city traffic regulation, the driver may detour the route on nonresidential streets only and return to the route as soon as possible.

Penalties for Weight Restriction Violations

A driver who changes from the permitted route for an extralegal load, without a peace officer's authorization to do so, is guilty of a misdemeanor.

CHP Uniform Weight Standards

A standard for enforcing weight laws has been established by CHP. The standard states, "Vehicles weighing in excess of the legal limits by 100 pounds or more shall not be permitted to proceed until the overload has been adjusted or removed."

In practice, CHP will allow for a 200 pound *variation factor*. After applying the variation factor, any vehicle exceeding the axle weight, axle group weight, or gross weight limits by 100 pounds or more will be issued a citation and required either to adjust the load to make it legal or obtain an overweight permit before proceeding.

Cargo containing HazMat may be allowed to proceed as loaded, provided unloading or load adjustment cannot be handled with reasonable safety to the driver and the public.

Livestock and field-loaded bulk perishable agricultural products destined for human consumption being transported from the field to the first point of processing have a special exemption. Drivers of vehicles transporting livestock and perishable agricultural products will be cited and allowed to proceed as long as the weight does not exceed legal limits by 1,000 pounds on any axle or axle group of a single truck, or 2,000 pounds gross weight on a combination of vehicles.

Permits

Transporting an oversize extralegal load without a permit is punishable by a fine, jail time, or both. Excess load penalties may also be imposed.

It is against the law in California to drive or move, on any street or highway, any vehicle that is wider, higher, or heavier than the limits described here. Permits for oversized vehicles may be obtained from:

- Caltrans—for state highways.
- The city or county—for city or county highways.

Motor Carrier Permits

Any person who operates any CMV either for hire or privately (not for hire) must obtain a motor carrier permit (MCP) (CVC §34620).

The MCP definition for a CMV is any:

- Self-propelled vehicle listed in CVC §§34500(a), (b), (f), (g), and (k).
- Motor truck with 2 or more axles weighing more than 10,000 pounds GVWR.
- Other motor vehicle used to transport property for hire.

NOTE: An MCP CMV does not include vehicles operated by household goods carriers (*California Public Utilities Commission* (CPUC) §5109), pickup trucks (CVC §471), or 2-axle daily rental trucks (noncommercial use) weighing less than 26,001 pounds gross.

To obtain MCP forms and information, visit dmv.ca.gov, write, or call:

Department of Motor Vehicles
Motor Carrier Permit Operations, MS H875
PO Box 932370
Sacramento, CA 94232-3700
(916) 657-8153

Unified Carrier Registration (UCR)

Interstate or foreign motor carriers transporting property must obtain UCR, as outlined in the final regulations issued by the Federal Unified Carrier Registration Act of 2005. UCR fees can be paid online at ucr.in.gov.

To obtain UCR forms and information, visit dmv.ca.gov, write, or call:

Department of Motor Vehicles
Motor Carrier Permit Operations, MS H875
PO Box 932370
Sacramento, CA 94232-3700
(916) 657-8153

Speed Limits

The maximum speed limit in California is 55 mph for the following vehicles (CVC §22406):

- A truck or truck tractor having 3 or more axles.
- A vehicle pulling any other vehicle.
- A school bus transporting any pupil.
- A farm labor vehicle transporting passengers.
- A vehicle transporting explosives.
- A trailer bus.



For all other vehicles, the maximum speed limit on most California highways is 65 mph. However, for 2 lane undivided highways, the maximum speed limit is 55 mph, unless a higher speed limit is posted. On some highways, the maximum speed limit is 70 mph, but only if there are signs posted showing 70 mph.

No person shall drive at such a slow speed as to impede or block normal and reasonable movement of traffic, except when reduced speed is necessary for safe operation, compliance with the law, or when the size and weight of the vehicle or combination makes reduced speed unavoidable.

Right Lane Rule

Vehicles listed in CVC §22406 must be driven in the designated lane or lanes when signs are posted.

When no signs are posted, these vehicles must be driven in the right-hand traffic lane or as close as possible to the right edge or curb. On a divided highway with 4 or more traffic lanes in one direction, these vehicles may also be driven in the lane just to the left of the right-hand lane. When overtaking or passing another vehicle going in the same direction, drivers of such vehicles must use either: (1) the designated lane, (2) the lane just to the left of the right-hand lane, (3) the right-hand traffic lane when such use is permitted.

Designated System Access

Designated system access does not apply to a driver who is either: (1) preparing for a left or right-hand turn, (2) in the process of entering or exiting a highway, (3) driving in a lane other than the right-hand lane “to continue on the intended route.”

Buses, except school buses or trailer buses, may drive in any lane as long as they are not towing another vehicle.

Movement off or onto the designated system (freeways/highways) by larger trucks is allowed only at interchanges or exits, which have the following signs:



- Movement is allowed along signed routes to reach terminals. Terminals are locations where:
 - Freight is consolidated.
 - Full loads are off-loaded.
 - Vehicle combinations are regularly maintained, stored, or manufactured.

- Movement is allowed up to 1 mile from the identified exits or entrances leading to or from specified highways to obtain:

- Food
- Fuel
- Lodging
- Repairs



Slow Vehicle Rule

On a 2 lane highway where passing is unsafe, a slow-moving vehicle with 5 or more vehicles behind it must turn off the roadway at the nearest place designated by signs as a turnout, or wherever sufficient area for a safe turnout exists, to let the following vehicles pass.

Hours of Service

You are required to comply with California's driver hours of service regulations when you are involved in **INTRASTATE** commerce. You are considered to be involved in intrastate commerce when you do not:

- Cross the state line.
- Transport cargo which originated from another state.
- Transport cargo destined outside of California.
- Transport any hazardous substance or wastes (CFR, Title 49 §171.8).

Other Rules

You are required to comply with federal driver hours of service regulations when you are involved in **INTERSTATE** commerce. You are considered to be involved in interstate commerce when the cargo you transport:

- Originates out of state.
- Is destined out of state.
- Consists of hazardous substances or wastes (CFR, Title 49 §171.8).
- Any combination of the above.

Driver's Record of Duty Status

CHP is authorized to develop additional safety and driving regulations (CVC §§34501 and 34501.2).

A driver's record of duty status must be used to record all of the driver's hours. Drivers of CMVs must be in compliance with the hours of service requirements of CFR, Title 49 §395.8 and the *California Code of Regulations* (CCR), Title 13 §§1201–1213.

A driver's record of duty status must be kept in duplicate by each driver and each co-driver while driving, on duty but not driving, or resting in a sleeper berth. The record of duty status **must be presented for inspection immediately** upon request by any authorized CHP employee, any regularly employed and salaried police officer, or deputy sheriff. There may be instances when you do not need to maintain a record of duty status.

Accident Reporting

AS of January 1, 2017, every driver involved in an accident which results in death, injury, or property damage over \$1,000 must report the accident on a Report of Traffic Accident Occurring in California (SR 1) form to DMV. Report forms are available at **dmv.ca.gov**, by calling CHP at (916) 675-6677 or DMV at 1-800-777-0133, and at DMV offices.

You (or your authorized representative) must submit the report within 10 days of the accident, whether you caused the accident or not, and even if the accident occurred on private property. The SR 1 is required in addition to any other report made to or by law enforcement or your insurance company if the accident resulted in damage over \$1,000 and/or an injury or death. If you do not report the accident to DMV, your driving privilege will be suspended.

NOTE: CDL holders may downgrade to a noncommercial DL during any mandatory suspension period in order to be eligible to obtain a restricted DL. In order to regain your CDL, all knowledge, skills tests, and fees will be required.

California law states that you must notify your employer within 5 days if you have an accident while driving your employer's vehicle (CVC §16002). However, your employer may require you to notify them immediately.

Financial Responsibility (FR) Requirements

Motor Carriers of Property. Most CMVs transporting property are under the regulation of DMV, whose liability and property damage requirements are listed below. The following limits do not apply to pickup trucks as defined in CVC §471 and 2-axle daily rental trucks with a GVWR less than 26,001 pounds when operated in noncommercial use:

- Transporting general freight exclusively in vehicles having a GVWR of 10,000 pounds or less: \$300,000 combined single limit.
- Transporting general freight in vehicles having a GVWR of 10,001 pounds or more: \$750,000 combined single limit.
- Transporting petroleum products in bulk on the highways: \$500,000 for injury or death of 1 person, \$1,000,000 for injury or death to 2 or more

persons, \$200,000 for damage to property, or \$1,200,000 combined single limit.

- Transporting oil, HazMat, or waste: \$1,000,000 combined single limit.
- Transporting hazardous substances, compressed gas, liquefied compressed gas in cargo tanks, portable tanks, or hopper-type vehicles with capacities in excess of 3,500 water gallons, or transporting Division 1.1, 1.2, or 1.3 explosives, poison gas, or highway-route controlled quantities of radioactive materials: \$5,000,000 combined single limit.

Information on transporting HazMat or wastes may be obtained from the Department of Toxic Substances Control (DTSC) and CHP.

HOURS OF SERVICE

Condition	FEDERAL (Interstate commerce)	CALIFORNIA (Intrastate commerce)
Driving time	You may not drive for more than 11 hours following 10 consecutive hours off duty.	You may not drive for more than 12 hours following 10 consecutive hours off duty.
On duty time	You may not drive beyond the 14th hour after coming on duty following 10 hours off duty. You may perform work, except for driving, after being on duty for 14 hours.	You may not drive after having been on duty for 16 hours. You may perform work, except for driving, after being on duty for 16 hours.
Multiple day on duty time limitations	You are not eligible to drive after having been on duty for 60 hours in a 7-day period. However, if a motor carrier has commercial motor vehicles operating 7 days a week, the driver is not eligible to drive after having been on duty for 70 hours in an 8-day period. A driver may restart a 7/8 consecutive day period after taking 34 or more consecutive hours off duty.	You are not eligible to drive after having been on duty for 80 hours in any 8 consecutive day period or if transporting farm products after having been on duty 112 hours in any consecutive 8-day period. For truck drivers, any period of 8 consecutive days may end with the beginning of any off-duty period of 34 or more consecutive hours.
Off duty time	After driving for 11 hours or being on duty for 14 hours, you may not drive again until you have had 10 consecutive hours off duty. Exception: If the truck is equipped with a sleeper berth, these 10 hours may be broken up into 2 periods provided one is not less than 8 hours.	After driving for 12 hours or being on duty for 16 hours, you may not drive again until you have had 10 consecutive hours off duty. Exception: If the truck is equipped with a sleeper berth, these 10 hours may be broken up into 2 periods, provided one period is not less than 8 hours.
Adverse driving condition	You may drive an additional 2 hours if you encounter adverse weather conditions which were not apparent at the start of the trip.	You may drive an additional 2 hours if you encounter adverse weather conditions which were not apparent at the start of the trip. Regardless of the adverse conditions, you are not allowed to drive for more than 14 hours or after having been on duty more than 16 hours.

NOTE: The changes to hours of service (HOS) rules do not affect bus drivers, at this time. For up-to-date HOS rules, visit fmcsa.dot.gov or chp.ca.gov.

NOTE: Not all coverage requirements are listed in this section. For questions related to liability insurance for motor carriers, call the DMV Motor Carrier Permit Operations at (916) 657-8153.

FR may be maintained by one of the following:

- Certificate of Insurance (MC 65 M).
- Surety bond (MC 55 M).
- Certificate of Self Insurance Motor Carriers of Property (MC 131 M).

Motor carriers must maintain evidence of insurance on file during the active life of the permit. Whenever DMV determines that a motor carrier's Certificate of Insurance or surety bond has expired or been cancelled, DMV will suspend the MCP. To avoid MCP suspension, contact your insurance provider to submit valid liability coverage.

Proof of FR

Drivers must show evidence of FR prior to operation of the vehicle. Evidence is met if the vehicle displays exempt plates or is owned, leased, or under the direction of the U.S. government.

1.5 – INTERNATIONAL REGISTRATION PLAN AND INTERNATIONAL FUEL TAX AGREEMENT

If you operate a CDL required vehicle in interstate commerce, the vehicle, with few exceptions, is required to be registered under the International Registration Plan (IRP) and International Fuel Tax Agreement (IFTA). These federally mandated programs provide for the equitable collection and distribution of vehicle license fees and motor fuel taxes for vehicles traveling throughout the 48 contiguous U.S. and 10 Canadian provinces.

Under the IRP, jurisdictions must register apportioned vehicles, which includes issuing license plates and cab cards or proper credentials, calculating, collecting, and distributing IRP fees, auditing carriers for accuracy of reported distance and fees, and enforcing IRP requirements.

Registrant responsibilities under the plan include applying for IRP registration with base jurisdiction, providing proper documentation for registration, paying appropriate IRP registration fees, properly displaying registration credentials, maintaining accurate distance records, and making records available for jurisdiction review.

The basic concept behind IFTA is to allow a licensee (motor carrier) to license in a base jurisdiction for the reporting and payment of motor fuel use taxes.

Under IFTA, a licensee is issued one set of credentials, which authorizes operations through all IFTA member jurisdictions. The motor fuel use taxes collected pursuant to IFTA are calculated based on number of miles (or kilometers) traveled and the number of gallons (liters) consumed in the member jurisdictions. The licensee files one quarterly tax return with the base jurisdiction by which the licensee will report all operations through IFTA member jurisdictions.

It is the base jurisdiction's responsibility to remit the taxes collected to other member jurisdictions and represent the other member jurisdictions in the tax collection process, including the performance of audits.

An IFTA licensee must retain records to support the information reported on the IFTA quarterly tax return.

The IRP registrant and IFTA licensee may be the vehicle owner or operator.

The requirement for acquiring IRP license plates for a vehicle and IFTA license for a motor carrier is determined by the definitions from the IRP and IFTA for apportionable vehicle and qualified motor vehicle.

For the Purposes of IRP:

Apportionable vehicle means (except as provided below) any power unit that is used, or intended for use, in two or more member jurisdictions for the transportation of persons for hire, or designed, used, or maintained primarily for the transportation of property, and at least one of the following:

- Has 2 axles and a gross vehicle weight (GVW) or registered GVW in excess of 26,000 pounds (11,793.401 kilograms).
- Has 3 or more axles, regardless of weight.
- Used in combination, when the GVW of such combination exceeds 26,000 pounds (11,793.401 kilograms).

A recreational vehicle, vehicle displaying restricted plates, bus used in the transportation of chartered parties, or government-owned vehicle is not an apportionable vehicle; except that a truck or truck tractor, power unit in a combination of vehicles having a GVW of 26,000 pounds (11,793.401 kilograms) or less, and bus used in the transportation of chartered parties, may be registered under IRP at the option of the registrant.

While similar, the “qualified motor vehicle” in IFTA means a motor vehicle used, designed, or maintained for transportation of persons or property and at least one of the following:

- Has 2 axles and a GVW or registered GVW exceeding 26,000 pounds (11,797 kilograms).
- Used in combination, when the weight of such combination exceeds 26,000 pounds (11,797 kilograms) GVW or registered GVW. Qualified motor vehicle does not include recreational vehicles.
- Has 3 or more axles, regardless of weight.

- If the vehicle you operate is registered under IRP and you are motor carrier licensed under IFTA, you are required to comply with the mandatory record keeping requirements for operating the vehicle. A universally accepted method of capturing this information is through the completion of an Individual Vehicle Distance Record (IVDR), sometimes referred to as a Driver Trip Report. This document reflects the distance traveled and fuel purchased for a vehicle that operates interstate under apportioned IRP registration and IFTA fuel tax credentials.

Although the actual format of the IVDR may vary, the information that is required for proper record keeping does not.

In order to satisfy the requirements for IVDRs, these documents must include the following information:

Distance

Per Article IV of the IRP:

- (i.) Date of trip (starting and ending).
- (ii.) Trip origin and destination city and state or province.
- (iii.) Route(s) of travel.
- (iv.) Beginning and ending odometer or hub odometer reading of the trip.
- (v.) Total distance traveled.
- (vi.) In-jurisdiction distance.
- (vii.) Power unit number or vehicle identification number.

Fuel

Per Section P560 of the *IFTA Procedures Manual*:

- .300 An acceptable receipt or invoice must include, but shall not be limited to, the following:
- .005 Date of purchase.
- .010 Seller’s name and address.
- .015 Number of gallons or liters purchased.
- .020 Fuel type.
- .025 Price per gallon, or liter, or total amount of sale.
- .030 Unit number or other unique vehicle identifier.
- .035 Purchaser’s name.

An example of an IVDR completed in entirety for each trip can be found in **Figure 1**. An individual IVDR is filled out for each vehicle. The rules to follow when determining how and when to log an odometer reading are the following:

- At the beginning of the day.
- When leaving the state or province.
- At the end of the trip/day.

Not only do the trips need to be logged, but the fuel purchases need to be documented as well. You must obtain a receipt for all fueling and include it with your completed IVDR.

Make sure that all trips that you enter are always filled out in descending order and that your trips include all state/provinces that you traveled through on your route.

There are different routes that a driver may take, and most of the miles may be within one state or province. Whether or not the distance you travel is primarily in one jurisdiction or spread among several jurisdictions, all information for the trip must be recorded. This includes the dates, routes, odometer readings, and fuel purchases.

By completing the IVDR in full and keeping all records required by both the IRP and IFTA, you will ensure that you and your company are in compliance with all state and provincial laws surrounding fuel and distance record keeping requirements.

The IVDR serves as the source document for the calculation of fees and taxes that are payable to the jurisdictions in which the vehicle is operated, so these original records must be maintained for a minimum of 4 years.

In addition, these records are subject to audit by the taxing jurisdictions. Failure to maintain complete and accurate records could result in fines, penalties, and suspension or revocation of IRP registrations and IFTA licenses.

For additional information on IRP and requirements related to IRP, contact your base jurisdiction motor vehicle department or IRP, Inc. (official repository for the IRP) by visiting IRP, Inc. at irponline.org. There is a record keeping video on the website home page available in English, Spanish, and French. For additional information on IFTA and requirements related to IFTA, contact the appropriate agency in your base jurisdiction. You will also find useful information about the agreement at the official repository of IFTA at iftach.org/index.php.

Carrier	ABC Carriers Inc.		Account Number	99999999		Driver Name	John Doe Jr.		Unit Number	58		
Lead Information	1/2/04 Pick Up Maplewood MO Origins: 1/3/04 Pick Up Springfield IL			Destinations: 1/2/04 Delivery Springfield IL 1/03/04 Delivery Dayton OH			Other Comments					
Date	Town Origin-Jurisdiction Lines-Town Destination	State	Ending Odometer	Miles by Jurisdiction	Highways or Routes Traveled	Name of Fuel Stop and Location	Gallons Purchased					
1/2/2004	Beginning State & Odometer Reading	MO	45,869	All other odometer reading will be ending readings.								
	Maplewood MO - IL Line	MO	45,878	9	94							
	MO Line - Springfield IL	IL	45,976	98	55-29	Ted's I-72 Fuel -- Springfield IL	98					
1/3/2004	Springfield IL - IN Line	IL	46,101	125	29-97-72-57-74							
	IN Line - OH Line	IN	46,259	158	74-32-65-465-70							
	OH Line - Dayton OH	OH	46,297	38	70-49							
Total Trip Miles **				428	Total Fuel Purchases							98
Odometer Miles, Total Trip Miles & Total Jurisdictional Miles Must Agree			Total Jurisdictional Miles **									
			Jurisdiction	Miles	Jurisdiction	Miles						
			MO	9								
			IL	223								
			IN	158								
			OH	38								
Ending Odometer			46,297	OFFICE USE ONLY								
Beginning Odometer			45,869									
Total Odometer Miles **			428									
<p>Note: Beginning odometer reading on this trip must match ending reading from prior trip and ending reading from this trip must be the beginning reading on the next trip.</p>												

Figure 1
Individual Vehicle Mileage and Fuel Record (Example)

SECTION 2: DRIVING SAFELY

THIS SECTION COVERS

- 2.1 – Vehicle Inspection
- 2.2 – Basic Control of Your Vehicle
- 2.3 – Shifting Gears
- 2.4 – Seeing
- 2.5 – Communicating
- 2.6 – Controlling Your Speed
- 2.7 – Managing Space
- 2.8 – Seeing Hazards
- 2.9 – Distracted Driving
- 2.10 – Aggressive Drivers/Road Rage
- 2.11 – Driving at Night
- 2.12 – Driving in Fog
- 2.13 – Driving in Winter
- 2.14 – Driving in Very Hot Weather
- 2.15 – Railroad-Highway Crossings
- 2.16 – Mountain Driving
- 2.17 – Driving Emergencies
- 2.18 – Anti-lock Braking Systems (ABS)
- 2.19 – Skid Control and Recovery
- 2.20 – Accident Procedures
- 2.21 – Fires
- 2.22 – Alcohol, Other Drugs, and Driving
- 2.23 – Hazardous Materials Rules for All Commercial Drivers

This section contains knowledge and safe driving information that all CDL holders should know. You must pass a test on this information to get a CDL. This section does not have specific information on air brakes, combination vehicles, doubles, or passenger vehicles. When preparing for the vehicle inspection test, you must review the material in Section 11 in addition to the information in this section. This section does have basic information on HazMat that all drivers should know. If you need an “H” endorsement, study Section 9.

2.1 – VEHICLE INSPECTION

2.1.1 – Why Inspect

Safety is the most important reason you inspect your vehicle, safety for yourself and other road users.

A vehicle defect found during an inspection could save you problems later. You could have a breakdown on the road that will cost time and dollars, or even worse, an accident caused by the defect.

Federal and state laws require that drivers inspect their vehicles. Federal and state inspectors may also inspect your vehicles. If they judge the vehicle to be unsafe, they will put it “out-of-service” until it is fixed.

2.1.2 – Types of Vehicle Inspections

Vehicle Inspection

A vehicle inspection will help you find problems that could cause an accident or breakdown. Vehicle inspections should be done routinely **before** operating the vehicle. Review the last vehicle inspection report. Make sure the vehicle has been released for service by the maintenance mechanics, if applicable. The motor carrier must repair any items in the report that affect safety, and certify on the report that repairs were made or were unnecessary. Remember, when you get behind the wheel, you (not the mechanic) are responsible for the safe operation of the vehicle. If the defects have been repaired, sign the previous driver’s report. There is detailed information on vehicle inspections in Section 11 of this handbook.

Trip Inspection

For safety during a trip, you should:

- Watch gauges for signs of trouble.
- Use your senses to check for problems (look, listen, smell, and feel).

Check these critical items when you stop:

- Tires, wheels, and rims.
- Brakes.
- Lights and reflectors.
- Brake and electrical connections to trailer.
- Trailer coupling devices.
- Cargo securement devices.

After-Trip Inspection and Report

You should do an after-trip inspection at the end of the trip, day, or tour of duty on each vehicle you operated. It may include filling out a vehicle condition report listing any problems you find. The inspection report helps a motor carrier know when the vehicle needs repairs.

2.1.3 – What to Look For

Tire Problems

- Too much or little air pressure.
- Bad wear. You need at least 4/32 inch tread depth in every major groove on front tires. You need 2/32 inch on other tires. No fabric should show through the tread or sidewall.
- Cuts or other damage.
- Tread separation.
- Dual tires that come in contact with each other or parts of the vehicle.
- Mismatched sizes.
- Radial and bias-ply tires used together.
- Cut or cracked valve stems.
- Regrooved, recapped, or retreaded tires on the front wheels of a bus. These are prohibited.

Wheel and Rim Problems

- Damaged rims.
- Rust around wheel nuts may mean the nuts are loose (check tightness). After a tire has been changed, stop a short while later and recheck tightness of nuts.
- Missing clamps, spacers, studs, or lugs mean danger.
- Mismatched, bent, or cracked lock rings are dangerous.
- Wheels or rims that have had welding repairs are not safe.

Bad Brake Drums or Shoes

- Cracked drums.
- Shoes or pads with oil, grease, or brake fluid on them.
- Shoes worn dangerously thin, missing, or broken.

Steering System Defects

- Missing nuts, bolts, cotter keys, or other parts.
- Bent, loose, or broken parts, such as steering column, steering gear box, or tie rods.
- If power steering equipped, check hoses, pumps, fluid level, and for leaks.
- Steering wheel play of more than 10 degrees (approximately 2 inches movement at the rim of a 20 inch steering wheel) can make it hard to steer.

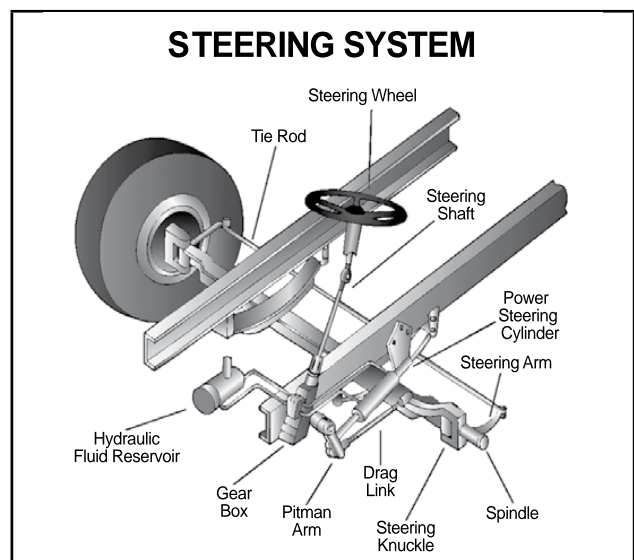

Figure 2.1

Suspension System Defects

The suspension system holds up the vehicle and its load and keeps the axles in place. Therefore, broken suspension parts can be extremely dangerous. Look for:

- Spring hangers that allow movement of an axle from its proper position. See Figure 2.2.

Cracked or Broken Spring Hangers

- Missing or broken leaves in any leaf spring. If 1/4 or more are missing, it will put the vehicle “out-of-service,” but any defect could be dangerous. See Figure 2.3.
- Broken leaves in a multi-leaf spring or leaves that have shifted so they might hit a tire or other part.
- Leaking shock absorbers.
- Torque rods or arms, u-bolts, spring hangers, or other axle positioning parts that are cracked, damaged, or missing.
- Air suspension systems that are damaged and/or leaking. See Figure 2.4.
- Any loose, cracked, broken, or missing frame members.

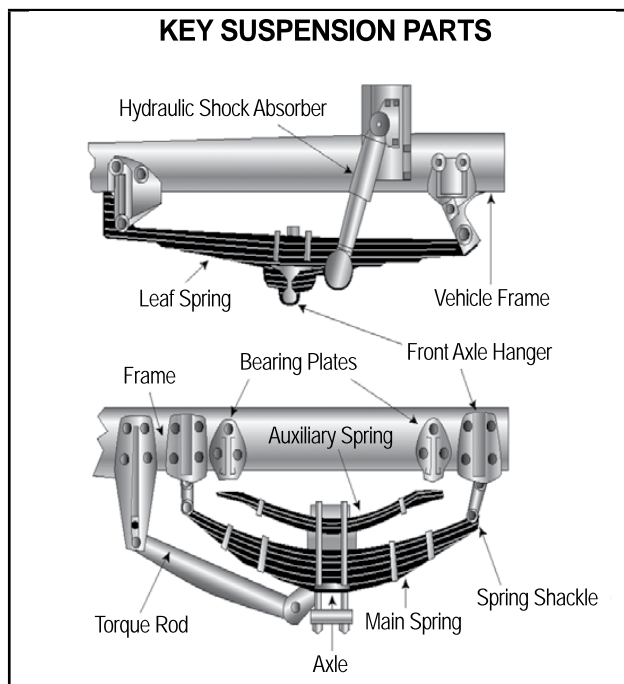

Figure 2.2

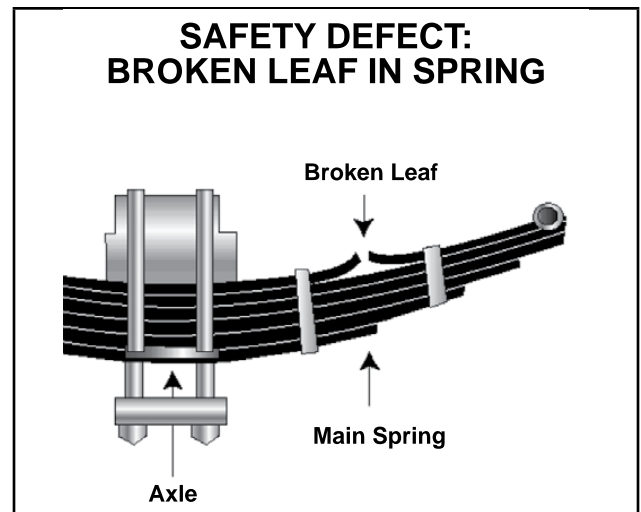

Figure 2.3

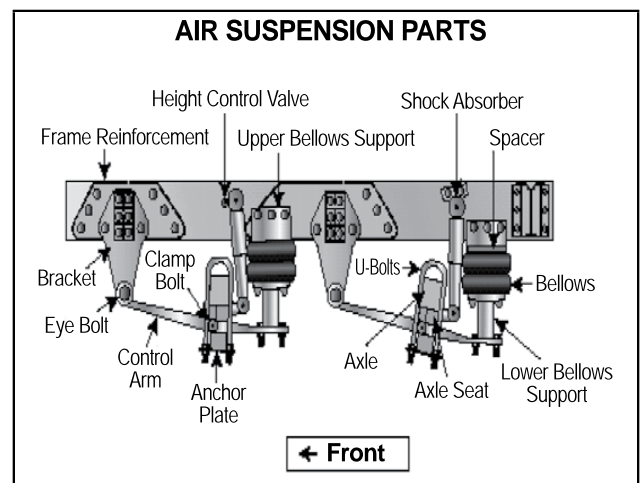

Figure 2.4

Exhaust System Defects

A broken exhaust system can let poison fumes into the cab or sleeper berth. Look for:

- Loose, broken, or missing exhaust pipes, mufflers, tailpipes, or vertical stacks.
- Loose, broken, or missing mounting brackets, clamps, bolts, or nuts.
- Exhaust system parts rubbing against fuel system parts, tires, or other moving parts of the vehicle.
- Exhaust system parts that are leaking.

Emergency Equipment

Vehicles must be equipped with emergency equipment. Look for:

- Fire extinguisher(s).
- Spare electrical fuses (unless equipped with circuit breakers).
- Warning devices for parked vehicles (for example, 3 red reflective warning triangles, 6 fuses, or 3 liquid burning flares).

2.1.4 – CDL Vehicle Inspection Test

To obtain a CDL, you will be required to pass a vehicle inspection test. You will be tested to see if you know whether your vehicle is safe to drive. You will be asked to do an inspection of your vehicle. You must point to or touch and name the item you are inspecting and explain why to the examiner. The following 7-step inspection method should be useful.

Cargo (Trucks). You must make sure the truck is not overloaded and the cargo is balanced and secured before each trip. If the cargo contains HazMat, you must inspect for proper papers and placarding.

2.1.5 – 7-Step Inspection Method

Method of Inspection. Do a vehicle inspection the same way each time so you will learn all the steps and be less likely to forget something.

Approaching the Vehicle. Notice the general condition. Look for damage or the vehicle leaning to one side. Look under the vehicle for fresh oil, coolant, grease, or fuel leaks. Check the area around the vehicle for hazards to vehicle movement (people, other vehicles, objects, low-hanging wires, limbs, etc.).

Vehicle Inspection Guide

Step 1: Vehicle Overview

Review Last Vehicle Inspection Report. Drivers may have to make a vehicle inspection report in writing each day. The motor carrier must repair any items in the report that affect safety and certify on the report that repairs were made or were unnecessary. You must sign the report only if defects were noted and certified to be repaired or repairs are not needed.

Step 2: Check the Engine Compartment

Check that the parking brakes are on and/or wheels chocked. You may have to raise the hood, tilt the cab (secure loose things so they do not fall and break something), or open the engine compartment door. Check the following:

- Engine oil level.
- Coolant level in radiator and condition of hoses.
- Power steering fluid level and condition of hose (if so equipped).
- Windshield washer fluid level.
- Battery fluid level, connections and tie downs (battery may be located elsewhere).
- Automatic transmission fluid level (may require engine to be running).
- Check belts for tightness and excessive wear (alternator, water pump, air compressor). Know how much “give” the belts should have when adjusted right, and check each one.
- Engine compartment for leaks (fuel, coolant, oil, power steering fluid, hydraulic fluid, battery fluid).
- Electrical wiring insulation for cracks and wear.

Lower and secure the hood, cab, or engine compartment door.

Step 3: Start the Engine and Inspect Inside of the Cab

Get in and Start the Engine

- Make sure the parking brake is on.
- Put the gearshift in Neutral (or “Park” if automatic).
- Start engine and listen for unusual noises.
- If equipped, check the anti-lock braking system (ABS) indicator lights. The light on the dash should come on and then turn off. If it stays on, the ABS is not working properly. For trailers only, if the yellow light on the left rear of the trailer stays on, the ABS is not working properly.

Look at the Gauges

- **Oil pressure.** Pressure should come up to normal within seconds after the engine is started. See Figure 2.5.

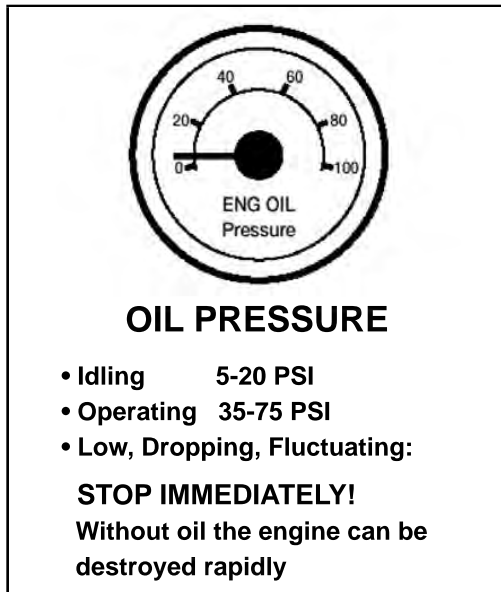

Figure 2.5

- **Air pressure.** Pressure should build from 50–90 pounds per square inch (psi) within 3 minutes. Build the air pressure to governor cut-out (usually around 120–140 psi.) **Know your vehicle's requirements.**
- **Ammeter and/or voltmeter.** Should be in normal range(s).
- **Coolant temperature.** Should begin gradual rise to normal operating range.
- **Engine oil temperature.** Should begin gradual rise to normal operating range.
- **Warning lights and buzzers.** Oil, coolant, charging circuit warning, and ABS lights should go out right away.

Check the Condition of the Controls

Check all of the following for looseness, sticking, damage, or improper setting:

- Steering wheel.
- Clutch.
- Accelerator (gas pedal).
- Brake controls:
 - Foot brake.
 - Trailer brake (if the vehicle has one).
 - Parking brake.
 - Retarder controls (if the vehicle has them).
- Transmission controls.
- Inter-axle differential lock (if the vehicle has one).
- Horn(s).
- Windshield wiper/washer.
- Lights.
 - Headlights.
 - Dimmer switch.
 - Turn signal.
 - 4-way emergency flashers.
 - Parking, clearance, identification, marker switch(es).

Check Mirrors and Windshield

Inspect mirrors and windshield for cracks, dirt, illegal stickers, or other obstructions to seeing clearly. Clean and adjust as necessary.

Check the Emergency Equipment

Check for safety equipment:

- Spare electrical fuses (unless the vehicle has circuit breakers).
- 3 red reflective triangles, 6 fuses, or 3 liquid burning flares.
- Properly charged and rated fire extinguisher.

Check for optional items, such as:

- Chains (where winter conditions require them).
- Tire changing equipment.
- List of emergency phone numbers.
- Accident reporting kit (packet).

Check the Safety Belt

Check that the safety belt is securely mounted, adjusts, and latches properly, and is not ripped or frayed.

Step 4: Turn off the Engine and Check the Lights

Make sure the parking brake is set, turn off the engine, and take the key with you. Turn on the headlights (low beams) and 4-way emergency flashers, and get out of the vehicle.

Step 5: Do a Walk Around Inspection

Go to the front of the vehicle and check that the low beams are on and both 4-way flashers are working:

- Push the dimmer switch and check that the high beams work.
- Turn off the headlights and 4-way emergency flashers.
- Turn on the parking, clearance, side-marker, and identification lights.
- Turn on the right turn signal, and start the walk-around inspection.

General

- Walk around and inspect the vehicle.
- Clean all lights, reflectors, and glass as you go along.

Left Front Side

- Driver's door glass should be clean.
- Door latches and locks should work properly.

Left Front Wheel

- Condition of the wheel and rim—no missing, bent, or broken spacer studs, clamps, lugs, or any signs of misalignment.
- Condition of the tire—properly inflated, valve stem and cap intact and no serious cuts, bulges, or tread wear.
- Use a wrench to test rust-streaked lug nuts, indicating looseness.
- Hub oil level okay and no leaks.

Left Front Suspension

- Condition of the spring, spring hangers, shackles, and u-bolts.
- Shock absorber condition.

Left Front Brake

- Condition of the brake drum or disc.
- Condition of the hoses.

Front

- Condition of the front axle.
- Condition of the steering system.
 - No loose, worn, bent, damaged, or missing parts.
 - Must grab the steering mechanism to test for looseness.

Condition of the Windshield

- Check for damage and clean if dirty.
- Check the windshield wiper arms for proper spring tension.
- Check the wiper blades for damage, “stiff” rubber, and securement.

Lights and Reflectors

- Parking, clearance, and identification lights are clean, operating, and the proper color (amber at front).
- Reflectors are clean and the proper color (amber at front).
- Right front turn signal light is clean, operating, and the proper color (amber or white on signals facing forward).

Right Side

- Right front: check all items as done for the left front.
- Primary and secondary safety cab locks are engaged (if cab-over-engine design).
- Right fuel tank(s):
 - Securely mounted, and not damaged, or leaking.
 - Fuel crossover line is secure.
 - Tank(s) contain enough fuel.
 - Cap(s) are on and secure.

Condition of the Visible Parts

- Rear of the engine is not leaking.
- Transmission is not leaking.
- Exhaust system is secure, not leaking, and not touching wires, fuel, or air lines.
- Frame and cross members have no bends or cracks.
- Air lines and electrical wiring is secured against snagging, rubbing, or wearing.
- Spare tire carrier or rack is not damaged (if so equipped).
- Spare tire and/or wheel is securely mounted in rack.
- Spare tire and wheel is adequate (proper size, properly inflated).

Cargo Securement (Trucks)

- Cargo is properly blocked, braced, tied, chained, etc.
- Header board is adequate and secure (if required).
- Side boards and stakes are strong enough, free of damage, and properly set in place (if so equipped).
- Canvas or tarp (if required) is properly secured to prevent tearing, billowing, or blocking of mirrors.
- If oversize, all required signs (flags, lamps, and reflectors) are safely and properly mounted and all required permits are in the driver's possession.
- Curbside cargo compartment doors are in good condition, securely closed, latched/locked, and required security seals are in place.

Right Rear

- Condition of the wheels and rims—no missing, bent, or broken spacers, studs, clamps, or lugs.
- Condition of the tires—properly inflated, valve stems and caps intact, and no serious cuts, bulges, or tread wear, tires not rubbing each other, and nothing stuck between them.
- Tires are the same type (for example, not mixed radial and bias types).
- Tires are evenly matched (same size).
- Wheel bearing/seals are not leaking.

Suspension

- Condition of the spring(s), spring hangers, shackles, and u-bolts.
- Axle(s) are secure.
- Powered axle(s) are not leaking lube (gear oil).
- Condition of the torque rod arms and bushings.

- Condition of the shock absorber(s).
- If retractable axle equipped, check the condition of the lift mechanism. If air powered, check for leaks.
- Condition of the air ride components.

Brakes

- Brake adjustment.
- Condition of the brake drum(s) or discs.
- Condition of the hoses—look for any wear due to rubbing.

Lights and Reflectors

- Side-marker lights are clean, operating, and the proper color (red at rear, others amber).
- Side-marker reflectors are clean and the proper color (red at rear, others amber).

Rear

- Lights and reflectors.
 - Rear clearance and identification lights are clean, operating, and the proper color (red at rear).
 - Reflectors are clean and the proper color (red at rear).
 - Taillights are clean, operating, and the proper color (red at rear).
 - Right rear turn signals are operating, and the proper color (red, yellow, or amber at rear).
- License plate(s) is present, clean, and secured.
- Splash guards are present, not damaged, properly fastened, not dragging on the ground, and not rubbing the tires.
- Cargo is secure (trucks).
- Cargo is properly blocked, braced, tied, chained, etc.
- Tailboards are up and properly secured.
- End gates are free of damage and properly secured in stake sockets.
- Canvas or tarp (if required) is properly secured to prevent tearing, billowing, and blocking of either the rearview mirrors and rear lights.
- If over-length or over-width, make sure all signs and/or additional lights/flags are safely and properly mounted and all required permits are in the driver's possession.
- Rear doors are securely closed, latched, and locked.

Left Side

Check all items as done for the right side, plus:

- Battery(ies) (if not mounted in the engine compartment).
- Battery box(es) is securely mounted to vehicle.
- Box has a secure cover.
- Battery(ies) is secured against movement.
- Battery(ies) is not broken or leaking.
- Fluid in battery(ies) is at the proper level (except maintenance-free type).
- Cell caps are present and securely tightened (except maintenance-free type).
- Vents in the cell caps are free of foreign material (except maintenance-free type).

Step 6: Check the Signal Lights

Get in and Turn off the Lights

- Turn off all the lights.
- Turn on the stop lights (apply the trailer hand brake or have a helper press the brake pedal).
- Turn on the left turn signal lights.

Get out and Check the Lights

- Left front turn signal light is clean, operating, and the proper color (amber or white on signals facing the front).
- Left rear turn signal light and both stop lights are clean, operating, and the proper color (red, yellow, or amber).

NOTE: Checks of the brake, turn signal, and 4-way flasher functions must be done separately.

Get in the Vehicle

- Turn off the lights not needed for driving.
- Check for all the required papers, trip manifests, permits, etc.
- Secure all loose articles in the cab (they might interfere with the operation of the controls or hit you in an accident).
- Start the engine.

Step 7: Start the Engine and Check

Test for Hydraulic Leaks

If the vehicle has hydraulic brakes, pump the brake pedal 3 times. Then apply firm pressure to the pedal and hold for 5 seconds. The pedal should not move. If it does, there may be a leak or other problem. Get

it fixed before driving. If the vehicle has air brakes, do the checks described in Sections 5 and 6 of this handbook.

Brake System

Test the Parking Brake(s)

- Fasten the safety belt.
- Set the parking brake (power unit only).
- Release the trailer parking brake (if applicable).
- Place the vehicle into a low gear.
- Gently pull forward against the parking brake to make sure the parking brake holds.
- Repeat the same steps for the trailer with the trailer parking brake set and the power unit parking brakes released (if applicable).
- If it does not hold the vehicle, it is faulty. Get it fixed.

Test the Service Brake Stopping Action

- Drive the vehicle about 5 mph.
- Push the brake pedal firmly.
- “Pulling” to one side or the other can mean brake trouble.
- Any unusual brake pedal “feel” or delayed stopping action can mean trouble.
- If you find anything unsafe during the vehicle inspection, get it fixed. Federal and state laws forbid operating an unsafe vehicle.

2.1.6 – Inspection During a Trip

Check Vehicle Operation Regularly

You Should Check:

- Instruments.
- Air pressure gauge (if you have air brakes).
- Temperature gauges.
- Pressure gauges.
- Ammeter/voltmeter.
- Mirrors.
- Tires.
- Cargo and cargo covers.
- Lights.

If you see, hear, smell, or feel anything that might mean trouble, check it out.

Safety Inspection. Drivers of trucks and truck tractors transporting cargo must inspect the securement of the cargo within the first 50 miles of a trip and every 150 miles or every 3 hours after (whichever comes first).

2.1.7 – After-Trip Inspection and Report

You may have to make a written report each day on the condition of the vehicle(s) you drove. Report anything affecting safety or possibly leading to a mechanical breakdown.

The vehicle inspection report tells the motor carrier about problems that may need fixing. Keep a copy of your report in the vehicle for 1 day. That way, the next driver can learn about any problems you have found.

SUBSECTION 2.1

Test Your Knowledge

1. What is the most important reason for doing a vehicle inspection?
2. What things should you check during a trip?
3. Name some key steering system parts.
4. Name some suspension system defects.
5. What 3 kinds of emergency equipment must you have?
6. What is the minimum tread depth for front tires? For other tires?
7. Name some things you should check on the front of your vehicle during the walk around inspection test.
8. What should wheel bearing seals be checked for?
9. How many red reflective triangles should you carry?
10. How do you test hydraulic brakes for leaks?
11. Why put the starter switch key in your pocket during the vehicle inspection test?

These questions may be on your test. If you cannot answer them all, reread Subsection 2.1.

2.2 – BASIC CONTROL OF YOUR VEHICLE

To drive a vehicle safely, you must be able to control its speed and direction. Safe operation of a CMV requires skill in:

- Accelerating.
- Steering.
- Stopping.
- Backing safely.

Fasten your seatbelt when on the road. Apply the parking brake when you leave your vehicle.

2.2.1 – Accelerating

Do not roll back when you start. You may hit someone behind you. If you have a manual transmission vehicle, partly engage the clutch before you take your right foot off the brake. Apply the parking brake whenever necessary to keep from rolling back. Release the parking brake only when you have applied enough engine power to keep from rolling back. On a tractor-trailer equipped with a trailer brake hand valve, the hand valve can be applied to keep from rolling back.

Speed up smoothly and gradually so the vehicle does not jerk. Rough acceleration can cause mechanical damage. When pulling a trailer, rough acceleration can damage the coupling. When starting a bus on a level surface with good traction, there is often no need for the parking brake.

Speed up very gradually when traction is poor, as in rain or snow. If you use too much power, the drive wheels may spin and you could lose control. If the drive wheels begin to spin, take your foot off the accelerator.

2.2.2 – Steering

Hold the steering wheel firmly with both hands on opposite sides of the wheel. If you hit a curb or pothole (chuckhole), the wheel could pull away from your hands unless you have a firm hold.

2.2.3 – Stopping

Push the brake pedal down gradually. The amount of brake pressure you need to stop the vehicle will depend on the speed of the vehicle and how quickly you need to stop. Control the pressure so the vehicle comes to a smooth, safe stop. If you have a manual transmission, push the clutch in when the engine is close to idle.

2.2.4 – Backing Safely

Because you cannot see everything behind your vehicle, backing is always dangerous. Avoid backing whenever you can. When you park, try to park so you will be able to pull forward when you leave. When you have to back, here are a few simple safety rules:

- Start in the proper position.
- Look at your path.
- Use the mirrors on both sides.
- Back slowly.
- Back and turn toward the driver's side whenever possible.
- Use a helper whenever possible.

These rules are discussed as follows.

Start in the Proper Position. Put the vehicle in the best position to allow you to back safely. This position will depend on the type of backing to be done.

Look at Your Path. Look at your line of travel before you begin. Get out and walk around the vehicle. Check your clearance to the sides, overhead, in, and near the path your vehicle will take.

Use Mirrors on Both Sides. Check the outside mirrors on both sides frequently. Get out of the vehicle and check your path if you are unsure.

Back Slowly. Always back as slowly as possible. Use the lowest reverse gear. That way you can easily correct any steering errors. You also can stop quickly, if necessary.

Back and Turn Toward the Driver's Side. Back toward the driver's side so you can see better. Backing toward the right side is very dangerous because you cannot see as well. If you back and turn toward the driver's side, you can watch the rear of your vehicle by looking out the side window. Use driver-side backing—even if it means going around the block to put your vehicle in this position. The added safety is worth it.

Use a Helper. Use a helper when you can. There are blind spots you cannot see. That is why a helper is important. The helper should stand near the back of your vehicle where you can see them. Before you begin backing, work out a set of hand signals that you both understand. Agree on a signal for “stop.”

2.2.5 – Backing with a Trailer

When backing a car, straight truck, or bus, turn the steering wheel toward the direction you want to go. When backing a trailer, turn the steering wheel in the opposite direction. Once the trailer starts to turn, you must turn the wheel the other way to follow the trailer.

Whenever you back with a trailer, try to position your vehicle so you can back in a straight line. If you must back on a curved path, back toward the driver's side so you can see. Back slowly so you can make corrections before you get too far off course.

Correct Drift Immediately. As soon as you see the trailer getting off the proper path, correct it by turning the steering wheel in the direction of the drift.

Pull Forward. When backing, make pull-ups to reposition your vehicle when needed.

2.3 – SHIFTING GEARS

Correct shifting of gears is important. If you cannot get your vehicle into the right gear while driving, you will have less control.

2.3.1 – Manual Transmissions

Basic Method for Shifting Up. Most heavy vehicles with unsynchronized manual transmission require double clutching to change gears. If equipped with a synchronized manual transmission, double clutching is **not** required. This is the method:

- Release the accelerator, push in the clutch, and shift to Neutral at the same time.
- Release the clutch.
- Let the engine and gears slow down to the revolutions per minute (rpm) required for the next gear (this takes practice).
- Push in the clutch and shift to the higher gear at the same time.
- Release the clutch and press the accelerator at the same time.

Shifting gears using double clutching requires practice. If you remain too long in Neutral, you may have difficulty putting the vehicle into the next gear. If so, do not try to force it. Return to Neutral, release the clutch, increase the engine speed to match the road speed, and try again.

Knowing When to Shift Up. There are 2 ways of knowing when to shift:

- **Use Engine Speed (rpm).** Study the driver's manual for your vehicle and learn the operating rpm range. Watch your tachometer, and shift up when your engine reaches the top of the range. (Some newer vehicles use "progressive" shifting: the rpm at which you shift becomes higher as you move up in the gears. Find out what is right for the vehicle you will operate.)
- **Use Road Speed (mph).** Learn what speeds each gear is good for. Then, by using the speedometer, you will know when to shift up.

With either method, you may learn to use engine sounds to know when to shift.

Basic Procedures for Shifting Down

- Release the accelerator, push in the clutch, and shift to Neutral at the same time.
- Release the clutch.
- Press the accelerator and increase the engine and gear speed to the rpm required in the lower gear.
- Push in the clutch and shift to the lower gear at the same time.
- Release the clutch and press the accelerator at the same time.

Downshifting, like upshifting, requires knowing when to shift. Use either the tachometer or speedometer and downshift at the right rpm or road speed.

Special conditions where you should downshift are:

Before Starting Down a Hill. Slow down and shift down to a speed that you can control without using the brakes hard. Otherwise, the brakes can overheat and lose their braking power. Make sure you are in a low enough gear, usually lower than the gear required to climb the same hill.

Before Entering a Curve. Slow down to a safe speed, and downshift to the right gear. This lets you use some power through the curve to help the vehicle be more stable while turning. It also allows you to speed up as soon as you are out of the curve.

2.3.2 – Multi-Speed Rear Axles and Auxiliary Transmissions

Multi-speed rear axles and auxiliary transmissions are used on many vehicles to provide extra gears. You usually control them by a selector knob or switch on the gearshift lever of the main transmission. There are many different shift patterns. Learn the right way to shift gears in the vehicle you will drive.

2.3.3 – Automatic Transmissions

Some vehicles have automatic transmissions. You can select a low range to get greater engine braking when going down grades. The lower ranges prevent the transmission from shifting up beyond the selected gear (unless the governor rpm is exceeded). It is very important to use this braking effect when going down grades.

2.3.4 – Retarders

Some vehicles have "retarders." Retarders help slow a vehicle, reducing the need for using your brakes. They reduce brake wear and give you another way to slow down. There are 4 basic types of retarders (exhaust, engine, hydraulic, and electric). All retarders can be turned on or off by the driver. On some vehicles, the retarding power can be adjusted. When turned "on," retarders apply their braking power (to the drive wheels only) whenever you let up on the accelerator pedal all the way.

Because these devices can be noisy, be sure you know where their use is permitted.

Caution: When your drive wheels have poor traction, the retarder may cause them to skid. Therefore, you should turn the retarder off whenever the road is wet, icy, or snow covered.

////////////////////////////////////

SUBSECTIONS 2.2 AND 2.3

Test Your Knowledge

1. Why should you back toward the driver's side?
2. If stopped on a hill, how can you start moving without rolling back?
3. When backing, why is it important to use a helper?
4. What is the most important hand signal that you and the helper should agree on?
5. What are the 2 special conditions where you should downshift?
6. When should you downshift automatic transmissions?
7. Retarders keep you from skidding when the road is slippery. True or False?
8. What are the 2 ways to know when to shift?

These questions may be on the test. If you cannot answer them all, reread Subsections 2.2 and 2.3.

////////////////////////////////////

2.4 – SEEING

To be a safe driver you need to know what is going on all around your vehicle. Not looking properly is a major cause of accidents.

2.4.1 – Seeing Ahead

All drivers look ahead, but many do not look far enough ahead.

Importance of Looking far Enough Ahead. Because stopping or changing lanes can take a lot of distance, knowing what the traffic is doing on all sides of you is very important. You need to look well ahead to make sure you have room to make these moves safely.

How far Ahead to Look. Most good drivers look at least 12 to 15 seconds ahead. That means looking ahead of the distance you will travel in 12 to 15 seconds. At lower speeds, that is about one block. At highway speeds, it is about a quarter of a mile. If you are not looking that far ahead, you may have to stop too quickly or make quick lane changes. Looking 12 to 15 seconds ahead does not mean not paying attention to things that are closer. Good drivers shift their attention back and forth, near and far. Figure 2.6 illustrates how far to look ahead.

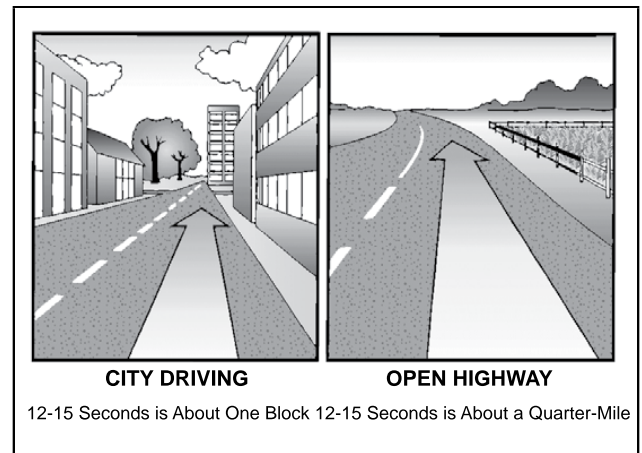

Figure 2.6

Look for Traffic. Look for vehicles coming onto the highway, into your lane, or turning. Watch for brake lights from slowing vehicles. By seeing these things far enough ahead, you can adjust your speed, or change lanes if necessary to avoid a problem. If a traffic light has been green for a long time, it will probably change before you get there. Start slowing down and be ready to stop.

Road Conditions. Look for hills and curves—anything for which you will have to slow or change lanes. Pay attention to traffic signals and signs. Traffic signs may alert you to road conditions where you may have to change speed.

2.4.2 – Seeing to the Sides and Rear

It is important to know what is going on behind and to the sides of you. Check your mirrors regularly. Check more often in special situations.

Every California registered motor vehicle must have at least 2 mirrors, including 1 attached to the left-hand side, and located to give a clear view of the roadway to the rear for a distance of at least 200 feet. Both left and right-hand rear view mirrors are required on a motor vehicle that is constructed or loaded to obscure the driver’s view to the rear, or is towing a vehicle or load that blocks the view (CVC §26709).

How to Use Mirrors. Use mirrors correctly by checking them quickly and understanding what you see.

When using your mirrors while driving on the road, check them quickly. Look back and forth between the mirrors and the road ahead. Do not focus on the mirrors for too long. Otherwise, you will travel quite a distance without knowing what is happening ahead. Many large vehicles have curved (convex, “fisheye,” “spot,” “bugeye”) mirrors that show a wider area than flat mirrors. This is often helpful. However, everything appears smaller in a convex mirror than it would

if you were looking at it directly. Things also seem farther away than they really are. It is important to realize this and to allow for it. Figure 2.7 shows the field of vision using a convex mirror.

Mirror Adjustment. Mirror adjustment should be checked prior to the start of any trip and can only be checked accurately when the trailer(s) are straight. You should check and adjust each mirror to show some part of the vehicle. This will give you a reference point for judging the position of the other images.

Regular Checks. Make regular checks of your mirrors to be aware of traffic and to check your vehicle.

Traffic. Check your mirrors for vehicles on either side and behind you. In an emergency, you may need to know whether you can make a quick lane change. Use your mirrors to spot overtaking vehicles. There are “blind spots” that your mirrors cannot show you. Check your mirrors regularly to know where other vehicles are around you, and to see if they move into your blind spots.

Check Your Vehicle. Use the mirrors to keep an eye on your tires. It is one way to spot a tire fire. If you are carrying open cargo, you can use the mirrors to check it. Look for loose straps, ropes, or chains. Watch for a flapping or ballooning tarp.

Special Situations. Special situations require more than regular mirror checks. These are lane changes, turns, merges, and tight maneuvers.

Lane Changes. Check your mirrors to make sure no one is alongside or about to pass you. Check your mirrors:

- Before you change lanes to make sure there is enough room.
- After you signaled to check that no one has moved into your blind spot.
- Right after you start the lane change to double-check that your path is clear.
- After you complete the lane change.

Turns. In turns, check your mirrors to make sure the rear of your vehicle will not hit anything.

Merges. When merging, use your mirrors to make sure the gap in traffic is large enough for you to enter safely.

Tight Maneuvers. Any time you are driving in close quarters, check your mirrors often. Make sure you have enough clearance.

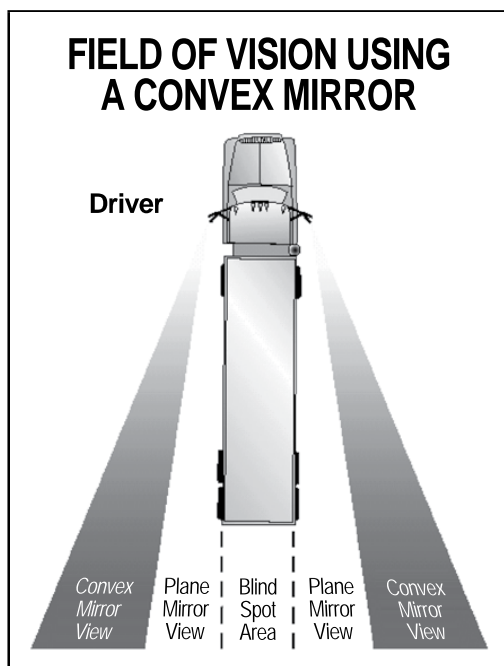

Figure 2.7

2.5 – COMMUNICATING

2.5.1 – Signal Your Intentions

Other drivers cannot know what you are going to do until you tell them.

Signaling what you intend to do is important for safety. Here are some general rules for signaling.

Turns. There are 3 good rules for using turn signals:

1. **Signal Early.** Signal well before you turn. It is the best way to keep others from trying to pass you.
2. **Signal Continuously.** You need both hands on the wheel to turn safely. Do not cancel the signal until you have completed the turn.
3. **Cancel Your Signal.** Do not forget to turn off your turn signal after you have turned (if you do not have self-canceling signals).

NOTE: For information on vehicles that must be equipped with lamp turn signal systems and 2 stop lamps, see CVC §§24951 and 24600.

Lane Changes. Put your turn signal on before changing lanes. Change lanes slowly and smoothly. That way, a driver you did not see may have a chance to honk their horn, or avoid your vehicle.

Slowing Down. Warn drivers behind you when you see you will need to slow down. A few light taps on the brake pedal—enough to flash the brake lights—should warn following drivers. Use the 4-way emergency flashers for times when you are driving very slowly or are stopped. Warn other drivers in any of the following situations:

- **Trouble Ahead.** The size of your vehicle may make it hard for drivers behind you to see hazards ahead. If you see a hazard that will require slowing down, warn the drivers behind by flashing your brake lights.
- **Tight Turns.** Most car drivers do not know how slow you have to go to make a tight turn in a large vehicle. Give drivers behind you warning by braking early, slowly, and gradually.
- **Stopping on the Road.** Truck and bus drivers sometimes stop in the roadway to unload cargo or passengers, or to stop at a railroad crossing. Warn following drivers by flashing your brake lights. Do not stop suddenly.

- **Driving Slowly.** Drivers often do not realize how fast they are catching up to a slow vehicle until they are very close. If you must drive slowly, alert following drivers by turning on your emergency flashers if it is legal. (Laws regarding the use of flashers differ from one state to another. Check the laws of the states where you will drive).

Do Not Direct Traffic. Some drivers try to help out others by signaling when it is safe to pass. You should not do this, it could cause an accident. You could be blamed and it could cost you many thousands of dollars.

2.5.2 – Communicating Your Presence

Other drivers may not notice your vehicle, even when in plain sight. To help prevent accidents, let them know you are there.

When Passing. Whenever you are about to pass a vehicle, pedestrian, or bicyclist, assume they do not see you. They could suddenly move in front of you. When it is legal, tap the horn lightly or, at night, flash your lights from low to high beam and back. Drive carefully enough to avoid an accident, even if they do not see or hear you.

When It Is Hard to See. At dawn, dusk, in rain, or snow, you need to make yourself easier to see. If you are having trouble seeing other vehicles, other drivers will have trouble seeing you. Turn on your lights, use the headlights, not just the identification or clearance lights. Use the low beams: high beams can bother people in the daytime as well as at night.

When Parked at the Side of the Road. When you pull off the road and stop, be sure to turn on the 4-way emergency flashers. This is important at night. Do not trust the taillights to give warning. Drivers have crashed into the rear of a parked vehicle because they thought it was moving normally.

If you must stop on a road or the shoulder of any road, you must put out your emergency warning devices within 10 minutes. Place your warning devices at the following locations:

- If you must stop on or by a one-way or divided highway, place warning devices 10 feet, 100 feet, and 200 feet toward the approaching traffic. See Figure 2.8.

- If you stop on a 2-lane road carrying traffic in both directions or on an undivided highway, place warning devices within 10 feet of the front or rear corners to mark the location of the vehicle and 100 feet behind and ahead of the vehicle, on the shoulder or in the lane you stopped in. See Figure 2.9.
- Back beyond any hill, curve, or other obstruction that prevents other drivers from seeing the vehicle within 500 feet. If line of sight view is obstructed due to hill or curve, move the rear-most triangle to a point back down the road so warning is provided. See Figure 2.10.

When putting out the triangles, hold them between yourself and the oncoming traffic for your own safety. (So other drivers can see you.)

Use Your Horn When Needed. Your horn can let others know you are there. It can help to avoid an accident. Use your horn when needed. However, it can startle others and be dangerous when used unnecessarily.

2.6 – CONTROLLING YOUR SPEED

Driving too fast is a major cause of fatal accidents. You must adjust your speed depending on driving conditions. These include traction, curves, visibility, traffic, and hills.

2.6.1 – Stopping Distance

Perception Distance + Reaction Distance + Braking Distance = Total Stopping Distance

- **Perception Distance.** This is the distance your vehicle travels, in ideal conditions, from the time your eyes see a hazard until your brain recognizes it. Keep in mind, certain mental and physical conditions can affect your perception distance. It can be affected greatly, depending on visibility and the hazard itself. The average perception time for an alert driver is 1 3/4 seconds. At 55 mph, this accounts for 142 feet traveled.
- **Reaction Distance.** This is the distance you will continue to travel, in ideal conditions, before you physically hit the brakes, in response to a hazard seen ahead. The average driver has a reaction time of 3/4 second to 1 second. At 55 mph, this accounts for 61 feet traveled.

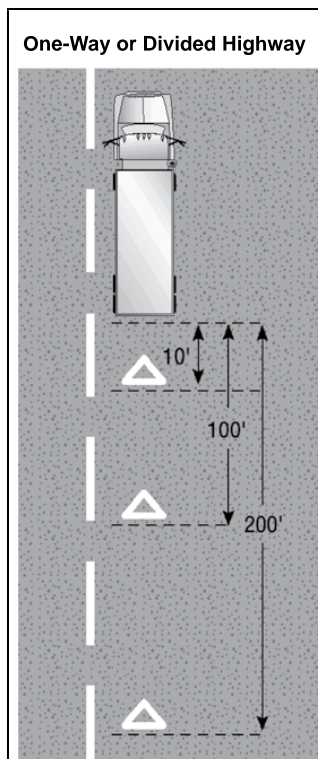

Figure 2.8

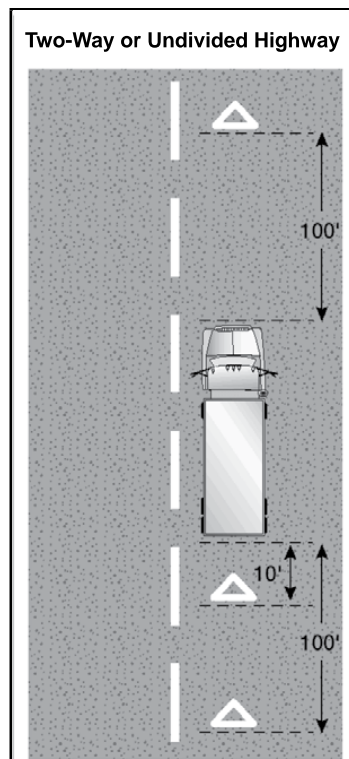

Figure 2.9

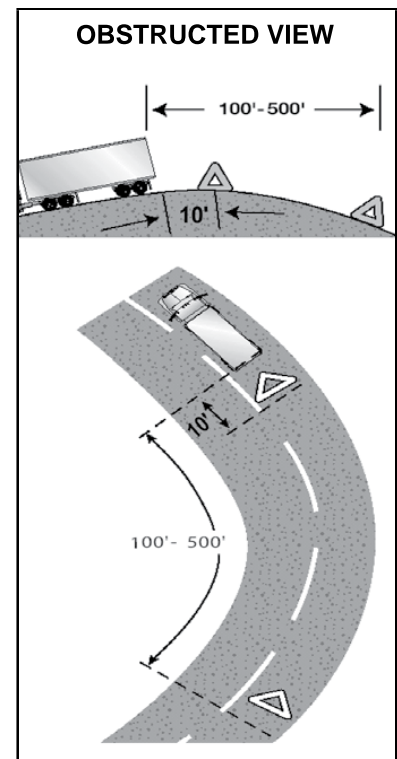

Figure 2.10

- **Braking Distance.** This is the distance your vehicle will travel, in ideal conditions, while you are braking. At 55 mph, on dry pavement with good brakes, it can take about 216 feet.
- **Total Stopping Distance.** The total minimum distance your vehicle has traveled, in ideal conditions, with everything considered, including perception distance, reaction distance, and braking distance, until you can bring your vehicle to a complete stop. At 55 mph, your vehicle will travel a minimum of 419 feet. Figure 2.11 shows the American football field in using distance.

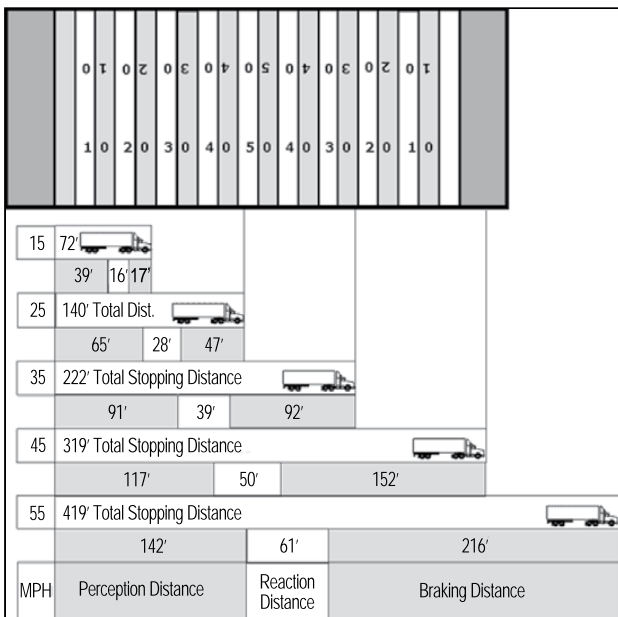

Figure 2.11

Effect of Speed on Stopping Distance. The faster you drive, the greater the impact or striking power of your vehicle. When you double your speed from 20 to 40 mph, the impact is 4 times greater. The braking distance is also 4 times longer. Triple the speed from 20 to 60 mph and the impact and braking distance is 9 times greater. At 60 mph, your stopping distance is greater than the length of an American football field. Increase the speed to 80 mph and the impact and braking distance are 16 times greater than at 20 mph. High speeds greatly increase the severity of accidents and stopping distances. By slowing down, you can reduce braking distance.

Effect of Vehicle Weight on Stopping Distance. The heavier the vehicle, the more work the brakes must do to stop it and the more heat they absorb. The brakes, tires, springs, and shock absorbers on heavy vehicles are designed to work best when the vehicle is fully loaded. Empty trucks require greater stopping distances because an empty vehicle has less traction.

Control and Stopping Requirements. The service brake must hold the vehicle or combination of vehicles stationary on any grade on which it is operated under all conditions of loading or unloading (CVC §26454).

The service brakes of every motor vehicle or combination of vehicles must be capable of stopping from an initial speed of 20 mph as follows maximum stopping distance (MSD) in feet:

- Passenger vehicle—25 MSD
- Single motor vehicle with a manufacturer's GVWR of less than 10,000 pounds—30 MSD
- Single motor vehicle with a manufacturer's GVWR of 10,000 pounds or more, or any bus—40 MSD
- Combination of vehicles consisting of a passenger vehicle or any motor vehicle with a manufacturer's GVWR of less than 10,000 pounds in combination with any trailer, semitrailer, or trailer coach—40 MSD
- All other combinations of vehicles—50 MSD

2.6.2 – Matching Speed to the Road Surface

You cannot steer or brake a vehicle unless you have traction. Traction is friction between the tires and the road. Some road conditions reduce traction and call for lower speeds.

Slippery Surfaces. It will take longer to stop, and it will be harder to turn without skidding, when the road is slippery. Wet roads can double stopping distance. You must drive slower to be able to stop in the same distance as on a dry road. Reduce speed by about 1/3 (for example, slow from 55 to about 35 mph) on a wet road. On packed snow, reduce speed by a half or more. If the surface is icy, reduce speed to a crawl and stop driving as soon as you can safely do so.

Identifying Slippery Surfaces. Sometimes it is hard to know if the road is slippery. Here are some signs of slippery roads:

- **Shaded Areas.** Shady parts of the road will remain icy and slippery long after open areas have melted.
- **Bridges.** When the temperature drops, bridges will freeze before the road will. Be especially careful when the temperature is close to 32 degrees Fahrenheit.
- **Melting Ice.** Slight melting will make ice wet. Wet ice is much more slippery than ice that is not wet.
- **Black Ice.** Black ice is a thin layer that is clear enough that you can see the road underneath it. It makes the road look wet. Any time the temperature is below freezing and the road looks wet, watch out for black ice.
- **Vehicle Icing.** An easy way to check for ice is to open the window and feel the front of the mirror, mirror support, or antenna. If there is ice on these, the road surface is probably starting to ice up.
- **Just After Rain Begins.** Right after it starts to rain, the water mixes with oil left on the road by vehicles. This makes the road very slippery. If the rain continues, it will wash the oil away.

Hydroplaning. In some weather, water or slush collects on the road. When this happens, your vehicle can hydroplane. It is like water skiing—the tires lose their contact with the road and have little or no traction. You may not be able to steer or brake. You can regain control by releasing the accelerator and pushing in the **clutch**. This will slow your vehicle and let the wheels turn freely. If the vehicle is hydroplaning, do not use the brakes to slow down. If the drive wheels start to skid, push in the clutch to let them turn freely.

It does not take a lot of water to cause hydroplaning. Hydroplaning can occur at speeds as low as 30 mph if there is a lot of water. Hydroplaning is more likely if tire pressure is low, or tread is worn. (The grooves in a tire carry away the water: if the grooves are not deep, they do not work well.)

Road surfaces where water may collect can create conditions that cause a vehicle to hydroplane. Watch for clear reflections, tire splashes, and raindrops on the road. These are indications of standing water.

2.6.3 – Speed and Curves

Drivers must adjust their speed for curves in the road. If you take a curve too fast, 2 things can happen. The tires can lose their traction and continue straight ahead, so you skid off the road. Or, the tires may keep their traction and the vehicle rolls over.

Slow to a safe speed before you enter a curve. Braking in a curve is dangerous because it is easier to lock the wheels and cause a skid. Slow down as needed. Do not ever exceed the posted speed limit for the curve. Be in a gear that will let you accelerate slightly in the curve. This will help you keep control.

2.6.4 – Speed and Distance Ahead

You should always be able to stop within the distance you can see ahead. Fog, rain, or other conditions may require that you slow down to be able to stop in the distance you can see. At night, you cannot see as far with low beams as you can with high beams. Slow down when you must use low beams.

2.6.5 – Speed and Traffic Flow

When you are driving in heavy traffic, the safest speed is the speed of other vehicles. Vehicles going the same direction at the same speed are not likely to run into one another. In California, speed limits are lower for trucks and buses than for cars. It can vary as much as 15 mph. Use extra caution when you change lanes or pass on these roadways. Drive at the speed of the traffic, if you can without going at an illegal or unsafe speed. Keep a safe following distance.

The main reason drivers exceed speed limits is to save time. Anyone trying to drive faster than the speed of traffic will not be able to save much time. The risks involved are not worth it. If you go faster than the speed of other traffic, you will have to keep passing other vehicles. This increases the chance of an accident, and it is more tiring. Fatigue increases the chance of an accident. Going with the flow of traffic is safer and easier.

2.6.6 – Speed on Downgrades

Your vehicle's speed will increase on downgrades because of gravity. Your most important objective is to select and maintain a speed that is not too fast for the:

- Total weight of the vehicle and cargo.
- Length of the grade.
- Steepness of the grade.
- Road conditions.
- Weather.

If a speed limit is posted, or there is a sign indicating "Maximum Safe Speed," never exceed the speed shown. Also, look for and heed warning signs indicating the length and steepness of the grade. You must use the braking effect of the engine as the principal way of controlling your speed on downgrades. The braking effect of the engine is greatest when it is near the governed rpms and the transmission is in the lower gears. Save your brakes so you will be able to slow or stop as required by road and traffic conditions. Shift your transmission to a low gear before starting down the grade and use the proper braking techniques. Carefully read the information on going down long, steep downgrades safely in Subsections 2.16 Mountain Driving in this handbook.

2.6.7 – Roadway Work Zones

Speeding traffic is the number one cause of injury and death in roadway work zones. Observe the posted speed limits at all times when approaching and driving through a work zone. Watch your speedometer, and do not allow your speed to creep up as you drive through long sections of road construction. Decrease your speed for adverse weather or road conditions. Decrease your speed even further when a worker is close to the roadway.

2.6.8 – Overtaking or Following Another Vehicle

You may not overtake and pass another vehicle which is moving at less than 20 mph on a grade (outside a business or residential district) unless you can pass that vehicle at least 10 mph faster than it is traveling and the pass can be completed within 1/4 mile (CVC §21758). You must not follow the vehicles listed below any closer than 300 feet. The rule does not apply during overtaking and passing, when there are 2 or more lanes for traffic in each direction, or in a business or residential district (CVC §21704).

- A motor truck or truck tractor having 3 or more axles.
- Any motor truck or truck tractor towing any other vehicle.
- A passenger vehicle or bus towing any other vehicle.
- A school bus transporting any school pupil.
- A farm labor vehicle when transporting passengers.
- A vehicle transporting explosives.
- A trailer bus.

When large vehicles are being driven in caravan on the open highway, at least 100 feet must be left between them to allow other vehicles to overtake and pass them (CVC §21705).

SUBSECTIONS 2.4, 2.5, AND 2.6

Test Your Knowledge

1. How far ahead does the handbook say you should look?
2. What are two main things to look for ahead?
3. What's your most important way to see the sides and rear of your vehicle?
4. What does "communicating" mean in safe driving?
5. Where should your reflectors be placed when stopped on a divided highway?
6. What 3 things add up to total stopping distance?
7. If you go twice as fast, will your stopping distance increase by 2 or 4 times?
8. Empty trucks have the best braking. True or False?
9. What is hydroplaning?
10. What is black ice?

These questions may be on the test. If you cannot answer them all, reread Subsections 2.4, 2.5, and 2.6.

2.7 – MANAGING SPACE

You need space all around your vehicle to be a safe driver. When things go wrong, space gives you time to think and take action.

You need to manage space to have space available when something goes wrong. While this is true for all drivers, it is very important for large vehicles. They take up more space and require more space for stopping and turning.

2.7.1 – Space Ahead

Of all the space around your vehicle, the space you are driving into, is most important.

Need for Space Ahead. You need space ahead in case you must suddenly stop. Remember, if the vehicle ahead of you is smaller than yours, it can probably stop faster than you can. You may crash if you are following too closely.

How Much Space? How much space should you keep in front of you? One good rule says you need at least 1 second for each 10 feet of vehicle length at speeds below 40 mph. At greater speeds, you must add 1 second for safety. For example, if you are driving a 40-foot vehicle, you should leave 4 seconds

between you and the vehicle ahead. In a 60-foot rig, you will need 6 seconds. Over 40 mph, you would need 5 seconds for a 40-foot vehicle and 7 seconds for a 60-foot vehicle. See Figure 2.12.

To know how much space you have, wait until the vehicle ahead passes a shadow on the road, a pavement marking, or some other clear landmark. Then count off the seconds like this: “one thousand-and-one, one thousand-and-two” and so on, until you reach the same spot. Compare your count with the rule of 1 second for every 10 feet of length.

If you are driving a 40-foot truck and only counted up to 2 seconds, you are too close. Drop back a little and count again until you have 4 seconds of following distance (or 5 seconds, if you are going over 40 mph). After a little practice, you will know how far back you should be. Remember to add 1 second for speeds above 40 mph. Also, remember that when the road is slippery, you need more space to stop.

2.7.2 – Space Behind

You cannot stop others from following you too closely, but there are things you can do to make it safer.

- **Stay to the Right.** Heavy vehicles are often tailgated when they cannot keep up with the speed of traffic. This often happens when you are going uphill. If a heavy load is slowing you down, stay in the right lane if you can. Going uphill, you should not pass another slow vehicle unless you can get around quickly and safely.
- **Dealing With Tailgaters Safely.** In a large vehicle, it is often hard to see whether a vehicle is close behind you. You may be tailgated:
 - **When you are Traveling Slowly.** Drivers trapped behind slow vehicles often follow closely.
 - **In Bad Weather.** Many small vehicle drivers follow large vehicles closely during bad weather, especially when it is hard to see the road ahead.

If you find yourself being tailgated, here are some things you can do to reduce the chances of an accident:

Avoid Quick Changes. If you have to slow down or turn, signal early, and reduce speed very gradually.

Increase Your Following Distance. Open up room in front of you to help you avoid having to make sudden speed or direction changes. It also makes it easier for the tailgater to get around you.

HEAVY VEHICLE FORMULA
For timed interval following distance

- 1 second required for each 10 feet off vehicle length at speeds under 40 MPH
- Above 40 MPH use same formula, then add 1 second for the additional speed

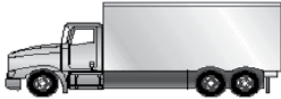

40 foot truck (under 40 MPH) = 4 seconds



50 foot truck (above 40 MPH) = 6 seconds



60 foot truck (under 40 MPH) = 6 seconds

Figure 2.12

Do Not Speed Up. It is safer to be tailgated at a low speed than a high speed.

Avoid Tricks. Do not turn on your taillights or flash your brake lights. Follow the suggestions above.

2.7.3 – Space to the Sides

CMVs are often wide and take up most of a lane. Safe drivers will manage what little space they have. You can do this by keeping your vehicle centered in your lane, and avoiding driving alongside others.

Staying Centered in a Lane. Keep your vehicle centered in the lane to keep a safe clearance on either side. If your vehicle is wide, you have little room to spare.

Traveling Next to Others. There are 2 dangers in traveling alongside other vehicles:

- Another driver may change lanes suddenly and turn into you.
- You may be trapped when you need to change lanes.

Find an open spot where you are not near other traffic. When traffic is heavy, it may be hard to find an open spot. If you must travel near other vehicles, try to keep as much space as possible between you and them. Also, drop back or pull forward so that you are sure the other driver can see you.

Strong Winds. Strong winds make it difficult to stay in your lane. The problem is usually worse for lighter vehicles. This problem can be especially bad coming out of tunnels. Do not drive alongside others if you can avoid it.

2.7.4 – Space Overhead

Hitting overhead objects is a danger. Make sure you always have overhead clearance.

- Do not assume that the heights posted at bridges and overpasses are correct. Repaving or packed snow may have reduced the clearances since the heights were posted.
- The weight of a cargo van changes its height. An empty van is higher than a loaded one. Clearing under a bridge when your CMV was loaded **does** not mean it will clear when you are empty.
- If you doubt you have safe space to pass under an object, go slowly. If you are not sure you can make it, take another route. Warnings are often posted on low bridges or underpasses, but sometimes they are not.

- Some roads can cause a vehicle to tilt. There can be a problem clearing objects along the edge of the road, such as signs, trees, or bridge supports. Where this is a problem, drive a little closer to the center of the road.
- Before you back into an area, get out and check for overhanging objects such as branches or electric wires. It is easy to miss seeing them while you are backing. Also, check for other hazards at the same time.

2.7.5 – Space Below

Many drivers forget about the space under their vehicles. This space can be very small when a vehicle is heavily loaded. This is often a problem on dirt roads and unpaved yards. Do not take a chance on getting hung up. Drainage channels across roads can cause the ends of some vehicles to drag. Cross such depressions carefully.

Railroad tracks can also cause problems, particularly when pulling trailers with a low underneath clearance. Do not take a chance on getting hung up halfway across.

2.7.6 – Space for Turns

The space around a truck or bus is important in turns. Large vehicles can hit other vehicles or objects during turns because of wide turning and off-tracking.

Right Turns. Here are some rules to help prevent right-turn accidents:

- Turn slowly to give yourself and others more time to avoid problems.
- If you are driving a truck or bus that cannot make the right turn without swinging into another lane, turn wide as you complete the turn. Keep the rear of your vehicle close to the curb. This will stop other drivers from passing you on the right.
- Do not turn wide to the left as you start the turn. A following driver may think you are turning left and try to pass you on the right. You may crash into the other vehicle as you complete your turn.
- If you must cross into the oncoming lane to make a turn, watch out for vehicles coming toward you. Give them room to go by or stop. However, do not back up for them because you might hit someone behind you. See Figure 2.13.

Left Turns. On a left turn, make sure you reach the center of the intersection before you start the left turn. If you turn too soon, the left side of your vehicle may hit another vehicle because of off-tracking.

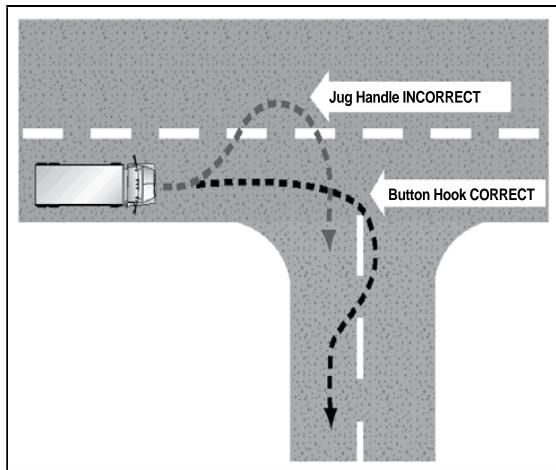

Figure 2.13

If there are 2 turning lanes, always take the right turn lane. Do not start in the inside lane because you may have to swing right to make the turn. Drivers on your left can be more readily seen. See Figure 2.14.

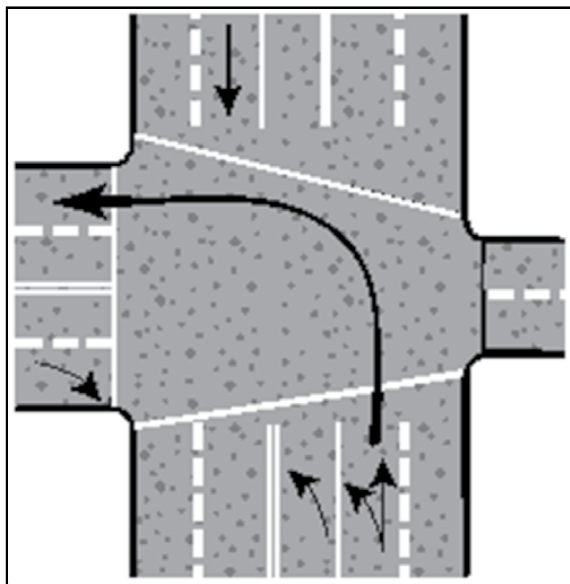

Figure 2.14

2.7.7 – Space Needed to Cross or Enter Traffic

Be aware of the size and weight of your vehicle when you cross or enter traffic. Here are some important things to keep in mind:

- Because of slow acceleration and the space large vehicles require, you may need a much larger gap to enter traffic than you would in a car.
- Acceleration varies with the load. Allow more room if your vehicle is heavily loaded.
- Before you start across a road, make sure you can get all the way across before traffic reaches you.

2.8 – SEEING HAZARDS

2.8.1 – Importance of Seeing Hazards

What is a Hazard? A hazard is any road condition or other road user (driver, motorcyclist, bicyclist, and pedestrian) that is a possible danger. For example, a vehicle in front of you is headed toward the freeway exit, the brake lights come on and they begin braking hard. This could mean the driver is uncertain about taking the off ramp. They might suddenly return to the highway. This vehicle is a hazard. If the vehicle cuts in front of you, it is no longer just a hazard; it is an emergency.

Seeing Hazards Lets you be Prepared. You will have more time to act if you see hazards before they become emergencies. In the example above, you might make a lane change or slow down to prevent an accident if the vehicle suddenly cuts in front of you. Seeing this hazard gives you time to check your mirrors and signal a lane change. Being prepared reduces the danger. A driver who did not see the hazard until the slow vehicle pulled back on the highway in front of them would have to do something very suddenly. Sudden braking or a quick lane change is more likely to lead to an accident.

Learning to See Hazards. There are often clues to help you see hazards. The more you drive, the better you can learn to see hazards. This section will talk about hazards that you should be aware of.

2.8.2 – Hazardous Roads

Move-Over Laws

The incidents of law enforcement officers, emergency medical services, fire department personnel, and people working on the road being struck while performing duties at the roadside are increasing at a frightening pace. Move-over laws have been enacted, which require drivers to slow and change lanes when approaching a roadside incident, to lessen the problem. Signs are posted on roadways in states that have such laws.

When approaching an authorized emergency vehicle stopped on the roadside or a work zone, proceed with caution by slowing and yielding the right-of-way by changing into a lane not next to that of the authorized emergency vehicle or work zone if safety and traffic conditions permit. If a lane change is unsafe, slow down and proceed with caution while maintaining a safe speed for traffic conditions.

In California, failing to obey the move-over law is an infraction, punishable by a fine (CVC §21809).

Slow down and be very careful if you see any of the following road hazards:

- **Work Zones.** When people are working on the road, it is a hazard. There may be narrower lanes, sharp turns, or uneven surfaces. Other drivers are often distracted and drive unsafely. Workers and construction vehicles may get in the way. Drive slowly and carefully near work zones. Use your 4-way emergency flashers or brake lights to warn drivers behind you.
- **Drop Off.** Sometimes the pavement drops off sharply near the edge of the road. Driving too near the edge can tilt your vehicle toward the side of the road. This can cause the top of your vehicle to hit roadside objects (such as signs, or tree limbs). Also, it can be hard to steer as you cross the drop off, go off the road, or come back on.
- **Foreign Objects.** Things that have fallen on the road can be hazards. They can be a danger to your tires and wheel rims. They can damage electrical and brake lines. They can be caught between dual tires and cause severe damage. Some obstacles that appear to be harmless can be very dangerous. For example, cardboard boxes may be empty, but they may also contain some solid or heavy material capable of causing damage. The same is true of paper and cloth sacks. It is important to remain alert for objects of all sorts, so you can see them early enough to avoid them without making sudden, unsafe moves.
- **Off Ramps/On Ramps.** Freeway and turnpike exits can be particularly dangerous for CMVs. Off and on ramps often have speed limit signs posted. Remember, these speeds may be safe for small vehicles, but may not be safe for larger vehicles or heavily loaded vehicles. Exits that go downhill and turn at the same time can be especially dangerous. The downgrade makes it difficult to reduce speed. Braking and turning at the same time can be a dangerous practice. Make sure you are going slowly enough before you get on the curved part of an off or on ramp.

2.8.3 – Drivers Who Are Hazards

In order to protect yourself and others, you must know when other drivers may do something hazardous. Some clues to this type of hazard are discussed below.

Blocked Vision. People who cannot see others are a very dangerous hazard. Be alert for drivers whose vision is blocked. Vans, loaded station wagons, and small vehicles with the rear window blocked are examples. Rental trucks should be watched carefully. Their drivers are often not used to the limited vision they have to the sides and rear of the truck. In winter, vehicles with frosted, ice-covered, or snow-covered windows are hazards.

Vehicles may be partly hidden by blind intersections or alleys. If you only can see the rear or front end of a vehicle but not the driver, then they cannot see you. Be alert because they may back out or enter into your lane. Always be prepared to stop.

Delivery Trucks Can Present a Hazard. Packages or vehicle doors often block the driver's vision. Drivers of step vans, postal vehicles, and local delivery vehicles are often in a hurry and may suddenly step out of their vehicle or drive their vehicle into the traffic lane.

Parked Vehicles Can Be Hazards. People may start to get out of their vehicles, or they may suddenly start up and drive into your way. Watch for movement inside the vehicle or movement of the vehicle itself that shows people are inside. Watch for brake lights, backup lights, exhaust, and other clues that a driver is about to move.

Be careful of a stopped bus. Passengers may cross in front of or behind the bus, and they often cannot see you.

Pedestrians and Bicyclists Can Also Be Hazards. Walkers, joggers, and bicyclists may be on the road with their back to the traffic, so they cannot see you. Sometimes they wear portable stereos with headsets, so they cannot hear you either. This can be dangerous. On rainy days, pedestrians may not see you because of hats or umbrellas. They may be hurrying out of the rain and may not pay attention to the traffic.

Distractions. People who are distracted are hazards. Watch where they are looking. If they are looking elsewhere, they cannot see you. Be alert even when they are looking at you. They may believe they have the right of way.

Children. Children tend to act quickly without checking traffic. Children playing with one another may not look for traffic and are a serious hazard.

Talkers. Drivers or pedestrians talking to one another may not be paying close attention to the traffic.

Workers. People working on or near the roadway are a hazard clue. The work creates a distraction for other drivers and the workers themselves may not see you.

Ice Cream Trucks. Someone selling ice cream is a hazard clue. Children may be nearby and may not see you.

Disabled Vehicles. Drivers changing a tire or fixing an engine often do not pay attention to the danger roadway traffic is to them. They are often careless. Jacked up wheels or raised hoods are hazard clues.

Accidents. Accidents are particularly hazardous. People involved in the accident may not look for traffic. Passing drivers tend to look at the accident. People often run across the road without looking. Vehicles may slow or stop suddenly.

Shoppers. People in and around shopping areas are often not watching traffic because they are looking for stores or looking into store windows. People often run across the parking lot without looking. Vehicles may slow down or suddenly stop.

Confused Drivers. Confused drivers often change direction suddenly or stop without warning. Confusion is common near freeway or turnpike interchanges and major intersections. Tourists unfamiliar with the area can be very hazardous. Clues to tourists include car-top luggage and out-of-state license plates. Unexpected actions (stopping in the middle of a block, changing lanes for no apparent reason, backup lights suddenly going on) are clues to confusion. Hesitation is another clue, including driving very slowly, using brakes often, or stopping in the middle of an intersection. You may also see drivers who are looking at street signs, maps, and house numbers. These drivers may not be paying attention to you.

Slow Drivers. Motorists who fail to maintain normal speed are hazards. Seeing slow moving vehicles early can prevent an accident. Some vehicles, by their nature, are slow and seeing them is a hazard clue (mopeds, farm machinery, construction machinery, tractors, etc.). Some of these will have the “slow moving vehicle” emblem to warn you. This is a red triangle with an orange center.

Vehicles displaying this emblem are not designed to attain a speed greater than 25 mph (CVC §385.5).

Drivers Signaling a Turn May Be a Hazard. Drivers signaling a turn may slow more than expected or stop. If they are making a tight turn into an alley or driveway, they may go very slowly. If pedestrians or other vehicles block them, they may have to stop on the roadway. Vehicles turning left may have to stop for oncoming vehicles.

Drivers in a Hurry. Drivers may feel your CMV is preventing them from getting where they want to go on time. Such drivers may pass you without a safe gap in the oncoming traffic, cutting too close in front of you. Drivers entering the road may pull in front of you in order to avoid being stuck behind you, causing you to brake. Be aware of this and watch for drivers who are in a hurry.

Impaired Drivers. Drivers who are sleepy, have had too much to drink, are on drugs, or are ill are hazards. Some clues to these drivers are:

- Weaving across the road or drifting from one side to another.
- Leaving the road (dropping right wheels onto the shoulder, or bumping across a curb in a turn).
- Stopping at the wrong time (stopping at a green light, or waiting too long at a stop).
- Open window in cold weather.
- Speeding up or slowing down suddenly and driving too fast or too slow.

Be alert for drunk drivers and sleepy drivers late at night.

Driver Body Movement as a Clue. Drivers look in the direction they are going to turn. You may sometimes get a clue from a driver’s head and body movements that a driver may be going to make a turn, even though the turn signals are not on. Drivers making over-the-shoulder checks may be going to change lanes. These clues are most easily seen in motorcyclists and bicyclists. Watch other road users and try to tell whether they might do something hazardous.

Conflicts. You are in conflict when you have to change speed and/or direction to avoid hitting someone. Conflicts occur at intersections where vehicles meet, at merges (such as turnpike on ramps) and where lane changes are needed (such as the end of a lane, forcing a move to another lane of traffic). Other situations include slow moving or stalled traffic in a traffic lane, and accident scenes. Watch for other drivers who are in conflict because they are a hazard to you. When they react to this conflict, they may do something that will put them in conflict with you.

2.8.4 – Always Have a Plan

You should always be looking for hazards. Continue to learn to see hazards on the road. However, do not forget why you are looking for the hazards—they may turn into emergencies. Look for the hazards to have time to plan a way out of any emergency. When you see a hazard, think about the emergencies that could develop and figure out what you would do. Always be prepared to take action based on your plans. In this way, you will be a prepared, defensive driver who will improve your own safety as well as the safety of all road users.



SUBSECTIONS 2.7 AND 2.8

Test Your Knowledge

1. How do you find out how many seconds of following distance space you have?
2. If you are driving a 30-foot vehicle at 55 mph, how many seconds of following distance should you allow?
3. You should decrease your following distance if somebody is following you too closely. True or False?
4. If you swing wide to the left before turning right, another driver may try to pass you on the right. True or False?
5. What is a hazard?
6. Why make emergency plans when you see a hazard?

These questions may be on the test. If you cannot answer them all, reread Subsections 2.7 and 2.8.



2.9 – DISTRACTED DRIVING

A driver distraction is anything that takes your attention away from driving. Whenever you are driving a vehicle and your full attention is not on the driving task, you are putting yourself, your passengers, other vehicles, and pedestrians in danger. Distracted driving can cause accidents, resulting in injury, death, or property damage.

Activities inside the vehicle that can distract your attention include: talking to passengers; adjusting the radio, CD player or climate controls; eating, drinking, smoking; reading maps or other literature; picking up something that fell; talking on a cell phone or citizens band (CB) radio; reading or sending text messages; using any type of telematics or electronic devices (such as navigation systems, pagers, personal digital assistant, computers, etc.); daydreaming or being occupied with other mental distractions; and many others.

Possible distractions that could occur outside a moving vehicle: traffic, vehicles, or pedestrians; events such as police pulling someone over, an accident scene or road construction; sunlight/sunset; objects in roadway; reading billboards or other road advertisements; and many others.

2.9.1 – The Distracted Driving Crash Problem

The Large Truck Crash Causation Study (LTCCS) reported that 8 percent of large-truck accidents occurred when CMV drivers were externally distracted and 2 percent of large-truck accidents occurred when the driver was internally distracted.

Approximately 5,500 people are killed each year on U.S. roadways and an estimated 448,000 are injured in motor vehicle accidents involving distracted driving (National Highway Traffic Safety Administration [NHTSA] Traffic Safety Facts: Distracted Driving).

Research indicates that the burden of talking on a cell phone—even if it is hands-free—saps the brain of 39 percent of the energy it would ordinarily devote to safe driving. Drivers who use a hand-held device are more likely to get into an accident serious enough to cause injury. (For more information, visit the NHTSA Distracted Driving web page at distraction.gov.)

2.9.2 – Effects of Distracted Driving

Effects of distracted driving include slowed perception, which may cause you to be delayed in perceiving or completely fail to perceive an important traffic event. Delayed decision making and improper action can cause you to be delayed in taking the proper action or make incorrect inputs to the steering, accelerator, or brakes.

2.9.3 – Types of Distractions

There are many causes of distraction, all with the potential to increase risk.

- **Physical Distraction**—causes you to take your hands off the wheel or eyes off the road, such as reaching for an object.
- **Mental Distraction**—takes your mind away from the road, such as engaging in conversation with a passenger or thinking about something that happened during the day.
- **Both Physical and Mental Distraction**—creates an even greater chance an accident could happen, such as talking on a cell phone, or sending or reading text messages.

2.9.4 – Cell/Mobile Phones

CFR, Title 49, Part 383, 384, 390, 391, and 392 of the *Hazardous Materials Regulations* (HMR) restricts the use of hand-held mobile telephones by drivers of CMVs and implements new driver disqualification sanctions for drivers of CMVs who fail to comply with this federal restriction, or have multiple convictions for violating a state or local law or ordinance on motor vehicle traffic control that restricts the use of hand-held mobile telephones. Additionally, motor carriers are prohibited from requiring or allowing drivers of CMVs to use hand-held mobile telephones.

The use of hand-held mobile telephones means using at least one hand to hold a mobile telephone to conduct a voice communication; dialing a mobile telephone by pressing more than a single button; or moving from a seated driving position while restrained by a seat belt to reach for a mobile telephone. If you choose to use a mobile phone while operating a CMV, you may only use a hands-free mobile phone that is located close to you and can be operated in compliance with the rule to conduct a voice communication.

Your CDL will be disqualified after 2 or more convictions of any state law on hand-held mobile telephone use while operating a CMV. Disqualification is 60 days for the second offense within 3 years and 120 days for 3 or more offenses within 3 years. In addition, the first and each subsequent violation of such a prohibition are subject to civil penalties imposed on such drivers. Motor carriers must not allow nor require drivers to use a hand-held mobile telephone while driving. Employers may also be subject to civil penalties. There is an emergency exception that allows you to use your hand-held mobile telephone if necessary to communicate with law enforcement officials or other emergency services.

Research shows the odds of being involved in a safety-critical event (for example, accident, near-accident, or unintentional lane deviation) is 6 times greater for CMV drivers who engage in dialing a mobile telephone while driving than for those who do not. Dialing drivers took their eyes off the forward roadway for an average of 3.8 seconds. At 55 mph (or 80.7 feet per second), this equates to a driver traveling 306 feet (approximate length of an American football field) without looking at the roadway.

Your primary responsibility is to operate a motor vehicle safely. To do this, you must focus your full attention on the driving task.

Note that hands-free devices are no less likely than hand-held cell phones to cause you to become distracted. Attention is diverted from the driving task while using either device.

In California, you are not allowed to use an electronic device while driving unless it is hands-free. Even these devices are unsafe to use when you are driving down the road.

If you must use your electronic communication device while driving, follow these tips:

- Try to keep it brief and never use the electronic device for social visiting.
- Hang up your cell phone in difficult traffic situations.
- Do not use the vehicle's equipment or any electronic communication device when approaching locations with heavy traffic, road construction, heavy pedestrian traffic, or severe weather conditions.
- Do not attempt to type or read messages.

2.9.5 – Texting

CFR, Title 49, Part 383, 384, 390, 391, 392, and the FMCSR prohibits texting by CMV drivers while operating in interstate commerce, and implements new driver disqualification sanctions for drivers of CMVs who fail to comply with this federal prohibition, or who have multiple convictions for violating a state or local law or ordinance on motor vehicle traffic control that prohibits texting while driving. Additionally, motor carriers are prohibited from requiring or allowing their drivers to engage in texting while driving.

Texting means manually entering text into, or reading text from, an electronic device. This includes, but is not limited to, short message service, emailing, instant messaging, a command or request to access a webpage or engaging in any other form of electronic text retrieval or entry, for present or future communication.

Electronic device includes, but is not limited to, a cellular telephone, personal digital assistant, pager, computer, or any other device used to enter, write, send, receive, or read text.

Your CDL will be disqualified after 2 or more convictions of any state law on texting while operating a CMV. Disqualification is 60 days for the second offense within 3 years and 120 days for 3 or more offenses within 3 years. In addition, the first and each subsequent violation of such a prohibition are subject to civil penalties imposed on such drivers, in an amount up to \$2,750. No motor carrier shall allow or require its drivers to engage in texting while driving. There is an emergency exception that allows you to text if necessary to communicate with law enforcement officials or other emergency services.

Evidence suggests text messaging is even riskier than talking on a cell phone because it requires you to look at a small screen and manipulate the keypad with your hands. Texting is the most alarming distraction because it involves both physical and mental distraction simultaneously.

Research shows that the odds of being involved in a safety-critical event (such as an accident, near-accident, unintentional lane deviation) is 23.2 times greater for CMV drivers who engage in texting while driving than for those who do not. Sending or receiving text takes your eyes from the road for an average of 4.6 seconds. At 55 mph, you would travel 371 feet (the length of an entire American football field) without looking at the roadway.

2.9.6 – Do Not Drive Distracted

Your goal should be to eliminate all in-vehicle distractions before driving begins. Accomplishing this goal can be done by:

- Assessing all potential in-vehicle distractions before driving.
- Developing a preventative plan to reduce/eliminate possible distractions.
- Expecting distractions to occur.
- Discussing possible scenarios before getting behind the wheel.

Based on the assessment of potential distractions, you can formulate a preventative plan to reduce/eliminate possible distractions.

If drivers react a half-second slower because of distractions, accidents double. Some tips to follow so you will not become distracted:

- Turn off all communication devices.
- If you must use a mobile phone, make sure it is within close proximity that it is operable while you are restrained, use an earpiece or the speaker phone function, use voice-activated dialing, and use the hands-free feature. Drivers are **not** in compliance if they unsafely reach for a mobile phone, even if they intend to use the hands-free function.

- Do not type or read a text message on a mobile device while driving.
- Familiarize yourself with your vehicle's features and equipment before you get behind the wheel.
- Adjust all vehicle controls and mirrors to your preferences prior to driving.
- Preprogram radio stations and preload your favorite CDs.
- Clear the vehicle of any unnecessary objects and secure cargo.
- Review maps, program the GPS, and plan your route before you begin driving.
- Do not attempt to read or write while you drive.
- Avoid smoking, eating, and drinking while you drive. Leave early to allow yourself time to stop to eat.
- Do not engage in complex or emotionally intense conversations with other occupants.
- Secure commitment from other occupants to behave responsibly and support the driver in reducing distractions.

2.9.7 – Watch Out for Other Distracted Drivers

You need to be able to recognize other drivers who are engaged in any form of driving distraction. Not recognizing other distracted drivers can prevent you from perceiving or reacting correctly in time to prevent an accident. Watch for:

- Vehicles that may drift over the lane divider lines or within their own lane.
- Vehicles traveling at inconsistent speeds.
- Drivers who are preoccupied with maps, food, cigarettes, cell phones, or other objects.
- Drivers who appear to be involved in conversations with their passengers.

Give a distracted driver plenty of room and maintain your safe following distance.

Be very careful when passing a driver who seems to be distracted. That driver may not be aware of your presence, and they may drift in front of you.

2.10 – AGGRESSIVE DRIVERS/ROAD RAGE

2.10.1 – What Is It?

Aggressive driving and road rage is not a new problem. However, in today's world, where heavy and slow-moving traffic and tight schedules are the norm, more and more drivers are taking out their anger and frustration in their vehicles.

Crowded roads leave little room for error, leading to suspicion and hostility among drivers and encouraging them to take personally the mistakes of other drivers.

Aggressive driving is the act of operating a motor vehicle in a selfish, bold, or pushy manner, without regard for the rights or safety of others. One sign of an aggressive driver is a driver changing lanes frequently and abruptly without notice.

Road rage is operating a motor vehicle with the intent of doing harm to others or physically assaulting a driver or their vehicle.

2.10.2 – Do Not Be an Aggressive Driver

- How you feel before you start your vehicle has a lot to do with how stress will affect you while driving.
- Reduce your stress before and while you drive. Listen to "easy listening" music.
- Give the drive your full attention. Do not allow yourself to become distracted by talking on your cell phone, eating, etc.
- Be realistic about your travel time. Expect delays because of traffic, construction, or bad weather, and make allowances.
- If you are going to be later than you expected—deal with it. Take a deep breath and accept the delay.
- Give other drivers the benefit of the doubt. Try to imagine why he or she is driving that way. Whatever their reason, it has nothing to do with you.
- Slow down and keep your following distance reasonable.

- Do not drive slowly in the left lane of traffic.
- Avoid gestures. Keep your hands on the wheel. Avoid making any gestures that might anger another driver, even seemingly harmless expressions of irritation like shaking your head.
- Be a cautious and courteous driver. If another driver seems eager to get in front of you, say, “Be my guest.” This response will soon become a habit and you will not be as offended by other drivers’ actions.

2.10.3 – What You Should Do When Confronted by an Aggressive Driver

- First and foremost, make every attempt to get out of their way.
- Put aside your pride. Do not challenge them by speeding up or attempting to hold-your-own in your travel lane.
- Avoid eye contact.
- Ignore gestures and refuse to react to them.
- Report aggressive drivers to the appropriate authorities by providing a vehicle description, license number, location and, if possible, direction of travel.
- If you have a cell phone and can use it safely, call the police.
- If an aggressive driver is involved in an accident farther down the road, stop a safe distance from the accident scene, wait for the police to arrive, and report the driving behavior you witnessed.

SUBSECTIONS 2.9 AND 2.10

Test Your Knowledge

1. What are some tips to follow so you will not become a distracted driver?
2. How do you use in-vehicle communications equipment cautiously?
3. How do you recognize a distracted driver?
4. What is the difference between aggressive driving and road rage?
5. What should you do when confronted with an aggressive driver?
6. What are some things you can do to reduce your stress before and while you drive?

These questions may be on the test. If you cannot answer them all, reread Subsections 2.9 and 2.10.

2.11 – DRIVING AT NIGHT

2.11.1 – It Is More Dangerous

You are at greater risk when you drive at night. Drivers cannot see hazards as quickly as in daylight, so they have less time to respond. Drivers caught by surprise are less able to avoid an accident. The problems of night driving involve the driver, roadway, and vehicle.

2.11.2 – Driver Factors

Vision. Good vision is critical for safe driving. Your control of the brake, accelerator, and steering wheel is based on what you see. If you cannot see clearly, you will have trouble identifying traffic and roadway conditions, spotting potential trouble or responding to problems in a timely manner.

Because seeing well is so critical to safe driving, you should have your eyes checked regularly by an eye specialist. You may never know you have poor vision unless your eyes are tested. If you need to wear glasses or contact lenses for driving, remember to:

- Always wear them when driving, even if driving short distances. If your DL has a corrective lenses restriction, it is illegal to move a vehicle without using corrective lenses.
- Keep an extra set of corrective lenses in your vehicle. If your normal corrective lenses are broken or lost, you can use the spare lenses to drive safely.
- Avoid using dark or tinted corrective lenses at night, even if you think they help with glare. Tinted lenses cut down the light that you need to see clearly under night driving conditions.

Glare. Drivers can be blinded for a short time by bright light. It can take several seconds to recover from glare. Even 2 seconds of glare blindness can be dangerous. A vehicle going 55 mph will travel more than half the distance of an American football field during that time.

Fatigue and Lack of Alertness. Fatigue is physical or mental tiredness that can be caused by physical or mental strain, repetitive tasks, illness, or lack of sleep. Just like alcohol and drugs, it impairs your vision and judgment. Fatigue causes errors related to speed and distance, increases your risk of being in an accident, causes you to not see and react to hazards as quickly, and affects your ability to make critical decisions. When you are fatigued, you could fall asleep behind the wheel and crash, injuring or killing yourself or others.

Fatigued or drowsy driving is one of the leading causes of traffic accidents. NHTSA estimates that 100,000 police-reported accidents a year are the result of drowsy driving. According to the National Sleep Foundation's Sleep in America Poll, 60 percent of Americans have driven while feeling sleepy and more than 1/3 (36 percent or 103 million people) admit to having actually fallen asleep at the wheel. Drivers may experience short bursts of sleep lasting only a few seconds or fall asleep for longer periods of time. Either way, the chance of an accident increases dramatically.

At-Risk Groups

The risk of having an accident due to drowsy driving is not uniformly distributed across the population. Accidents tend to occur at times when sleepiness is most pronounced, for example, during the night and in the mid-afternoon. Most people are less alert at night, especially after midnight. This is particularly true if you have been driving for a long time. Thus, individuals who drive at night are more likely to have fall-asleep accidents.

Research has identified young males, shift workers, commercial drivers, especially long-haul drivers, and people with untreated sleep disorders or with short-term or chronic sleep deprivation as being at increased risk for having a fall-asleep accident. At least 15 percent of all heavy truck accidents involve fatigue.

A congressionally mandated study of 80 long-haul truck drivers in the U.S. and Canada found drivers averaged less than 5 hours of sleep per day (FMLSA, 1996). It is no surprise that the National Transportation Safety Board (NTSB) reported that drowsy driving was probably the cause of more than half of accidents leading to a truck driver's death (NTSB, 1990). For each truck driver fatality, another 3 to 4 people are killed (NHTSA, 1994).

Warning Signs of Fatigue

Many people cannot tell if or when they are about to fall asleep. Here are some signs that should tell you to stop and rest:

- Difficulty focusing, frequent blinking, or heavy eyelids.
- Yawning repeatedly or rubbing eyes.
- Daydreaming and wandering/disconnected thoughts.
- Trouble remembering the last few miles driven and missing exits or traffic signs.
- Trouble keeping head up.
- Drifting from your lane, following too closely, or hitting a shoulder rumble strip.
- Feeling restless and irritable.

When you are tired, trying to "push on" is far more dangerous than most drivers think. It is a major cause of fatal accidents. If you notice any signs of fatigue, stop driving and go to sleep for the night or take a 15–20 minute nap.

Are You at Risk?

Before you drive, consider whether you are:

- Sleep-deprived or fatigued (6 hours of sleep or less triples your risk).
- Suffering from sleep loss (insomnia), poor quality sleep, or sleep deprivation.
- Driving long distances without proper rest breaks.
- Driving through the night, mid-afternoon, or when you would normally be asleep. Many heavy motor vehicle accidents occur between midnight and 6 a.m.
- Taking sedating medications (antidepressants, cold tablets, antihistamines).
- Working more than 60 hours a week (increases your risk by 40 percent).
- Working more than one job and your main job involves shift work.
- Driving alone or on a long, rural, dark, or boring road.
- Flying and changing time zone.

Preventing Drowsiness Before a Trip:

- Get adequate sleep—adults need 8–9 hours to maintain alertness.
- Prepare route carefully to identify total distance, stopping points, and other logistic considerations.
- Schedule trips for the hours you are normally awake, not the middle of the night.
- Drive with a passenger.
- Avoid medications that cause drowsiness.
- Consult your physician if you suffer from daytime sleepiness, have difficulty sleeping at night, or take frequent naps.
- Incorporate exercise into your daily life to give you more energy.

Maintaining Alertness While Driving:

- Protect yourself from glare and eyestrain with sunglasses.
- Keep cool by opening the window or using the air conditioner.
- Avoid heavy foods.
- Be aware of down time during the day.
- Have another person ride with you, and take turns driving.
- Take periodic breaks – about every 100 miles or 2 hours during long trips.
- Stop driving and rest or take a nap.
- Caffeine consumption can increase awareness for a few hours, but do not drink too much. It will eventually wear off. Do not rely on caffeine to prevent fatigue.
- Avoid drugs. While they may keep you awake for a while, they will not make you alert.

If you are drowsy, the only safe cure is to get off the road and sleep. If you do not, you risk your life and the lives of others.

2.11.3 – Roadway Factors

Poor Lighting. In the daytime there is usually enough light to see well. This is not true at night. Some areas may have bright street lights, but many areas will have poor lighting. On most roads you will probably have to depend entirely on your headlights.

Less light means you will not be able to see hazards as well as in daytime. Road users who do not have lights are hard to see. There are many accidents at night involving pedestrians, bicyclists, and animals.

Even when there are lights, the road scene can be confusing. Traffic signals and hazards can be hard to see against a background of signs, shop windows, and other lights.

Drive slower when lighting is poor or confusing.

Drive slowly enough to be sure you can stop in the distance you can see ahead.

Drunk Drivers. Drunk drivers and drivers under the influence of drugs are a hazard to themselves and to you. Be especially alert around the closing times of bars and taverns. Watch for drivers who have trouble staying in their lane, or maintaining speed, stop without reason, or show other signs of being under the influence of alcohol or drugs.

2.11.4 – Vehicle Factors

Headlights. At night, your headlights will usually be the main source of light for you to see by and for others to see you. You cannot see nearly as much with your headlights as you see in the daytime. With low beams you can see ahead about 250 feet and with high beams about 350–500 feet. You must adjust your speed to keep your stopping distance within your sight distance. This means going slowly enough to be able to stop within the range of your headlights. Otherwise, by the time you see a hazard; you will not have time to stop.

Night driving can be more dangerous if you have problems with your headlights. Dirty headlights may give only half the light they should. This cuts down your ability to see, and makes it harder for others to see you. Make sure your lights are clean and working. Headlights can be out of adjustment. If they do not point in the right direction, they will not give you a good view and can blind other drivers. Have a qualified person make sure they are adjusted properly.

You must turn on your headlights:

- A half hour after sunset to a half hour before sunrise.
- If snow, rain, fog, or other hazardous weather condition require the use of windshield wipers.
- When visibility is not sufficient to clearly see a person or a vehicle for a distance of 1,000 feet (CVC §§280 and 24400).

No vehicle may be driven with only parking lights on. However, they may be used as signals or when the headlamps are also lighted (CVC §24800).

Other Lights. In order for you to be seen easily, the following must be clean and working properly:

- Reflectors
- Marker lights
- Clearance lights
- Taillights
- Identification lights

Turn Signals and Brake Lights. At night your turn signals and brake lights are even more important for telling other drivers what you intend to do. Make sure you have clean, working turn signals and brake lights.

Windshield and Mirrors. It is more important at night than in the daytime to have a clean windshield and clean mirrors. Bright lights at night can cause dirt on your windshield or mirrors to create a glare of its own, blocking your view. Most people have experienced driving toward the sun just as it has risen or is about to set, and found that they can barely see through a windshield that seemed to look okay in the middle of the day. Clean your windshield on the inside and outside for safe driving at night.

2.11.5 – Night Driving Procedures

Vehicle Procedures. Make sure you are rested and alert. If you are drowsy, sleep before you drive! Even a nap can save your life or the lives of others. If you wear eyeglasses, make sure they are clean and unscratched. Do not wear sunglasses at night. Do a complete vehicle inspection. Pay attention to checking all lights and reflectors, and cleaning those you can reach.

Avoid Blinding Others. Glare from your headlights can cause problems for drivers coming toward you. They can also bother drivers going in the same direction you are, when your lights shine in their rearview mirrors. Dim your lights before they cause glare for other drivers. Dim your lights within 500 feet of an oncoming vehicle and when following another vehicle within 500 feet.

Avoid Glare From Oncoming Vehicles. Do not look directly at lights of oncoming vehicles. Look slightly to the right at a right lane or edge marking, if available. If other drivers do not put their low beams on, do not try to “get back at them” by putting your own high beams on. This increases glare for oncoming drivers and increases the chance of an accident.

Use High Beams When you Can. Some drivers make the mistake of always using low beams. This seriously cuts down on their ability to see ahead. Use high beams when it is safe and legal to do so. Use them when you are not within 500 feet of an approaching vehicle. Also, do not let the inside of your cab get too bright. This makes it harder to see outside. Keep the interior light off, and adjust your instrument lights as low as you can to still be able to read the gauges.

If You Get Sleepy, Stop at the Nearest Safe Place. People often do not realize how close they are to falling asleep even when their eyelids are falling shut. If you can safely do so, look at yourself in a mirror. If you look sleepy, or just feel sleepy, stop driving! You are in a very dangerous condition. The only safe cure is to sleep.

2.12 – DRIVING IN FOG

Fog can occur at any time. Fog on highways can be extremely dangerous. Fog is often unexpected, and visibility can deteriorate rapidly. You should watch for foggy conditions and be ready to reduce your speed. Do not assume the fog will thin out after you enter it.

The best advice for driving in fog is do not. It is preferable that you pull off the road into a rest area or truck stop until visibility is better. If you must drive, be sure to consider the following:

- Obey all fog-related warning signs.
- Slow down before you enter fog.
- Use low-beam headlights and fog lights for best visibility even in daytime, and be alert for other drivers who may have forgotten to turn on their lights.
- Turn on your 4-way emergency flashers. This will give vehicles approaching you from behind a better opportunity to notice your vehicle.
- Watch for vehicles on the side of the roadway. Seeing taillights or headlights in front of you may not be a true indication of where the road is ahead of you. The vehicle may not be on the road at all.
- Use roadside highway reflectors as guides to determine how the road may curve ahead of you.
- Listen for traffic you cannot see.
- Avoid passing other vehicles.
- Do not stop along the side of the road, unless absolutely necessary.

2.13 – DRIVING IN WINTER

2.13.1 – Vehicle Checks

Make sure your vehicle is ready before driving in winter weather. You should make a regular vehicle inspection, paying extra attention to the following items:

Coolant Level and Antifreeze Amount. Make sure the cooling system is full and there is enough antifreeze in the system to protect against freezing. This can be checked with a special coolant tester.

Defrosting and Heating Equipment. Make sure the defrosters work. They are needed for safe driving. Make sure the heater is working, and that you know how to operate it. If you use other heaters and expect to need them (such as, mirror heaters, battery box heaters, or fuel tank heaters), check their operation.

Wipers and Washers. Make sure the windshield wiper blades are in good condition. Make sure the wiper blades press against the window hard enough to wipe the windshield clean, otherwise they may not sweep off snow properly. Make sure the windshield washer works and there is washing fluid in the washer reservoir.

Use windshield washer antifreeze to prevent freezing of the washer liquid. If you cannot see well enough while driving (for example, if your wipers fail), stop safely and fix the problem.

Tires. Make sure you have enough tread on your tires. The drive tires must provide traction to push the rig over wet pavement and through snow. The steering tires must have traction to steer the vehicle. Enough tread is especially important in winter conditions. You must have at least 4/32 inch tread depth in every major groove on front tires and at least 2/32 inch on other tires. More would be better. Use a gauge to determine if you have enough tread for safe driving.

Tire Chains. You may find yourself in conditions where you cannot drive without chains, even to get to a place of safety. Carry the right number of chains and extra cross-links. Make sure they will fit your drive tires. Check the chains for broken hooks, worn or broken cross-links, and bent or broken side chains. Learn how to put the chains on before you need to do it in snow and ice.

Lights and Reflectors. Make sure the lights and reflectors are clean. Lights and reflectors are especially important during bad weather. Check from time to time during bad weather to make sure they are clean and working properly.

Windows and Mirrors. Remove any ice, snow, etc., from the windshield, windows, and mirrors before starting. Use a windshield scraper, snow brush, and windshield defroster as necessary.

Hand Holds, Steps, and Deck Plates. Remove all ice and snow from hand holds, steps, and deck plates. This will reduce the danger of slipping.

Radiator Shutters and Winterfront. Remove ice from the radiator shutters. Make sure the winterfront is not closed too tightly. If the shutters freeze shut or the winterfront is closed too much, the engine may overheat and stop.

Exhaust System. Exhaust system leaks are especially dangerous when cab ventilation may be poor (windows rolled up, etc.). Loose connections could permit poisonous carbon monoxide to leak into your vehicle. Carbon monoxide gas will cause you to be sleepy. In large enough amounts, it can kill you. Check the exhaust system for loose parts and for sounds and signs of leaks.

2.13.2 – Driving on Slippery Surfaces

Slippery Surfaces. Drive slowly and smoothly on slippery roads. If it is very slippery, you should not drive at all. Stop at the first safe place.

- **Start Gently and Slowly.** When first starting, get the feel of the road. Do not hurry.
- **Check for Ice.** Check for ice on the road, especially bridges and overpasses. A lack of spray from other vehicles indicates ice has formed on the road. Also, check your mirrors and wiper blades for ice. If they have ice, the road most likely will be icy as well.
- **Adjust Turning and Braking to Conditions.** Make turns as gently as possible. Do not brake any harder than necessary, and do not use the engine brake or speed retarder. (They can cause the driving wheels to skid on slippery surfaces.)

- **Adjust Speed to Conditions.** Do not pass slower vehicles unless necessary. Go slowly and watch far enough ahead to keep a steady speed. Avoid having to slow down and speed up. Take curves at slower speeds and do not brake while in curves. Be aware that as the temperature rises to the point where ice begins to melt, the road becomes even more slippery. Slow down more.
- **Adjust Space to Conditions.** Do not drive alongside other vehicles. Keep a longer following distance. When you see a traffic jam ahead, slow down or stop to wait for it to clear. Try hard to anticipate stops early and slow down gradually. Watch for snowplows, as well as salt and sand trucks, and give them plenty of room.

Wet Brakes. When driving in heavy rain or deep standing water, your brakes will get wet. Water in the brakes can cause the brakes to be weak, apply unevenly, or grab. This can cause lack of braking power, wheel lockups, pulling to one side or the other, and jackknife if you pull a trailer.

Avoid driving through deep puddles or flowing water if possible. If not, you should:

- Slow down and place transmission in a low gear.
- Gently put on the brakes. This presses linings against brake drums or discs and keeps mud, silt, sand, and water from getting in.
- Increase engine rpm and cross the water while keeping light pressure on the brakes.
- Maintain light pressure on the brakes for a short distance to heat them up and dry them out when out of the water.
- Make a test stop when safe to do so. Check behind to make sure no one is following, and then apply the brakes to be sure they work well. If not, dry them out further as described above. (**Caution:** Do not apply too much brake pressure and accelerator at the same time because you can overheat brake drums and linings.)

2.14 – DRIVING IN VERY HOT WEATHER

2.14.1 – Vehicle Checks

Do a normal vehicle inspection, but pay special attention to the following items.

Tires. Check the tire mounting and air pressure. Inspect the tires every 2 hours or every 100 miles when driving in very hot weather. Air pressure increases with temperature. Do not let air out or the pressure will be too low when the tires cool off. If a tire is too hot to touch, remain stopped until the tire cools off. Otherwise, the tire may blow out or catch fire.

Engine Oil. The engine oil helps keep the engine cool, as well as lubricate it. Make sure there is enough engine oil. If you have an oil temperature gauge, make sure the temperature is within the proper range while you are driving.

Engine Coolant. Before starting out, make sure the engine cooling system has enough water and antifreeze according to the engine manufacturer’s directions. (Antifreeze helps the engine under hot conditions as well as cold conditions.) When driving, check the water temperature or coolant temperature gauge from time to time. Make sure it remains in the normal range. If the gauge goes above the highest safe temperature, there may be something wrong that could lead to engine failure and possibly fire. Stop driving as soon as safely possible and try to find out what is wrong.

Some vehicles have sight glasses, see-through coolant overflow containers, or coolant recovery containers. These permit you to check the coolant level while the engine is hot. If the container is not part of the pressurized system, the cap can be safely removed and coolant added even when the engine is at operating temperature.

Never remove the radiator cap or any part of the pressurized system until the system has cooled. Steam and boiling water can spray under pressure and cause severe burns. If you can touch the radiator cap with your bare hand, it is probably cool enough to open. If coolant has to be added to a system without a recovery tank or overflow tank, follow these steps:

- Shut the engine off.
- Wait until the engine has cooled.
- Protect your hands (use gloves or a thick cloth).
- Turn the radiator cap slowly to the first stop, which releases the pressure seal.

- Step back while pressure is released from cooling system.
- When all pressure has been released, press down on the cap and turn it further to remove it.
- Visually check the level of coolant and add more coolant if necessary.
- Replace the cap and turn it all the way to the closed position.

Engine Belts. Learn how to check v-belt tightness on your vehicle by pressing on the belts. Loose belts will not turn the water pump and/or fan properly. This will result in overheating. Also, check belts for cracking or other signs of wear.

Hoses. Make sure coolant hoses are in good condition. A broken hose while driving can lead to engine failure and even fire.

2.14.2 – Driving in the Heat

Watch for Bleeding Tar. Tar in the road pavement frequently rises to the surface in very hot weather. Spots where tar “bleeds” to the surface are very slippery.

Go Slowly Enough to Prevent Overheating. High speeds create more heat for the tires and engine. In desert conditions, the heat may build up to the point where it is dangerous. The heat will increase chances of tire failure or even fire, and engine failure.

////////////////////////////////////

SUBSECTIONS 2.11, 2.12, 2.13, AND 2.14

Test Your Knowledge

1. You should use low beams whenever you can. True or False?
2. What should you do before you drive if you are drowsy?
3. What effects can wet brakes cause? How can you avoid these problems?
4. You should let air out of hot tires so the pressure goes back to normal. True or False?
5. You can safely remove the radiator cap as long as the engine is not overheated. True or False?

These questions may be on the test. If you cannot answer all of them, reread Subsections 2.11, 2.12, 2.13, and 2.14.

////////////////////////////////////

2.15 – RAILROAD-HIGHWAY CROSSINGS

Railroad-highway grade crossings are a special kind of intersection where the roadway crosses train tracks. These crossings are always dangerous. Every such crossing must be approached with the expectation that a train is coming. It is extremely difficult to judge the distance of the train from the crossing, as well as the speed of an approaching train.

2.15.1 – Types of Crossings

Passive Crossings. This type of crossing does not have any type of traffic control device. The decision to stop or proceed rests entirely in your hands. Passive crossings require you to recognize the crossing, search for any train using the tracks and decide if there is sufficient clear space to cross safely.

Active Crossings. This type of crossing has a traffic control device installed at the crossing to regulate traffic at the crossing. These active devices include flashing red lights (with or without bells) and flashing red lights with bells and gates.

2.15.2 – Warning Signs and Devices

Advance Warning Signs. The round, black-on-yellow warning sign is placed ahead of a public railroad-highway crossing. The advance warning sign tells you to slow down, look, and listen for the train, and be prepared to stop at the tracks if a train is coming. All passenger and HazMat carrying vehicles are required to stop. See Figure 2.15.



Figure 2.15

Pavement Markings. Pavement markings mean the same as advance warning sign. They consist of an “X” with the letters “RR” and a no-passing marking on 2-lane roads. See Figure 2.16.

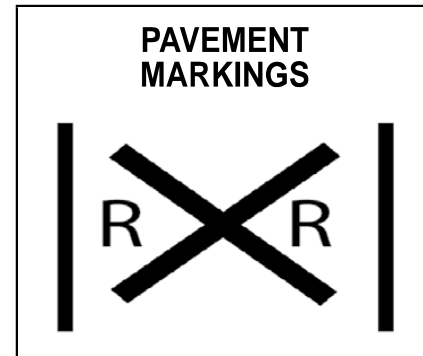

Figure 2.16

There is also a no passing zone sign on 2-lane roads. There may be a white stop line painted on the pavement before the railroad tracks. The front of the school bus must remain behind this line while stopped at the crossing.

Crossbuck Signs. This sign marks the grade crossing. It requires you to yield the right-of-way to the train. If there is no white stop line painted on the pavement, vehicles that are required to stop must stop no closer than 15 feet or more than 50 feet from the nearest rail of the nearest track. When the road crosses over more than 1 track, a sign below the crossbuck indicates the number of tracks. See Figure 2.17.

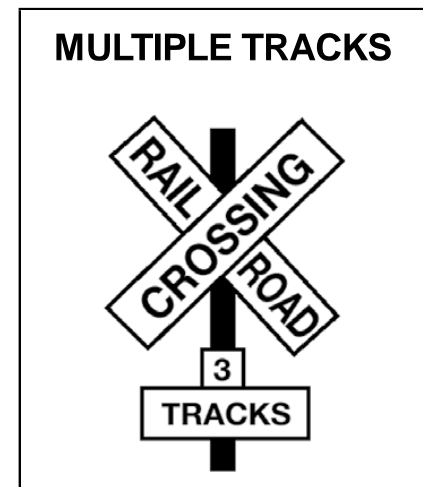

Figure 2.17

Flashing Red Light Signals. At many railroad/highway grade crossings, the crossbuck sign has flashing red lights and bells. When the lights begin to flash, stop! A train is approaching. You are required to yield the right-of-way to the train. If there is more than 1 track, make sure all tracks are clear before crossing. See Figure 2.18.

Gates. Many railroad-highway crossings have gates with flashing red lights and bells. Stop when the lights begin to flash and before the gate lowers across the road lane. Remain stopped until the gates go up and the lights have stopped flashing. Proceed when it is safe. See Figure 2.18.

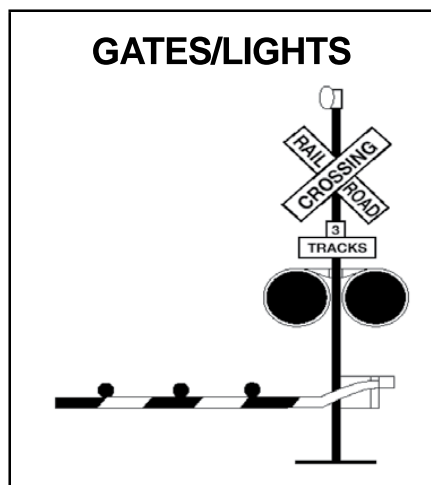

Figure 2.18

2.15.3 – Driving Procedures

Never Race a Train to a Crossing. Never attempt to race a train to a crossing. It is extremely difficult to judge the speed of an approaching train.

Reduce Speed. Speed must be reduced in accordance with your ability to see approaching trains in any direction, and speed must be held to a point which will permit you to stop short of the tracks in case a stop is necessary.

Do Not Expect to Hear a Train. Trains may not or are prohibited from sounding horns when approaching some crossings. Public crossings where trains do not sound horns should be identified by signs. Noise inside your vehicle may also prevent you from hearing the train horn until the train is dangerously close to the crossing.

Do Not Rely on Signals. You should not rely solely upon the presence of warning signals, gates, or flagmen to warn of the approach of trains. Be especially alert at crossings that do not have gates or flashing red light signals.

Double Tracks Require a Double Check. Remember that a train on 1 track may hide a train on the other track. Look both ways before crossing. After 1 train has cleared a crossing, be sure no other trains are near before starting across the tracks.

Yard Areas and Grade Crossings in Cities and Towns. Yard areas and grade crossings in cities and towns are just as dangerous as rural grade crossings. Approach them with as much caution.

2.15.4 – Stopping Safely at Railroad-Highway Crossings

A full stop is required at grade crossings whenever:

- The nature of the cargo makes a stop mandatory under state or federal regulations.
- Such a stop is otherwise required by law.

When stopping be sure to:

- Check for traffic behind you while stopping gradually. Use a pullout lane, if available.
- Turn on your 4-way emergency flashers.

2.15.5 – Crossing the Tracks

Railroad crossings with steep approaches can cause your unit to hang up on the tracks.

Never permit traffic conditions to trap you in a position where you have to stop on the tracks. Be sure you can get all the way across the tracks before you start across. It takes a typical tractor-trailer unit at least 14 seconds to clear a single track and more than 15 seconds to clear a double track.

Do not shift gears while crossing railroad tracks.

2.15.6 – Special Situations

Be Aware! These trailers can get stuck on raised crossings:

- Low slung units (lowboy, car carrier, moving van, or possum-belly livestock trailer).
- Single-axle tractor pulling a long trailer with its landing gear set to accommodate a tandem-axle tractor.

If for any reason you get stuck on the tracks, get out of the vehicle and away from the tracks. Check signposts or signal housing at the crossing for emergency

notification information. Call 9-1-1 or other emergency number. Give the location of the crossing using all identifiable landmarks, especially the DOT number, if posted.

2.16 – MOUNTAIN DRIVING

In mountain driving, gravity plays a major role. On any upgrade, gravity slows you down. The steeper the grade, the longer the grade, and/or the heavier the load, the more you will have to use lower gears to climb hills or mountains. In coming down long, steep downgrades, gravity causes the speed of your vehicle to increase. You must select an appropriate safe speed, and then use a low gear, and proper braking techniques. You should plan ahead and obtain information about any long, steep grades along your planned route of travel. If possible, talk to other drivers who are familiar with the grades to find out what speeds are safe.

You must go slowly enough so your brakes can hold you back without getting too hot. If the brakes become too hot, they may start to “fade.” This means you have to apply them harder and harder to get the same stopping power. If you continue to use the brakes hard, they can keep fading until you cannot slow down or stop at all.

2.16.1 – Select a “Safe” Speed

Your most important consideration is to select a speed that is not too fast for the:

- Total weight of the vehicle and cargo.
- Length of the grade.
- Steepness of the grade.
- Road conditions.
- Weather.

If a speed limit is posted, or there is a sign indicating “Maximum Safe Speed,” never exceed the speed shown. Also, look for and heed warning signs indicating the length and steepness of the grade.

You must use the braking effect of the engine as the principal way of controlling your speed. The braking effect of the engine is greatest when it is near the governed rpms and the transmission is in the lower gears. Save your brakes so you will be able to slow or stop as required by road and traffic conditions.

2.16.2 – Select the Right Gear Before Starting Down the Grade

Shift the transmission to a low gear before starting down the grade. Do not try to downshift after your speed has already built up. You will not be able to shift into a lower gear. You may not even be able to get back into any gear and all engine braking effect will be lost. Forcing an automatic transmission into a lower gear at high speed could damage the transmission and also lead to loss of all engine braking effect.

With older trucks, a rule for choosing gears is to use the same gear going down a hill that you would need to climb the hill. However, new trucks have low friction parts and streamlined shapes for fuel economy. They may also have more powerful engines. This means they can go up hills in higher gears and have less friction and air drag to hold them back going down hills. For that reason, drivers of modern trucks may have to use lower gears going down a hill than required to go up the hill. You should know what is right for your vehicle.

2.16.3 – Brake Fading or Failure

Brakes are designed so brake shoes or pads rub against the brake drum or disks to slow the vehicle. Braking creates heat, but brakes are designed to take a lot of heat. However, brakes can fade or fail from excessive heat caused by using them too much and not relying on the engine braking effect.

Brake fade is also affected by adjustment. To safely control a vehicle, every brake must do its share of the work. Brakes out of adjustment will stop doing their share before those that are in adjustment. The other brakes can then overheat and fade, and there will not be enough braking available to control the vehicle. Brakes can get out of adjustment quickly, especially when they are used a lot. Also, brake linings wear faster when they are hot. Therefore, brake adjustment must be checked frequently.

2.16.4 – Proper Braking Technique

Remember. The use of brakes on a long and/or steep downgrade is only a supplement to the braking effect of the engine. Once the vehicle is in the proper low gear, the following are the proper braking techniques:

1. Apply the brakes just hard enough to feel a definite slowdown.
2. When your speed has been reduced to approximately 5 mph below your “safe” speed, release the brakes. (This brake application should last for about 3 seconds.)

When your speed has increased to your “safe” speed, repeat steps 1 and 2.

For example, if your “safe” speed is 40 mph, you would not apply the brakes until your speed reaches 40 mph. You now apply the brakes hard enough to gradually reduce your speed to 35 mph and then release the brakes. Repeat this as often as necessary until you have reached the end of the downgrade.

Escape ramps have been built on many steep mountain downgrades. Escape ramps are made to stop runaway vehicles safely without injuring drivers and passengers. Escape ramps use a long bed of loose, soft material to slow a runaway vehicle, sometimes in combination with an upgrade.

Know escape ramp locations on your route. Signs show drivers where ramps are located. Escape ramps save lives, equipment, and cargo.

SUBSECTIONS 2.15 AND 2.16

Test Your Knowledge

1. What factors determine your selection of a “safe” speed when going down a long, steep downgrade?
2. Why should you be in the proper gear before starting down a hill?
3. Describe the proper braking technique when going down a long, steep downgrade.
4. What type of vehicles can get stuck on a railroad-highway crossing?
5. How long does it take a typical tractor-trailer unit to clear a double track?

These questions may be on the test. If you cannot answer them all, reread Subsections 2.15 and 2.16.

2.17 – DRIVING EMERGENCIES

Traffic emergencies occur when 2 vehicles are about to collide. Vehicle emergencies occur when tires, brakes, or other critical parts fail. Following the safety practices in this handbook can help prevent emergencies. If an emergency does happen, your chances of avoiding an accident depend upon how well you take action. Actions you can take are discussed below.

2.17.1 – Steering to Avoid an Accident

Stopping is not always the safest thing to do in an emergency. When you do not have enough room to stop, you may have to steer away from what is ahead. Remember, you can almost always turn to miss an obstacle more quickly than you can stop. (However, top-heavy vehicles and tractors with multiple trailers may flip over.)

Keep Both Hands on the Steering Wheel. In order to turn quickly, you must have a firm grip on the steering wheel with both hands. The best way to have both hands on the wheel, if there is an emergency, is to keep them there all the time.

How to Turn Quickly and Safely. A quick turn can be made safely, if it is done the right way. Here are some points that safe drivers use:

- Do not apply the brake while you are turning. It is very easy to lock your wheels while turning. If that happens, you may skid out of control.
- Do not turn any more than needed to clear whatever is in your way. The more sharply you turn, the greater the chances of a skid or rollover.
- Be prepared to countersteer (turn the wheel back in the other direction) once you have passed whatever was in your path. Unless you are prepared to countersteer, you will not be able to do it quickly enough. You should think of emergency steering and countersteering as two parts of one driving action.

Where to Steer. If an oncoming driver has drifted into your lane, a move to your right is best. If that driver realizes what has happened, the natural response will be to return to their own lane.

- If something is blocking your path, the best direction to steer will depend on the situation.
- If you have been using your mirrors, you will know which lane is empty and can be safely used.
- If the shoulder is clear, going right may be best. No one is likely to be driving on the shoulder but someone may be passing you on the left. You will know if you have been using your mirrors.
- If you are blocked on both sides, a move to the right may be best. At least you will not force anyone into an opposing traffic lane and a possible head-on accident.

Leaving the Road. In some emergencies, you may have to drive off the road. It may be less risky than facing an accident with another vehicle.

Most shoulders are strong enough to support the weight of a large vehicle, therefore; they offer an available escape route. Here are some guidelines, if you do leave the road.

- **Avoid Braking.** If possible, avoid using the brakes until your speed has dropped to about 20 mph. Then brake very gently to avoid skidding on a loose surface.
- **Keep One Set of Wheels on the Pavement, if Possible.** This helps to maintain control.
- **Stay on the Shoulder.** If the shoulder is clear, stay on it until your vehicle has come to a stop. Signal and check your mirrors before pulling back onto the road.

Returning to the Road. If you are forced to return to the road before you can stop, use the following procedure:

- Hold the wheel tightly and turn sharply enough to get right back on the road safely. Do not try to edge gradually back on the road. If you do, your tires might grab unexpectedly and you could lose control.
- When both front tires are on the paved surface, countersteer immediately. The 2 turns should be made as a single “steer-countersteer” move.

2.17.2 – How to Stop Quickly and Safely

If somebody suddenly pulls out in front of you, your natural response is to hit the brakes. This is a good response if there is enough distance to stop, and you use the brakes correctly.

You should brake in a way that will keep your vehicle in a straight line and allow you to turn if it becomes necessary. You can use the “controlled braking” or “stab braking” method.

Controlled Braking. With this method, you apply the brakes as hard as you can without locking the wheels. Keep steering wheel movements very small while doing this. If you need to make a larger steering adjustment or the wheels lock, release the brakes. Reapply the brakes as soon as you can.

Stab Braking.

- Apply your brakes all the way.
- Release the brakes when the wheels lock up.
- As soon as the wheels start rolling, apply the brakes fully again. (It can take up to 1 second for the wheels to start rolling after you release the brakes. If you reapply the brakes before the wheels start rolling, the vehicle will not straighten out.)

NOTE: Stab braking can only be done in vehicles without anti-lock brake systems (ABS).

Do Not Jam on the Brakes. Emergency braking does not mean pushing down on the brake pedal as hard as you can. That will only keep the wheels locked up and cause a skid. If the wheels skid, you cannot control the vehicle. Emergency braking means, responding to a hazard by slowing the vehicle.

NOTE: If you drive a vehicle with anti-lock brakes, you should read and follow the directions found in the owner’s manual for stopping quickly.

2.17.3 – Brake Failure

Brakes kept in good condition rarely fail. Most hydraulic brake failures occur for one of 2 reasons (air brakes are discussed in Section 5):

- Loss of hydraulic pressure.
- Brake fade on long hills.

Loss of Hydraulic Pressure. When the system will not build up pressure, the brake pedal will feel spongy or go to the floor. Here are some things you can do.

- **Downshift.** Putting the vehicle into a lower gear will help to slow the vehicle.
- **Pump the Brakes.** Sometimes pumping the brake pedal will generate enough hydraulic pressure to stop the vehicle.
- **Use the Parking Brake.** The parking or emergency brake is separate from the hydraulic brake system. Therefore, it can be used to slow the vehicle. However, be sure to press the release button or pull the release lever at the same time you use the emergency brake so you can adjust the brake pressure and keep the wheels from locking up.
- **Find an Escape Route.** While slowing the vehicle, look for an escape route, such as an open field, side street, or escape ramp. Turning uphill is a good way to slow and stop the vehicle. Make sure the vehicle does not start rolling backward after you stop. Put it in low gear, apply the parking brake, and, if necessary, roll back into an obstacle that will stop the vehicle.

Brake Failure on Downgrades. Going slow enough and braking properly will almost always prevent brake failure on long downgrades. However, once the brakes have failed, you will have to look outside your vehicle for something to stop it.

Your best hope is an escape ramp. If there is one, there will be signs telling you about it. Use it. Ramps are usually located a few miles from the top of the downgrade. Every year, hundreds of drivers avoid injury to themselves or damage to their vehicles by using escape ramps. Some escape ramps use soft gravel that resists the motion of the vehicle and brings it to a stop. Others turn uphill, using the hill to stop the vehicle and soft gravel to hold it in place.

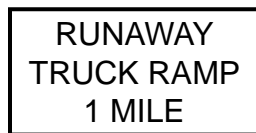

Any driver who loses brakes going downhill should use an escape ramp if it is available. If you do not use it, your chances of having a serious accident may be much greater.

If no escape ramp is available, take the least hazardous escape route you can—such as an open field or a side road that flattens out or turns uphill. Make the move as soon as you know your brakes do not work. The longer you wait, the faster the vehicle will go, and the harder it will be to stop.

2.17.4 – Tire Failure

Recognize Tire Failure. Quickly knowing you have a tire failure will allow you more time to react. Having just a few extra seconds to remember what you are supposed to do can help. The major signs of tire failure are:

- **Sound.** The loud “bang” of a blowout is an easily recognized sign. It can take a few seconds for your vehicle to react and you might think it was some other vehicle. Any time you hear a tire blow, you would be safest to assume it is yours.
- **Vibration.** If the vehicle thumps or vibrates heavily, it may be a sign one of the tires has gone flat. With a rear tire, that may be the only sign you get.
- **Feel.** If the steering feels “heavy,” it is probably a sign one of the front tires has failed. Sometimes, failure of a rear tire will cause the vehicle to slide back and forth or “fishtail.” However, dual rear tires usually prevent this.

Respond to Tire Failure. When a tire fails, your vehicle is in danger. You must immediately:

- **Hold the Steering Wheel Firmly.** If a front tire fails, it can twist the steering wheel out of your hands. The only way to prevent this is to keep a firm grip on the steering wheel with both hands at all times.
- **Stay off the Brake.** It is natural to want to brake in an emergency. However, braking when a tire has failed could cause loss of control. Unless you are about to run into something, stay off the brake until the vehicle has slowed down. Then brake very gently, pull off the road, and stop.
- **Check the Tires.** After you have come to a stop, get out and check all the tires. Do this even if the vehicle seems to be handling all right. If one of your dual tires goes, the only way you may know is by getting out and looking at it.

2.18 – ANTI-LOCK BRAKING SYSTEMS (ABS)

ABS is a computerized system that keeps your wheels from locking up during hard brake applications.

ABS is an addition to your normal brakes. It does not decrease or increase your normal braking capability. ABS only activates when wheels are about to lock up.

ABS does not necessarily shorten your stopping distance, but it helps you keep the vehicle under control during hard braking.

2.18.1 – How Anti-lock Braking Systems Work

- Sensors detect potential wheel lock up. An electronic control unit (ECU) will then decrease brake pressure to avoid wheel lockup.
- Brake pressure is adjusted to provide the maximum braking without danger of lockup.
- ABS works far faster than the driver can respond to potential wheel lockup. At all other times, the brake system will operate normally.

2.18.2 – Vehicles Required to Have ABS

The Department of Transportation (DOT) requires that ABS be on:

- Truck tractors with air brakes built on or after March 1, 1997.
- Other air brake vehicles (trucks, buses, trailers, and converter dollies) built on or after March 1, 1998.
- Hydraulically-braked trucks and buses with a GVWR of 10,000 pounds or more built on or after March 1, 1999.
- Many CMVs built before these dates have been voluntarily equipped with ABS.

2.18.3 – How to Know if Your Vehicle Is Equipped With ABS

- Tractors, trucks, and buses will have yellow ABS malfunction lamps on the instrument panel.
- Trailers will have yellow ABS malfunction lamps on the left side, either on the front or rear corner.
- Dollies manufactured on or after March 1, 1998, are required to have a yellow lamp on the left side.
- As a system check on newer vehicles, the malfunction lamp comes on at start-up for a bulb check, and then goes out quickly. On older systems, the lamp could stay on until you are driving over 5 mph.
- If the lamp stays on after the bulb check, or goes on once you are under way, you may have lost ABS control.
- In the case of towed units manufactured before it was required by DOT, it may be difficult to tell if the unit is equipped with ABS. Look under the vehicle for the ECU and wheel speed sensor wires coming from the back of the brakes.

2.18.4 – How ABS Helps You

When you brake hard on slippery surfaces in a vehicle without ABS, your wheels may lock up. When your wheels lock up, you lose steering control. When your other wheels lock up, you may skid, jackknife, or even spin the vehicle.

ABS helps you avoid wheel lock up and maintain control. You may or may not be able to stop faster with ABS, but you should be able to steer around an obstacle while braking, and avoid skids caused by over braking.

2.18.5 – ABS on the Tractor Only or Only on the Trailer

Having ABS on only the tractor, only the trailer, or even on only 1 axle, still gives you more control over the vehicle during braking. Brake normally.

When only the tractor has ABS, you should be able to maintain steering control, and there is less chance of jackknifing. However, keep your eye on the trailer and let up on the brakes (if you can safely do so) if it begins to swing out.

When only the trailer has ABS, the trailer is less likely to swing out, but if you lose steering control or start a tractor jackknife, let up on the brakes (if you can safely do so) until you regain control.

2.18.6 – Braking With ABS

When you drive a vehicle with ABS, you should brake as you always have. In other words:

- Use only the braking force necessary to stop safely and stay in control.
- Brake the same way, regardless of whether you have ABS on the bus, tractor, trailer, or both.
- As you slow down, monitor your tractor and trailer and back off the brakes (if it is safe to do so) to stay in control.

There is only one exception to this procedure. If you drive a straight truck or combination with working ABS on all axles, in an emergency stop, you can fully apply the brakes.

2.18.7 – Braking if ABS Is Not Working

Without ABS, you still have normal brake functions. Drive and brake as you always have.

Vehicles with ABS have yellow malfunction lamps to tell you if something is not working.

As a system check on newer vehicles, the malfunction lamp comes on at start-up for a bulb check and then goes out quickly. On older systems, the lamp could stay on until you are driving over 5 mph.

If the lamp stays on after the bulb check, or goes on once you are under way, you may have lost ABS control on 1 or more wheels.

Remember, if your ABS malfunctions, you still have regular brakes. Drive normally, but get the system serviced soon.

2.18.8 – Safety Reminders

- ABS will not allow you to drive faster, follow more closely, or drive less carefully.
- ABS will not prevent power or turning skids. ABS should prevent brake-induced skids or jackknives, but not those caused by spinning the drive wheels or going too fast in a turn.
- ABS will not necessarily shorten stopping distance. ABS will help maintain vehicle control, but not always shorten stopping distance.
- ABS will not increase or decrease ultimate stopping power. ABS is an “add-on” to your normal brakes, not a replacement for them.
- ABS will not change the way you normally brake. Under normal brake conditions, your vehicle will stop as it always stopped. ABS only comes into play when a wheel would normally have locked up because of over braking.
- ABS will not compensate for bad brakes or poor brake maintenance.

Remember:

- The best vehicle safety feature is still a safe driver.
- Drive so you never need to use your ABS.
- ABS could help to prevent a serious accident.

2.19 – SKID CONTROL AND RECOVERY

A skid happens whenever the tires lose their grip on the road. This is caused in one of 4 ways:

- **Over-Braking.** Braking too hard and locking up the wheels. Skids also can occur when using the speed retarder when the road is slippery.
- **Over-Steering.** Turning the wheels more sharply than the vehicle can turn.
- **Over-Acceleration.** Supplying too much power to the drive wheels, causing them to spin.
- **Driving too Fast.** Most serious skids result from driving too fast for road conditions. Drivers who adjust their driving to road conditions, and do not over-accelerate, do not have to over-brake or over-steer from too much speed.

2.19.1 – Drive-Wheel Skids

By far, the most common skid is one in which the rear wheels lose traction through excessive braking or acceleration. Skids caused by acceleration usually happen on ice or snow. Taking your foot off the accelerator can easily stop them. (If it is very slippery, push the clutch in. Otherwise, the engine can keep the wheels from rolling freely and regaining traction.)

Rear wheel braking skids occur when the rear drive wheels lock. Locked wheels have less traction than rolling wheels, and the rear wheels usually slide sideways in an attempt to “catch up” with the front wheels. In a bus or straight truck, the vehicle will slide sideways in a “spin out.” With vehicles towing trailers, a drive-wheel skid can let the trailer push the towing vehicle sideways, causing a sudden jackknife. See Figure 2.19.

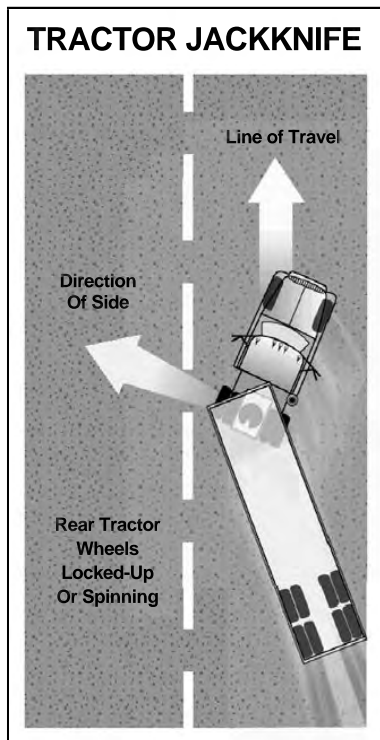

Figure 2.19

2.19.2 – Correcting a Drive-Wheel Braking Skid

Do the following to correct a drive-wheel braking skid.

- **Stop Braking.** This will let the rear wheels roll again, and keep the rear wheels from sliding.
- **Counter-steer.** As a vehicle turns back on course, it has a tendency to keep on turning. Unless you turn the steering wheel quickly the other way, you may find yourself skidding in the opposite direction.

Learning to stay off the brake, turn the steering wheel quickly, push in the clutch, and countersteer in a skid takes a lot of practice. The best place to get this practice is on a large driving range or “skid pad.”

2.19.3 – Front-Wheel Skids

Driving too fast for conditions causes most front-wheel skids. Other causes include: lack of tread on the front tires and cargo loaded so not enough weight is on the front axle. In a front-wheel skid, the front end tends to go in a straight line regardless of how much you turn the steering wheel. On a very slippery surface, you may not be able to steer around a curve or turn.

When a front-wheel skid occurs, the only way to stop the skid is to let the vehicle slow down. Stop turning and/or braking so hard. Slow down as quickly as possible without skidding.

////////////////////////////////////

SUBSECTIONS 2.17, 2.18, AND 2.19

Test Your Knowledge

1. Stopping is not always the safest thing to do in an emergency. True or False?
2. What are some advantages of going right instead of left around an obstacle?
3. What is an “escape ramp?”
4. If a tire blows out, you should put the brakes on hard to stop quickly. True or False?
5. How do you know if your vehicle has anti-lock brakes?
6. What is the proper braking technique when driving a vehicle with anti-lock brakes?
7. How do anti-lock brakes help you?

These questions may be on the test. If you cannot answer them all, reread Subsections 2.17, 2.18, and 2.19.

2.20 – ACCIDENT PROCEDURES

When you are in an accident and not seriously hurt, you need to act to prevent further damage or injury. The basic steps to be taken at any accident are to:

- Protect the area.
- Notify authorities.
- Care for the injured.
- Collect required information.
- Report the accident.

2.20.1 – Protect the Area

The first thing to do at an accident scene is to keep another accident from happening in the same spot. To protect the accident area:

- If your vehicle is involved in the accident, try to get it to the side of the road. This will help prevent another accident and allow traffic to move.
- If you are stopping to help, park away from the accident. The area immediately around the accident will be needed for emergency vehicles.
- Put on your 4-way emergency flashers.
- Set out reflective triangles to warn other traffic. Make sure other drivers can see them in time to avoid the accident.

2.20.2 – Notify Authorities

If you have a cell phone or CB radio, call for assistance before you get out of your vehicle. If not, wait until after the accident scene has been properly protected, then phone or send someone to phone the police. Try to determine where you are so you can give the exact location.

2.20.3 – Care for the Injured

If a qualified person is at the accident and helping the injured, stay out of the way unless asked to assist. Otherwise, do the best you can to help any injured parties. Here are some simple steps to follow in giving assistance:

- Do not move a severely injured person unless the danger of fire or passing traffic makes it necessary.
- Stop heavy bleeding by applying direct pressure to the wound.
- Keep the injured person warm.

2.20.4 – Gather Information

If you were involved in the accident, you will have to file an accident report. Collect the following information for the report:

- Names, addresses, and DL numbers of drivers involved in the accident.
- License plate numbers and types of vehicles involved in the accident.
- Names and addresses of the owners of other vehicles (if different from the drivers).
- Description of the damages to other vehicles or to property.
- Name(s) and address(es) of anyone who was injured or involved in the accident.
- Name, badge number, and agency of any peace officer investigating the accident.
- Names and addresses of witnesses.
- Exact location of the accident.
- Direction of travel of the vehicles involved..

2.21 – FIRES

Truck fires can cause damage and injury. Learn the causes of fires and how to prevent them. Know what to do to extinguish fires.

2.21.1 – Causes of Fire

The following are some causes of vehicle fires:

- **After Accidents.** Spilled fuel and improper use of flares.
- **Tires.** Under-inflated tires and dual tires that touch.
- **Electrical System.** Short circuits due to damaged insulation and loose connections.
- **Fuel.** Driver smoking, improper fueling, and loose fuel connections.
- **Cargo.** Flammable cargo, improperly sealed or loaded cargo, and poor ventilation.

2.21.2 – Fire Prevention

Pay attention to the following:

- **Vehicle Inspection.** Make a complete inspection of the electrical, fuel, and exhaust systems, tires, and cargo. Be sure to check that the fire extinguisher is charged.
- **En Route Inspection.** Check the tires, wheels, and truck body for signs of heat whenever you stop during a trip.

- **Follow Safe Procedures.** Follow correct safety procedures for fueling the vehicle, using brakes, handling flares, and other activities that can cause a fire.
- **Monitoring.** Check the instruments and gauges often for signs of overheating and use the mirrors to look for signs of smoke from tires or the vehicle.
- **Caution.** Use caution handling anything flammable.

2.21.3 – Fire Fighting

Knowing how to fight fires is important. Drivers who did not know what to do have made fires worse. Know how the fire extinguisher works. Study the instructions printed on the extinguisher before you need it. Here are some procedures to follow in case of fire.

Pull Off the Road. The first step is to get the vehicle off the road and stop. In doing so:

- Park in an open area, away from buildings, trees, brush, other vehicles, or anything that might catch fire.
- Do not pull into a service station!
- Notify emergency services of your problem and location.

Keep the Fire From Spreading. Before trying to put out the fire, make sure that it does not spread any further.

- **With an engine fire,** turn off the engine as soon as you can. Do not open the hood if you can avoid it. Shoot foam through louvers, radiator, or from the vehicle’s underside.

- **For a cargo fire in a van or box trailer,** keep the doors shut, especially if your cargo contains HazMat. Opening the van doors will supply the fire with oxygen and can cause it to burn very fast.

Extinguish the Fire. Here are some rules to follow in putting out a fire:

- When using the extinguisher, stay as far away from the fire as possible.
- Aim at the source or base of the fire, not up in the flames.

NOTE: Refer to CCR, Title 13 §1242 for additional information.

Use the Correct Fire Extinguisher. Figures 2.20 and 2.21 detail the type of fire extinguisher to use by class of fire.

- The B:C type fire extinguisher is designed to work on electrical fires and burning liquids.
- The A:B:C type is designed to work on burning wood, paper, and cloth as well.
- Water can be used on wood, paper, or cloth, but do not use water on an electrical fire (can cause shock) or a gasoline fire (will spread the flames).
- A burning tire must be cooled. Lots of water may be required.
- If you are not sure what to use, especially on a HazMat fire, wait for firefighters.
- Position yourself upwind. Let the wind carry the extinguisher to the fire.
- Continue until whatever was burning has cooled. Absence of smoke or flame does not mean the fire cannot restart.

CLASS/TYPE OF FIRES	
Class	Type
Z	Wood, Paper, Ordinary Combustibles Extinguish by Cooling and Quenching Using Water or Dry Chemicals
B	Gasoline, Oil, Grease, Other Greasy Liquids Extinguish by Smothering, Cooling or Heat Shielding using Carbon Dioxide or Dry Chemicals
C	Electrical Equipment Fires Extinguish with Nonconducting Agents such as Carbon Dioxide or Dry Chemicals. Do Not Use Water.
D	Fires In Combustible Metals Extinguish by Using Specialized Extinguishing Powders

Figure 2.20

CLASS OF FIRE/TYPE OF EXTINGUISHER	
Class of Fire	Fire Extinguisher Type
B or C	Regular Dry Chemical
A, B, C, or D	Multi-Purpose Dry Chemical
D	Purple K Dry Chemical
B or C	KCL Dry Chemical
D	Dry Powder Special Compound
B or C	Carbon Dioxide (Dry)
B or C	Halogenated Agent (Gas)
A	Water
A	Water With Anti-Freeze
A or B	Water, Loaded Stream Style
B, On Some A	Foam

Figure 2.21

SUBSECTIONS 2.20 AND 2.21

Test Your Knowledge

1. What are some things to do at an accident scene to prevent another accident?
2. Name 2 causes of tire fires.
3. What kinds of fires is a B:C extinguisher not good for?
4. When using your extinguisher, should you get as close as possible to the fire?
5. Name some causes of vehicle fires.

These questions may be on the test. If you cannot answer them all, reread Subsections 2.20 and 2.21.

WHAT IS A DRINK?									
It is the alcohol in drinks that affects human performance. It does not make any difference whether that alcohol comes from "a couple of beers," or from 2 glasses of wine, or 2 shots of hard liquor.									
Approximate Blood Alcohol Content									
Drinks	Body Weight in Pounds								Effects
	100	120	140	160	180	200	220	240	
0	.00	.00	.00	.00	.00	.00	.00	.00	Only Safe Driving Limit
1	.04	.03	.03	.02	.02	.02	.02	.02	Impairment Begins
2	.08	.06	.05	.05	.04	.04	.03	.03	Driving Skills Significantly Affected Criminal Penalties
3	.11	.09	.08	.07	.06	.06	.05	.05	
4	.15	.12	.11	.09	.08	.08	.07	.06	
5	.19	.16	.13	.12	.11	.09	.09	.08	
6	.23	.19	.16	.14	.13	.11	.10	.09	Legally Intoxicated Criminal Penalties
7	.26	.22	.19	.16	.15	.13	.12	.11	
8	.30	.25	.21	.19	.17	.15	.14	.13	
9	.34	.28	.24	.21	.19	.17	.15	.14	
10	.38	.31	.27	.23	.21	.19	.17	.16	

Subtract .01% for each 40 minutes of drinking. 1 drink is 1.5 oz. of 80 proof liquor, 12 oz. of beer, or 5 oz. of table wine.

Figure 2.22

2.22 – ALCOHOL, OTHER DRUGS, AND DRIVING

2.22.1 – Alcohol and Driving

Drinking alcohol and then driving is very dangerous and a serious problem. People who drink alcohol are involved in traffic accidents resulting in over 20,000 deaths every year. Alcohol impairs muscle coordination, reaction time, depth perception, and night vision. It also affects the parts of the brain that control judgment and inhibition. For some people, 1 drink is all it takes to show signs of impairment.

You should know:

- How alcohol works in the human body.
- How alcohol affects driving.
- Laws regarding drinking, drugs, and driving.
- Legal, financial, and safety risks of drinking and driving.

You may **NEVER** drink while on duty or consume any intoxicating beverage, regardless of its alcohol content, within 4 hours before going on duty.

EFFECTS OF INCREASING BLOOD ALCOHOL CONTENT		
Blood Alcohol Content is the amount of alcohol in your blood recorded in milligrams of alcohol per 100 milliliters of blood. Your BAC depends on the amount of blood (which increases with weight) and the amount of alcohol you consume over time (how fast you drink). The faster you drink, the higher your BAC, as the liver can only handle about 1 drink per hour—the rest builds up in your blood.		
BAC	Effects on Body	Effects on Driving Condition
.02	Mellow feeling, slight body warmth.	Less inhibited.
.05	Noticeable relaxation.	Less alert, less self-focused, coordination impairment begins.
.08	Definite impairment in coordination & judgment.	Drunk driving limit, impaired coordination & judgment.
.10*	Noisy, possible embarrassing behavior, mood swings.	Reduction in reaction time.
.15	Impaired balance & movement, clearly drunk.	Unable to drive.
.30	Many lose consciousness.	
.40	Most lose consciousness, some die.	
.50	Breathing stops, many die.	

*BAC of .10 means that 1/10 of 1% (or 1/1000) of your total blood content is alcohol.

Figure 2.23

Remember—it is illegal to drive a commercial motor vehicle with a blood alcohol concentration (BAC) that is 0.04 percent or greater. Doing so will result in an immediate administrative driver licensing sanction (Admin Per Se) in accordance with CVC §13353.2(3). You may also be convicted of driving under the influence of alcohol or drugs (CVC §23152(d)). However, a BAC below 0.04 percent does not mean that it is safe or legal to drive.

How Alcohol Works. Alcohol goes directly into the blood stream and is carried to the brain. After passing through the brain, a small percentage is removed in urine, perspiration, and breathing, while the rest is carried to the liver. The liver can only process 1/3 an ounce of alcohol per hour, which is considerably less than the alcohol in a standard drink. This is a fixed rate, so only time, not black coffee or a cold shower, will sober you up. If you have drinks faster than your body can get rid of them, you will have more alcohol in your body, and your driving will be more affected. The BAC commonly measures the amount of alcohol in your body. See Figure 2.22.

All of the following drinks contain the same amount of alcohol:

- A 12-ounce glass of 5 percent beer.
- A 5-ounce glass of 12 percent wine.
- A 1-1/2 ounce shot of 80 proof liquor .

What Determines Blood Alcohol Concentration?

BAC is determined by the amount of alcohol you drink (more alcohol means higher BAC), how fast you drink (faster drinking means higher BAC), and your weight (a small person does not have to drink as much to reach the same BAC).

Alcohol and the Brain. Alcohol affects more and more of the brain as BAC builds up. The first part of the brain affected controls judgment and self-control. One of the bad things about this is it can keep drinkers from knowing they are getting drunk. Of course, good judgment and self-control are absolutely necessary for safe driving.

As BAC continues to build up, muscle control, vision, and coordination are affected more and more. Effects on driving may include:

- Straddling lanes.
- Quick, jerky starts.
- Not signaling and failure to use lights.
- Running stop signs and red lights.
- Improper passing (See Figure 2.23).

These effects mean increased chances of an accident and losing your DL. Accident statistics show that the chance of an accident is much greater for drivers who have been drinking than for drivers who have not.

How Alcohol Affects Driving. All drivers are affected by drinking alcohol. Alcohol affects judgment, vision, coordination, and reaction time. It causes serious driving errors, such as:

- Increased reaction time to hazards.
- Driving too fast or slow.
- Driving in the wrong lane.
- Running over the curb.
- Weaving.

2.22.2 – Other Drugs

Besides alcohol, other legal and illegal drugs are being used more often. Laws prohibit possession or use of many drugs while on duty. They prohibit being under the influence of any “controlled substance,” amphetamines (including “pep pills,” “uppers,” and “bennies”), narcotics, or any other substance, which can make the driver unsafe. This could include a variety of prescription and over-the-counter drugs (cold medicines), which may make the driver drowsy or otherwise affect safe driving ability. However, possession and use of a drug given to a driver by a doctor is permitted if the doctor informs the driver that it will not affect safe driving ability.

Pay attention to warning labels for legitimate drugs and medicines, and to doctor’s orders regarding possible effects. Stay away from illegal drugs.

Do not use any drug that hides fatigue. The only cure for fatigue is rest. Alcohol can make the effects of other drugs much worse. The safest rule is do not mix drugs with driving at all.

Use of drugs can lead to traffic accidents resulting in death, injury, and property damage. Furthermore, it can lead to arrest, fines, and jail sentences. It can also mean the end of a person’s driving career.

2.22.3 – Illness

Occasionally, you may become so ill that you cannot operate a motor vehicle safely. If this happens to you, you must not drive. However, in case of an emergency, you may drive to the nearest place where you can safely stop.

2.23 – HAZARDOUS MATERIALS RULES FOR ALL COMMERCIAL DRIVERS

All drivers should know something about HazMat. You must be able to recognize hazardous cargo, and know whether or not you can haul it without having an “H” endorsement on your CDL.

If you apply for an original or renewal “H” endorsement, you must undergo a Transportation Security Administration (TSA) federal security threat assessment (background records check). You start the TSA background records check after you apply for your CDL at DMV, successfully complete all appropriate knowledge tests, and submit a valid medical form. You must submit fingerprints, a fee, and any additional required information to one of TSA’s designated agents. You must also provide the TSA agent with a copy of your CLP and one of the following ID documents:

- A California DL/ID card.
- An out-of-state DL.
- Your CLP accompanied by a DMV photo receipt.

For a list of TSA agent sites, visit universalenroll.dhs.gov or call 1-855-347-8371.

2.23.1 – What Are Hazardous Materials?

HazMat are products that pose a risk to health, safety, and property during transportation. See Figure 2.24.

2.23.2 – Why Are There Rules?

You must follow the many rules about transporting HazMat. The intent of the rules is to:

- **Contain the product.**
- **Communicate the risk.**
- **Ensure safe drivers and equipment.**

Contain the Product. Many hazardous products can injure or kill on contact. To protect drivers and others from contact, the rules tell shippers how to package products safely. Similar rules tell drivers how to load, transport, and unload bulk tanks. These are containment rules.

Communicate the Risk. The shipper uses a shipping paper and diamond-shaped hazard labels to warn dockworkers and drivers of the risk.

After an accident or HazMat spill or leak, you may be injured and unable to communicate the hazards of the materials you are transporting. Firefighters and police can prevent or reduce the amount of damage or injury at the scene if they know what HazMat is

being transported. Your life, and the lives of others, may depend on quickly locating the HazMat shipping papers. For that reason, you must identify shipping papers related to HazMat or keep them on top of other shipping papers. You must also keep shipping papers in or on:

- A pouch on the driver’s door.
- Clear view within reach while driving.
- The driver’s seat when out of the vehicle.

2.23.3 – Lists of Regulated Products

Placards are used to warn others of HazMat. Placards are signs put on the outside of a vehicle that identify the hazard class of the cargo. A placarded vehicle must have at least 4 identical placards. They are put on the front, rear, and both sides. Placards must be readable from all 4 directions. They must be at least 9.84 (250 mm) inches square, turned upright on a point, and in a diamond shape. Cargo tanks and other bulk packaging display the ID number of their contents on placards or orange panels (CVC §27903).

ID Numbers are a 4-digit code used by first responders to identify HazMat. An ID number may be used to identify more than one chemical on shipping papers. The ID number will be preceded by the letters “NA” or “UN.” The U.S. DOT *Emergency Response Guidebook* (ERG) lists the chemicals and ID numbers assigned to them.

HAZARD CLASS DEFINITIONS		
Class	Class Name	Example
1	Explosives	Ammunition, Dynamite, Fireworks
2	Gases	Propane, Oxygen, Helium
3	Flammable	Gasoline, Acetone
4	Flammable Solids	Matches, Fuses
5	Oxidizers	Ammonium Nitrate, Hydrogen Peroxide
6	Poisons	Pesticides, Arsenic
7	Radioactive	Uranium, Plutonium
8	Corrosives	Hydrochloric Acid, Battery Fluid
9	Miscellaneous Hazardous Materials	Formaldehyde, Asbestos
None	ORM-D (Other Regulated Material-Domestic)	Hair Spray or Charcoal
None	Combustible Liquids	Fuel Oils, Lighter Fluid

Figure 2.24

Not all vehicles carrying HazMat need to have placards. The rules about placards are given in Section 9 of this handbook. You can drive a vehicle that carries HazMat if it does not require placards. If it requires placards, you cannot drive it unless your DL has an “H” endorsement. See Figure 2.25.

The rules require all drivers of placarded vehicles to learn how to safely load and transport hazardous products and to have a CDL with the “H” endorsement. To get the required endorsement, you must pass a knowledge test on material found in Section 9 of this handbook. An “X” endorsement is required for CMVs that transport liquid or gaseous materials within a tank or tanks having an individual rated capacity of more than 119 gallons and an aggregate rated capacity of 1,000 gallons or more that is either permanently or temporarily attached to the vehicle or chassis. A CMV transporting an empty storage container tank, not designed for transportation, with

a rated capacity of 1,000 gallons or more that is temporarily attached to a flatbed trailer is not considered a tank vehicle (CFR, Title 49 §383.5).

NOTE: An “N” endorsement is not necessary for the operation of vehicles that do not require a CDL.

Drivers who need the “H” endorsement must learn the placard rules. If you do not know if your vehicle needs placards, ask your employer. Never drive a vehicle needing placards unless you have the “H” endorsement. To do so is a crime. When stopped, you will be cited and you will not be allowed to drive your truck. It will cost you time and money. A failure to placard when needed may risk your life and the lives of others if you have an accident. Emergency help will not know of your hazardous cargo.

Drivers who need an “H” endorsement must also know which products they can load together, and which they cannot. These rules are also in Section 9. Before loading a truck with more than one type of product, you must know if it is safe to load them together. If you do not know, ask your employer and consult the regulations.

SUBSECTIONS 2.22 AND 2.23

Test Your Knowledge

1. Common medicines for colds can make you sleepy. True or False?
2. Coffee and a little fresh air will help a drinker sober up. True or False?
3. What is a HazMat placard?
4. Why are placards used?

These questions may be on the test. If you cannot answer them all, reread Subsections 2.22 and 2.23.

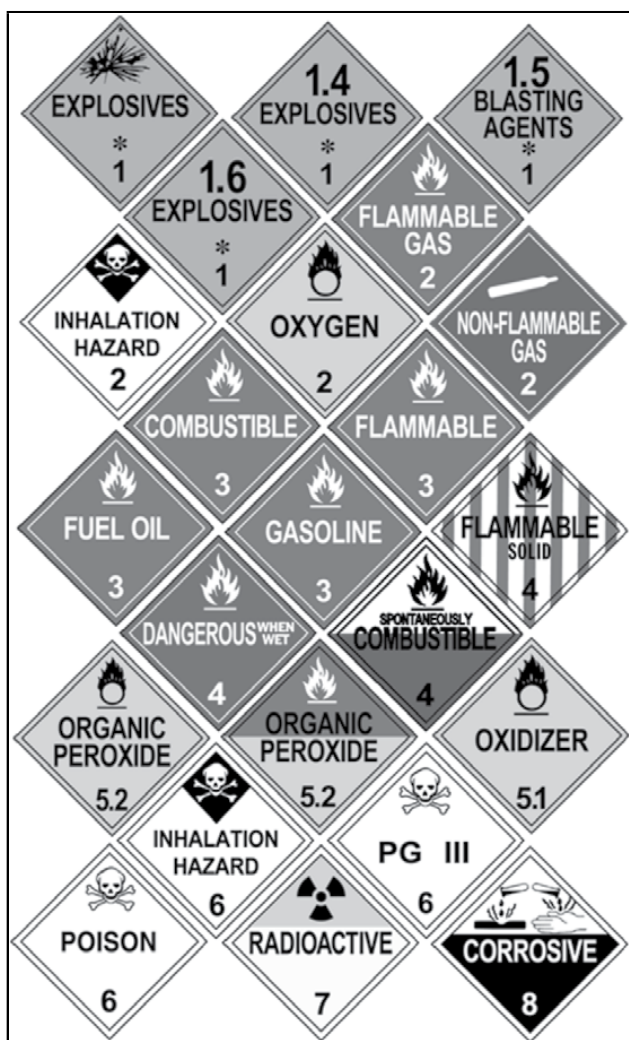
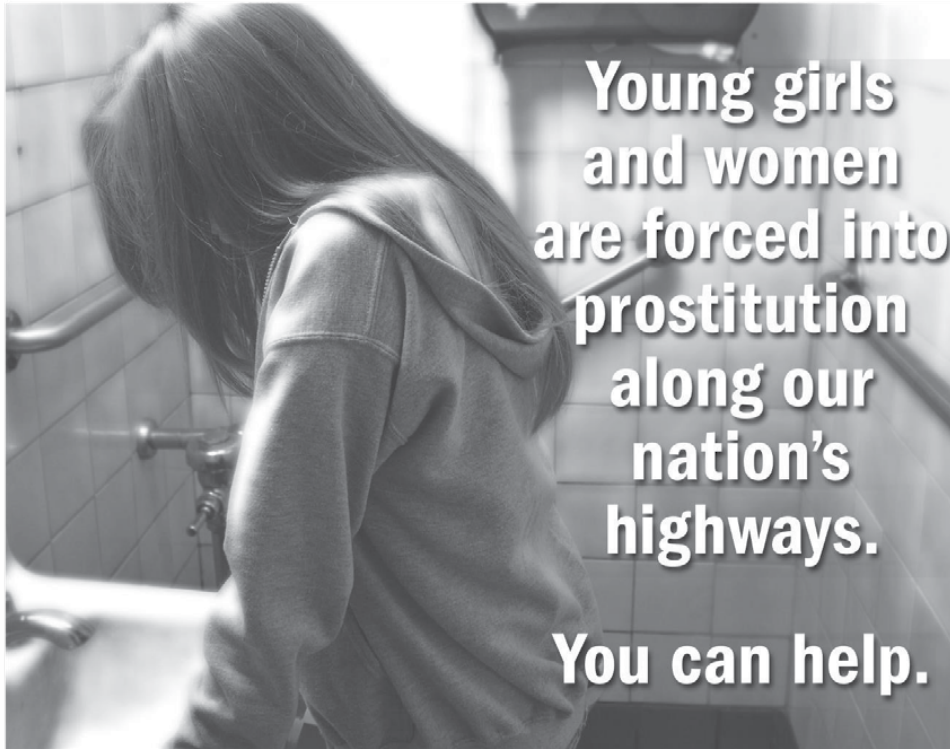

Figure 2.25



Everyday Heroes Needed.



Make the Call, Save Lives.

**National Hotline:
1-888-373-7888**

truckersagainsttrafficking.org



Human trafficking is modern-day slavery. Traffickers use force, fraud and coercion to control their victims. Any minor engaged in commercial sex is a victim of human trafficking. Trafficking can occur in many locations, including truck stops, restaurants, rest areas, brothels, strip clubs, private homes, etc.

Truckers are the eyes and the ears of our nation's highways and are already making calls that are saving lives. If you see a minor working any of those areas or suspect pimp control, call the national hotline and report your tip.

**1-888-373-7888 (US)
1-800-222-TIPS (Canada)
01800-5533-000 (Mexico)**

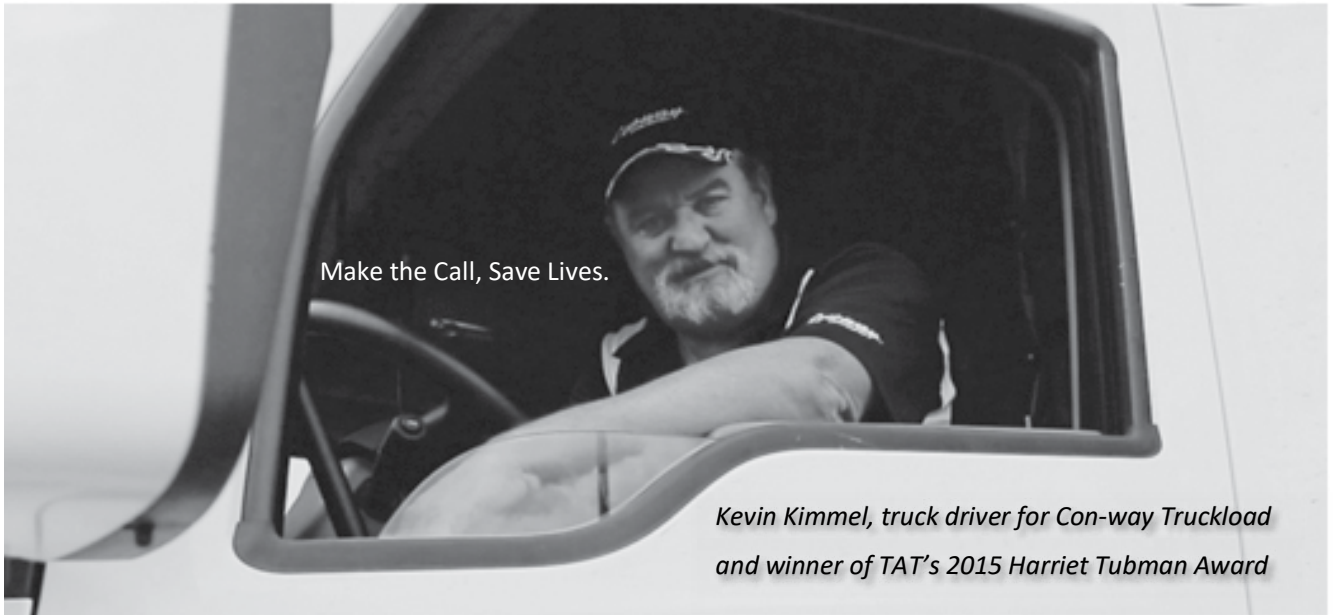

Make the Call, Save Lives.

Kevin Kimmel, truck driver for Con-way Truckload and winner of TAT's 2015 Harriet Tubman Award

In January 2015, an RV pulled into a truck stop in Virginia. Observant professional truck driver Kevin Kimmel recognized suspicious activity around that RV, which had pulled back by the truck line, and decided something was off. Instead of turning a blind eye, he made a call that brought law enforcement out to the scene within a few minutes. After interviewing the occupants of the vehicle, they discovered that a young woman, 20 years old, had been kidnapped from Iowa two weeks prior. She had been beaten, raped, her whole body burned by instruments heated on the RV stove, branded and starved. She was being sold by her traffickers, Laura Sorenson and Aldair Hodza, through sex ads on Craigslist, where men were purchasing her and then arriving at the RV to rape her. She was dying from malnutrition and the torture she was subjected to ... had the call not been made that brought law enforcement out to that truck stop, doctors said she would have died within the next few days. Now a recovering survivor, this young woman calls Kimmel her guardian angel. He calls himself a Trucker Against Trafficking.

Truckers Against Trafficking is a non-profit organization that has been working with the trucking industry since 2009 to provide the needed training and tools to enable members of the industry to both recognize human trafficking when they see it happening and to know what actions to take to enable law enforcement to effectively fight this crime. Through this training and these tools, truckers are becoming Everyday Heroes like Kevin Kimmel, who was also named TAT's 2015 Harriet Tubman Award winner.

One of the tools TAT provides is a wallet card with red flags to look for, questions to ask if you suspect someone is a victim and actionable information to report. This wallet card is available by App, from the appropriate App Store, on all smart phones, whether Android, iPhone or Windows format, as well as by emailing tat.truckers@gmail.com, for a version to carry in your wallet.

Additionally, TAT provides a powerful, 26-minute training video on its website (www.truckersagainsttrafficking.org), which, when watched along with taking and passing a short test, certifies drivers as TAT-Trained, a designation which can go on your resume. Because professional drivers often find themselves in locations frequented and exploited by human traffickers, they are in a unique position to recognize the signs of human trafficking and to make the call that can lead to victim recovery and perpetrator arrests. Get your wallet card today. Be an Everyday Hero! Make the call (1-888-3737-888); save lives!

Human trafficking is modern day slavery. Traffickers use force, fraud and coercion to control their victims. Any minor engaged in commercial sex is a victim of human trafficking. Trafficking can occur in many locations, including truck stops, restaurants, rest areas, hotels/motels, strip clubs, private homes, etc. Truckers are the eyes and the ears of our nation's highways. If you see a minor working any of those areas or suspect that the person selling sex is under someone else's control in order to make a quota, call the National Hotline and report your tip:

1-888-3737-888 (US) • 1-800-222-TIPS (Canada)
01800-5533-000 (Mexico) • Text INFO or HELP to BeFree (233733)

For law enforcement to open an investigation on your tip, they need "actionable information," and as many details as you can provide. Specific tips helpful when reporting to the hotline would include:

- Descriptions of cars (make, model, color, license plate number, etc.) and people (height, weight, hair color, eye color, age, etc.)
- Take a picture if you can.
- Specific times and dates (When did you see the event in question take place? What day was it?)
- Addresses and locations where suspicious activity took place

Make the Call, Save Lives.

Questions to Ask:
 Do you keep your own money? If not, who does?
 Do your parents/siblings/relatives know where you are? If not, why not?
 When was the last time you saw your family?
 Are you physically or sexually abused? Are you or your family threatened? What is the nature of the threats?

Trafficking Red Flags to Look For:

- Lack of knowledge of their community or whereabouts
- Restricted or controlled communication-not allowed to speak for self
- CB chatter about "commercial company" or flashing lights signaling "buyer" location
- Not in control of own identification documents (ID/passport)
- Any acknowledgement that she/he has a pimp and is making a quota
- Signs of branding or tattooing of trafficker's name (often on the neck)



1-888-3737-888 (US)
1-800-222-TIPS (Canada)
01800-5533-000 (Mexico)
Text INFO or HELP to BeFree (233733)

SHARE the Road



Courtesy Counts



SECTION 3: TRANSPORTING CARGO SAFELY

THIS SECTION COVERS

- 3.1 – Inspecting Cargo
 - 3.2 – Cargo Weight and Balance
 - 3.3 – Securing Cargo
 - 3.4 – Cargo Needing Special Attention
-

This section tells you about hauling cargo safely. You must understand basic cargo safety rules to get a CDL.

If you load cargo wrong or do not secure it properly, it can be a danger to others and yourself. Loose cargo that falls off a vehicle can cause traffic problems and others could be hurt or killed. Loose cargo could hurt or kill you during a quick stop or accident. Your vehicle could be damaged by an overload. Steering could be affected by how a vehicle is loaded, making it more difficult to control the vehicle.

Whether or not you load and secure the cargo yourself, you are responsible for:

- Inspecting your cargo.
- Recognizing overloads and poorly balanced weight.
- Knowing your cargo is properly secured and does not obscure your view ahead or to the sides.
- Knowing your cargo does not restrict your access to emergency equipment.

If you intend to carry HazMat that requires placards on your vehicle, you will also need to have an “H” endorsement. Section 9 of this handbook has the information you need to pass the HazMat test.

3.1 – INSPECTING CARGO

As part of your vehicle inspection, make sure the truck is not overloaded and the cargo is balanced and secured properly.

After Starting. Inspect the cargo and its securing devices again within the first 50 miles after beginning a trip. Make any adjustments needed.

Re-Check. Re-check the cargo and securing devices as often as necessary during a trip to keep the load secure. You need to inspect again:

- After you have driven for 3 hours or 150 miles.
- After every break you take during your trip.

Federal, state, and local regulations for CMV weight, securing cargo, covering loads, and where you can drive large vehicles vary from place to place. Know the rules where you will be driving.

3.2 – CARGO WEIGHT AND BALANCE

You are responsible for not being overloaded. The following are some definitions of weight you should know.

3.2.1 – Definitions you Should Know

Gross Vehicle Weight (GVW). The total weight of a single vehicle including its load.

Gross Combination Weight (GCW). The total weight of a combination of vehicles including the load.

Gross Vehicle Weight Rating (GVWR). The value specified by the manufacturer as the loaded weight of a single vehicle.

Gross Combination Weight Rating (GCWR). The value specified by the manufacturer as the loaded weight of a combination (articulated) vehicle. *In the absence of a value specified by the manufacturer, GCWR will be determined by adding the GVWR of the power unit, the total weight of the towed unit, and any load thereon.*

Axle Weight. The weight transmitted to the ground by 1 axle or one set of axles.

Tire Load. The maximum safe weight a tire can carry at a specified pressure. This rating is stated on the side of each tire.

Suspension Systems. Suspension systems have a manufacturer's weight capacity rating.

Coupling Device Capacity. Coupling devices are rated for the maximum weight they can pull and/or carry.

3.2.2 – Legal Weight Limits

You must keep weights within legal limits. States have maximums for GVWRs, GCWRs, and axle weights. Often, maximum axle weights are set by a bridge formula. A bridge formula permits less maximum axle weight for axles that are closer together. This is to prevent overloading bridges and roadways.

Overloading can have bad effects on steering, braking, and speed control. Overloaded trucks have to go very slowly on upgrades. Worse, they may gain too much speed on downgrades. Stopping distance increases. Brakes can fail when forced to work too hard.

During bad weather or in mountains, it may not be safe to operate at legal maximum weights. Take this into account before driving.

3.2.3 – Do Not Be Top-Heavy

The height of the vehicle's center of gravity is very important for safe handling. A high center of gravity (cargo piled up high or heavy cargo on top) means you are more likely to tip over. It is most dangerous in curves, or if you have to swerve to avoid a hazard. It is very important to distribute the cargo as low as possible. Put the heaviest parts of the cargo under the lightest parts.

3.2.4 – Balance the Weight

Poor weight balance can make vehicle handling unsafe. Too much weight on the steering axle can cause hard steering. It can damage the steering axle and tires. Under-loaded front axles (caused by shifting weight too far to the rear) can make the steering axle weight too light to steer safely. Too little weight on the driving axles can cause poor traction. The drive wheels may spin easily. During bad weather, the truck may not be able to keep going. Weight loaded with a high center of gravity causes a greater chance of rollover. On flatbed vehicles, there is also a greater chance that the load will shift to the side or fall off. See Figure 3.1.

3.3 – SECURING CARGO

3.3.1 – Blocking and Bracing

Blocking is used in the front, back, and/or sides of a piece of cargo to keep it from sliding. Blocking is shaped to fit snugly against cargo. It is secured to the cargo deck to prevent cargo movement. Bracing is also used to prevent movement of cargo. Bracing goes from the upper part of the cargo to the floor and/or walls of the cargo compartment.

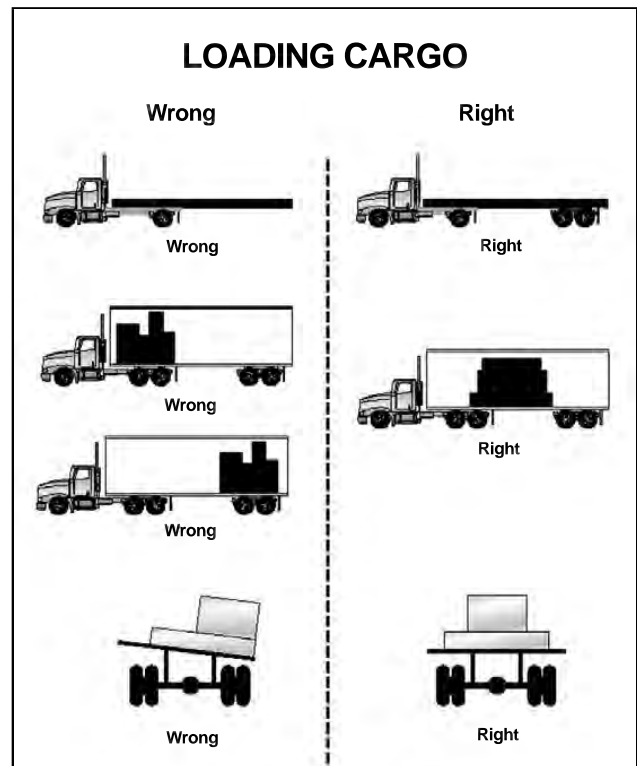

Figure 3.1

3.3.2 – Cargo Tie-down

On flatbed trailers or trailers without sides, cargo must be secured to keep it from shifting or falling off. In closed vans, tie-downs can also be important to prevent cargo shifting that may affect the handling of the vehicle. Tie-downs must be of the proper type and strength. Federal regulations require the aggregate working load limit of any securement system used to secure an article or group of articles against movement must be at least 1/2 times the weight of the article or group of articles. Proper tie-down equipment must be used, including ropes, straps, chains, and tensioning devices (such as, winches, ratchets, and clinching components). Tie-downs must be attached to the vehicle correctly (with hooks, bolts, rails, rings). See Figure 3.2.

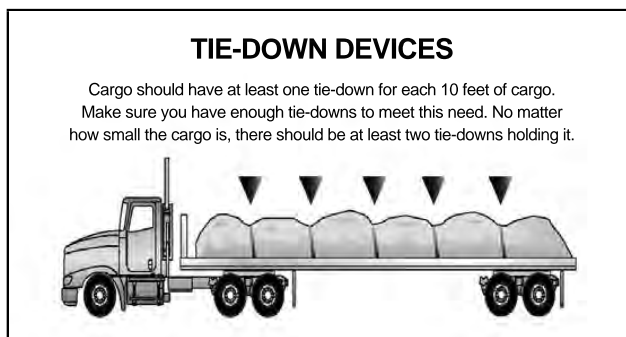

Figure 3.2

Cargo should have at least one tie-down for each 10 feet of cargo. Make sure you have enough tie-downs to meet this need. No matter how small the cargo, it should have at least 2 tie-downs.

There are special requirements for securing various heavy pieces of metal. Find out what they are if you are to carry such loads.

Rules governing the loading and securement of logs, dressed lumber, metal coils, paper rolls, concrete pipe, intermodal containers, automobiles, heavy vehicles, flattened or crushed vehicles, roll-on/roll-off containers, and large boulders are contained in the CFR, Title 49 §393.

3.3.3 – Header Boards

Front-end header boards (“headache racks”) protect you from your cargo in case of an accident or emergency stop. Make sure the front-end structure is in good condition. The front-end structure should block the forward movement of any cargo you carry.

3.3.4 – Covering Cargo

There are 2 basic reasons for covering cargo:

- To protect people from spilled cargo.
- To protect the cargo from weather.

Spill protection is a safety requirement in many states. Be familiar with the laws in the states you drive in.

You should look at your cargo covers in the mirrors from time to time while driving. A flapping cover can tear loose, uncovering the cargo, and possibly blocking your view or someone else’s.

3.3.5 – Sealed and Containerized Loads

Containerized loads generally are used when freight is carried part way by rail or ship. Delivery by truck occurs at the beginning and/or end of the journey. Some containers have their own tie-down devices or locks that attach directly to a special frame. Others have to be loaded onto flatbed trailers. They must be properly secured just like any other cargo.

You cannot inspect sealed loads, but you should check that you do not exceed gross weight and axle weight limits.

3.3.6 – Spilling Loads and Damage to the Highway

It is against the law to operate on the highway a vehicle which is improperly covered, constructed, or loaded so that any part of its contents or load spills, drops, leaks, blows, sifts, or in any other way escapes from the vehicle. **EXCEPTION:** clear water or feathers from live birds (CVC §§23114 and 23115).

Any vehicle transporting garbage, trash, rubbish, ashes, etc., must have the load covered to prevent any part of the load from spilling on to the highway. Aggregate material must be carried in the cargo area of the vehicle and be 6 inches below the upper edge. The cargo area must not have any holes, cracks, or openings which could allow the material to escape. The vehicle used to transport aggregate material must be equipped with seals on any openings used to empty the load, splash flaps behind every tire or set of tires, and fenders. Other requirements are listed in CVC §23114. This does not apply to vehicles carrying wet, waste fruit, or vegetable matter, or waste from food processing plants.

Any person who willfully or negligently damages any street or highway is liable for the cost of repairing the road or any sign, signal, guard rail, or other facility that is damaged. The liability may include the cost of removing debris from the roadway.

3.4 – CARGO NEEDING SPECIAL ATTENTION

3.4.1 – Dry Bulk

Dry bulk tanks require special care because they have a high center of gravity, and the load can shift. Be extremely cautious (slow and careful) going around curves and making sharp turns.

3.4.2 – Hanging Meat

Hanging meat (suspended beef, pork, lamb) in a refrigerated truck can be a very unstable load with a high center of gravity. Particular caution is needed on sharp curves such as off ramps and on ramps. Go slowly.

3.4.3 – Livestock

Livestock can move around in a trailer, causing unsafe handling. With less than a full load, use false bulkheads to keep livestock bunched together. Even when bunched, special care is necessary because livestock can lean on curves. This shifts the center of gravity and makes rollover more likely.

3.4.4 – Oversized Loads

Over-length, over-width, and/or overweight loads require special (Caltrans in California) transit permits. Driving is usually limited to certain times. Special equipment may be necessary such as “wide load” signs, flashing lights, flags, etc. Such loads may require a police escort or pilot vehicles bearing warning signs and/or flashing lights. These special loads require special driving care.

3.4.5 – Special Markings Needed

Any vehicle and load over 80 inches in width must, in addition to required vehicle lighting, show an amber combination clearance and side-marker lamp on the side of the load projection at the front and show a red combination clearance and side-marker lamp on the side of the projection at the rear.

Alternatively, if the over width of the projection does not extend more than 3 feet from front to rear, and the projection is near the front of the vehicle, at least one amber combination clearance lamp must be visible from the front, side, and rear at the extreme width. If the projection is near the rear, at least one red combination side clearance lamp must be displayed (CVC §25100).

3.4.6 – Projecting Loads

Lights (or Flags) on Projecting Loads. When the load on any vehicle extends 4 feet (48 inches) or more beyond the rear of the body, a solid red or fluorescent orange flag at least 12 inches square must be placed at the extreme end of the load. If the vehicle is operated during darkness, there must be 2 lit red lights at the end of the load, visible at a distance of 500 feet to the side and rear of the vehicle (CVC §24604).

A load extending 1 foot or more to the left on any vehicle must have an amber light on the extreme left side of the load. It must be visible at least 300 feet to the front and rear during darkness. If the load extends more than 120 inches, there must be an amber lamp at the front and a red lamp at the rear, each visible at least 300 feet.

If the vehicle is wider than 102 inches, a red or fluorescent flag not less than 12 inches square must be displayed at the left front and left rear during daylight (CVC §25104).

3.4.7 – Piggyback Trailers

When any trailer is loaded upon another vehicle (piggyback) to be moved on any highway, the trailer must be securely bound to the vehicle to prevent the trailer from shifting, toppling over, or becoming unstable.

SECTION 3

Test Your Knowledge

1. What 4 things related to cargo are drivers responsible for?
2. How often must you stop while on the road to check your cargo?
3. How is gross combination weight rating different from gross combination weight?
4. Name 2 situations where legal maximum weights may not be safe.
5. What can happen if you do not have enough weight on the front axle?
6. What is the minimum number of tie-downs for any flatbed load?
7. What is the minimum number of tie-downs for a 20-foot load?
8. Name the 2 basic reasons for covering cargo on an open bed.
9. What must you check before transporting a sealed load?

These questions may be on your test. If you cannot answer them all, reread Section 3.

We know your time is *valuable*

GOONLINE
dmv.ca.gov/online

- Renew driver's license and vehicle registration
- Replace sticker or registration
- Change address
- Request driver's record
- Order vehicle record
- And more

SECTION 4: TRANSPORTING PASSENGERS SAFELY

THIS SECTION COVERS

- 4.1 – Vehicle Inspection
- 4.2 – Loading and Trip Start
- 4.3 – On the Road
- 4.4 – After-Trip Vehicle Inspection
- 4.5 – Prohibited Practices
- 4.6 – Use of Brake-Door Interlocks

Passenger vehicle drivers must have a CDL with a “P” endorsement if they drive a vehicle designed to transport more than 10 persons, including the driver.

A passenger transportation vehicle includes, but is not limited to, a bus, farm labor vehicle, or general public paratransit vehicle when the vehicle is designed, used, or maintained to carry more than 10 passengers, including the driver, for hire or for profit, or by any nonprofit organization or group.

If you take a driving test in a van designed, used, or maintained to carry 15 persons or less, including the driver, you will be restricted to driving a 15-passenger or less small-size bus.

To get the endorsement, you must pass a knowledge test on Sections 2 and 4 of this handbook. If your bus has air brakes, you must pass a knowledge test on Section 5. You must also pass the skills tests required for the class of vehicle you drive.

A CLP holder with a “P” and/or an “S” endorsement is prohibited from operating a CMV with passengers, other than federal/state auditors and inspectors, test examiners, other trainees, and the accompanying CDL holder (FMCSR §383.25).

4.1 – VEHICLE INSPECTION

Before driving your bus, you must be sure it is safe. You must review the inspection report made by the previous driver. Only if defects reported earlier have been certified as repaired or repairs not needed, should you sign the previous driver’s report. This is your certification that the defects reported earlier have been fixed.

See Section 11 for inspection information and guidelines. Memory aids are shown at the end of Section 11. You may only use one of these when you take your CDL vehicle inspection test for your CDL at DMV. The memory aid cannot include instructions on how to perform the vehicle inspection test. Refer to Section 5 for Air Brake information.

4.1.1 – Vehicle Systems

Make sure these things are in good working order before driving:

- Service brakes, including air hose couplings (if your bus has a trailer or semitrailer).
- Parking brake.
- Steering mechanism.
- Lights and reflectors.
- Tires (front wheels must not have recapped or regrooved tires).
- Horn.
- Windshield wiper or wipers.
- Rear-vision mirror or mirrors.
- Coupling devices (if present).
- Wheels and rims.
- Emergency equipment.
 - Make sure the bus has fire extinguishers and emergency reflectors required by law.
 - The bus must have spare electrical fuses, unless equipped with circuit breakers.

4.1.2 – Access Doors and Panels

As you check the outside of the bus, close any open emergency exits. Also, close any open access panels (for baggage, restroom service, engine, etc.) before driving.

4.1.3 – Bus Interior

People sometimes damage unattended buses. Always check the interior of the bus before driving to ensure rider safety. Aisles and stairwells should always be clear. The following parts of your bus must be in safe working condition:

- Each handhold and railing.
- Floor covering.
- Signaling devices, including the restroom emergency buzzer, if the bus has a restroom.
- Emergency exit handles.

The seats must be safe for riders. All seats must be securely fastened to the bus.

Check the emergency exits for ease of operation, correct markings, and ensure any required buzzers or devices work properly.

Never drive with an open emergency exit door or window. The “Emergency Exit” sign on an emergency door must be clearly visible. If there is a red emergency door light, it must work. Turn it on at night or any other time you use your outside lights.

In the passenger compartment of a farm labor vehicle, all cutting tools or tools with sharp edges must be placed in a covered container. All other tools, equipment, or materials carried in the passenger compartment shall be secured to the body of the vehicle. The driver and all passengers must wear seat belts.

4.1.4 – Roof Hatches

You may lock some emergency roof hatches in a partly open position for fresh air. Do not leave them open as a regular practice. Keep in mind the bus’s higher clearance while driving with them open.

4.1.5 – Use Your Seatbelt!

The driver’s seat should have a seat belt. Always use it for safety.

4.2 – LOADING AND TRIP START

Do not allow riders to leave carry-on baggage in a doorway or aisle. There should be nothing in the aisle that might trip other riders. Secure baggage and freight in ways that avoid damage and:

- Allow the driver to move freely and easily.
- Allow riders to exit by any window or door in an emergency.
- Protect riders from injury if carry-ons fall or shift.

4.2.1 – Hazardous Materials

Watch for cargo or baggage containing HazMat. Most HazMat cannot be carried on a bus.

The Federal Hazardous Class Definitions Table shows which materials are hazardous. They pose a risk to health, safety, and property during transportation. The rules require shippers to mark containers of HazMat with the material’s name, ID number, and hazard label. There are 9 different 4 inch, diamond-shaped hazard labels. See Figure 4.1. Watch for the diamond-shaped labels. Do not transport any HazMat unless you are sure the rules allow it.

HAZARD CLASS DEFINITIONS		
Class	Class Name	Example
1	Explosives	Ammunition, Dynamite, Fireworks
2	Gases	Propane, Oxygen, Helium
3	Flammable	Gasoline, Acetone
4	Flammable Solids	Matches, Fuses
5	Oxidizers	Ammonium Nitrate, Hydrogen Peroxide
6	Poisons	Pesticides, Arsenic
7	Radioactive	Uranium, Plutonium
8	Corrosives	Hydrochloric Acid, Battery Acid
9	Miscellaneous Hazardous Materials	Formaldehyde, Asbestos
None	ORM-D (Other Regulated Material-Domestic)	Hair Spray or Charcoal
None	Combustible Liquids	Fuel Oils, Lighter Fluid

Figure 4.1

4.2.2 – Forbidden Hazardous Materials

Buses may carry small-arms ammunition labeled ORM-D, emergency hospital supplies, and drugs. You can carry small amounts of other HazMat if the shipper cannot send them any other way. Buses must never carry:

- Division 2.3 poison gas, liquid Class 6 poison, tear gas, or irritating material.
- More than 100 pounds of solid Class 6 poisons.
- Explosives in the space occupied by people, except small-arms ammunition.
- Labeled radioactive materials in the space occupied by people.
- More than 500 pounds total of allowed HazMat, and no more than 100 pounds of any 1 class.

Riders sometimes board a bus with an unlabeled HazMat. Do not allow riders to carry on common hazards such as car batteries or gasoline.

Oxygen medically prescribed for, in the possession of a passenger, and in a container designed for personal use is allowed.

Wheelchairs transported on buses (except school buses) must have brakes or other mechanical means of holding still while it is raised or lowered on the wheelchair platform. Batteries must be spill resistant and securely attached to the wheelchair. Wheelchairs may not use flammable fuel. School bus wheelchair regulations are in CCR, Title 13 §1293.

4.2.3 – Standee Line

No rider may stand forward of the rear of the driver’s seat. Buses designed to allow standing must have a 2-inch line on the floor or some other means of showing riders where they cannot stand. This is called the standee line. All standing riders must stay behind it.

4.2.4 – At Your Destination

When arriving at the destination or intermediate stops, announce:

- The location.
- Reason for stopping.
- Next departure time.
- Bus number.

Remind riders to take carry-ons with them if they get off the bus. If the aisle is on a lower level than the seats, remind riders of the step-down. It is best to tell them before coming to a complete stop.

Charter bus drivers should not allow riders on the bus until departure time. This will help prevent theft or vandalism of the bus.

4.2.5 – Loading and Unloading

Bus drivers need to consider passenger safety during loading and unloading. Always ensure your passengers are safely on the bus before closing the door(s) and pulling away. Allow passengers enough time to sit down or brace themselves before departing. Starting and stopping should be as smooth as possible to avoid rider injury.

4.2.6 – Animals

Transporting animals is prohibited except for certified service, guide, or signal dogs used by physically challenged passengers (*California Civil Code (CCC) §54.2*).

4.3 – ON THE ROAD

4.3.1 – Passenger Supervision

Many charter and intercity carriers have passenger comfort and safety rules. Mention rules about smoking, drinking, or electronic devices at the start of the trip. Explaining the rules at the start will help to avoid trouble later on.

While driving, scan the interior of your bus, as well as the road ahead, to the sides, and to the rear. You may have to remind riders about rules, or to keep their arms and heads inside the bus.

4.3.2 – At Stops

Riders can stumble when getting on or off and when the bus starts or stops. Caution riders to watch their step when leaving the bus. Wait for them to sit down or brace themselves before starting. Starting and stopping should be as smooth as possible to avoid rider injury.

Occasionally, you may have a drunk or disruptive rider. You must ensure this rider's safety, as well as that of others. Do not discharge such riders where it would be unsafe for them. It may be safer at the next scheduled stop or a well-lit area where there are other people. Many carriers have guidelines for handling disruptive riders.

4.3.3 – Common Accidents

Most Common Bus Accidents. Bus accidents often happen at intersections. Use caution, even if a signal or stop sign controls other traffic. School and mass transit buses sometimes scrape off mirrors or hit passing vehicles when pulling out from a bus stop. Remember the clearance your bus needs, and watch for poles and tree limbs at stops. Know the size of the gap your bus needs to accelerate and merge with traffic. Wait for the gap to open before leaving the stop. Never assume other drivers will brake to give you room when you signal or start to pull out.

4.3.4 – Speed on Curves

Accidents occurring on curves that kill people and destroy buses, result from excessive speed, often when rain or snow has made the road slippery. Every banked curve has a safe "design speed." In good weather, the posted speed is safe for cars but it may be too fast for many buses. With good traction, the bus may roll over. With poor traction, it may slide off the curve. Reduce speed for curves! If your bus leans toward the outside on a banked curve, you are driving too fast.

4.3.4(a) – Using Your Mirrors

When you use your mirrors while driving on the road, check them quickly. Look back and forth regularly as part of your scan for potential hazards. Do not focus on the mirrors for too long. Otherwise, you will travel quite a distance without knowing what is happening ahead.

Many buses have convex mirrors that show a wider area than flat mirrors. This is often helpful. Remember, these mirrors make things seem smaller and farther away than they really are.

4.3.5 – Railroad-Highway Crossing/Stops

Stop at Railroad Crossings.

- Stop your bus between 15 and 50 feet before railroad crossings.
- Listen and look in both directions for trains. You should open your forward door if it improves your ability to see or hear an approaching train.
- Before crossing after a train has passed, make sure there is not another train coming in the other direction on other tracks.
- If your bus has a manual transmission, never change gears while crossing the tracks.
- You do not have to stop, but must slow down and carefully check for other vehicles:
 - At railroad tracks which run alongside and on the roadway within a business or residence district.
 - At streetcar crossings.
 - Where a peace officer or flagman is directing traffic.
 - If a traffic signal is green.
 - At crossings marked as “exempt” or “abandoned.”

4.3.6 – Drawbridges

Stop at Drawbridges. Stop at drawbridges that do not have a signal light or traffic control attendant. Stop at least 50 feet before the draw of the bridge. Look to make sure the draw is completely closed before crossing. You do not need to stop, but must slow down and make sure it is safe, when:

- There is a traffic light showing green.
- The bridge has an attendant or traffic officer who controls traffic whenever the bridge opens.

4.4 – AFTER-TRIP VEHICLE INSPECTION

Inspect your bus at the end of each shift. If you work for an interstate carrier, you must complete a written inspection report for each bus driven. The report must specify each bus and list any defect that would affect safety or result in a breakdown. If there are no defects, the report should say so.

Riders sometimes damage safety-related parts such as handholds, seats, emergency exits, and windows. If you report this damage at the end of a shift, mechanics can make repairs before the bus goes out again. Mass transit drivers should also make sure passenger signaling devices and brake-door interlocks work properly.

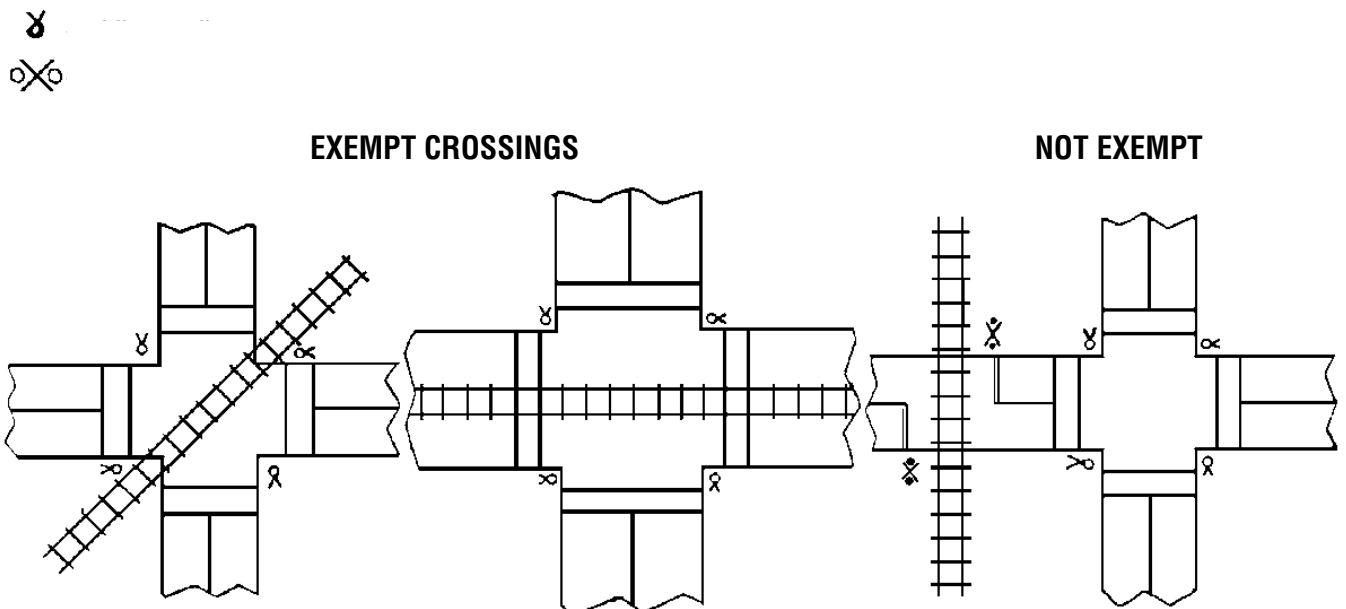

Figure 4-A

4.5 – PROHIBITED PRACTICES

Avoid fueling your bus with riders on board unless absolutely necessary. Never refuel in a closed building with riders on board.

Do not talk with riders, or engage in any other distracting activity, while driving.

Do not tow or push a disabled bus with riders aboard the vehicle, unless getting off would be unsafe. Only tow or push the bus to the nearest safe spot to discharge passengers. Follow your employer's guidelines on towing or pushing disabled buses.

4.6 – USE OF BRAKE-DOOR INTERLOCKS

Urban mass transit coaches may have a brake and accelerator interlock system. The interlock applies the brakes and holds the throttle in the idle position when the rear door is open. The interlock releases when you close the rear door. Do not use this safety feature in place of the parking brake.

SECTION 4

Test Your Knowledge

1. Name some things to check in the interior of a bus during a vehicle inspection.
2. What are some HazMat you can transport by bus?
3. What are some HazMat you cannot transport by bus?
4. What is a standee line?
5. Does it matter where you make a disruptive passenger get off the bus?
6. How far from a railroad crossing should you stop?
7. When must you stop before crossing a drawbridge?
8. Describe from memory the “prohibited practices” listed in this handbook.
9. The rear door of a transit bus has to be open to put on the parking brake. True or False?

These questions may be on your test. If you cannot answer them all, reread Section 4.

SECTION 5: AIR BRAKES

THIS SECTION COVERS

- 5.1 – Parts of an Air Brake System
- 5.2 – Dual Air Brake
- 5.3 – Inspecting Air Brake Systems
- 5.4 – Using Air Brakes

This section tells you about air brakes. If you want to drive a truck, bus, or pull a trailer with air brakes, you need to read this section. If you want to pull a trailer with air brakes, you also need to read Section 6: Combination Vehicles in this handbook.

Air brakes use compressed air to make the brakes work. Air brakes are a good and safe way of stopping large and heavy vehicles, but the brakes must be well maintained and used properly.

Air brakes are really 3 different braking systems: service brake, parking brake, and emergency brake. The:

- **Service brake system** applies and releases the brakes when you use the brake pedal during normal driving.
- **Parking brake system** applies and releases the parking brakes when you use the parking brake control.
- **Emergency brake system** uses parts of the service and parking brake systems to stop the vehicle in a brake system failure.

CDL Air Brake Requirements. For CDL purposes, a vehicle’s air brake system must meet the above definition and contain the following, which will be checked during the vehicle inspection test:

- Air gauges.
- Low pressure warning device(s).

If the vehicle you use for your road test does not have these components, your vehicle will not be considered as having an air brake system and you will have a “No Air Brakes” (“L”) restriction on your CDL.

NOTE: A full service brake application must deliver to all brake chambers not less than 90 percent of the air reservoir pressure remaining with the brakes applied (CVC §26502).

The parts of these systems are discussed in greater detail in the following paragraphs.

5.1 – PARTS OF AN AIR BRAKE SYSTEM

There are many parts to an air brake system. You should know about the parts discussed here.

5.1.1 – Air Compressor

The air compressor pumps air into the air storage tanks (reservoirs). The air compressor is connected to the engine through gears or a v-belt. The compressor may be air cooled or cooled by the engine cooling system. It may have its own oil supply or be lubricated by engine oil. If the compressor has its own oil supply, check the oil level before driving.

5.1.2 – Air Compressor Governor

The governor controls when the air compressor will pump air into the air storage tanks. When air tank pressure rises to the “cut-out” level (around 125 pounds psi), the governor stops the compressor from pumping air. When the tank pressure falls to the “cut-in” pressure (around 100 psi), the governor allows the compressor to start pumping again.

5.1.3 – Air Storage Tanks

Air storage tanks are used to hold compressed air. The number and size of air tanks varies among vehicles. The tanks will hold enough air to allow the brakes to be used several times, even if the compressor stops working.

5.1.4 – Air Tank Drains

Compressed air usually has some water and some compressor oil in it, which is bad for the air brake system. The water can freeze in cold weather and cause brake failure. The water and oil tend to collect in the bottom of the air tank. Be sure that you drain the air tanks completely. Each air tank is equipped with a drain valve in the bottom. There are 2 types:

- **Manual**—operated by turning a quarter turn or pulling a cable. You must drain the tanks yourself at the end of each day of driving. See Figure 5.1.
- **Automatic**—the water and oil are automatically expelled. These tanks may be equipped for manual draining as well.

Automatic air tanks are available with electric heating devices. These help prevent freezing of the automatic drain in cold weather.

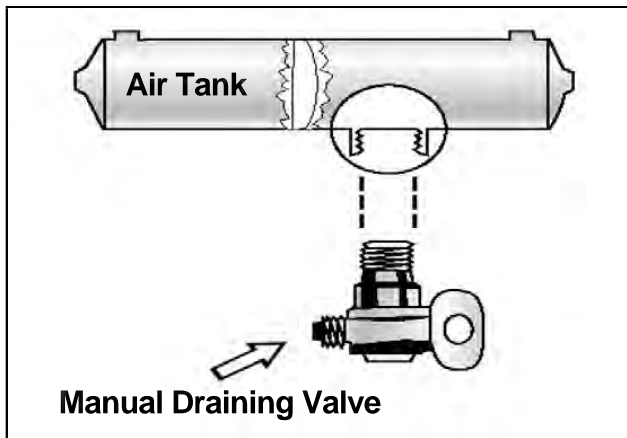

Figure 5.1

5.1.5 – Alcohol Evaporator

Some air brake systems have an alcohol evaporator to put alcohol into the air system. This helps to reduce the risk of ice in air brake valves and other parts during cold weather. Ice inside the system can make the brakes stop working.

Check the alcohol container and fill up as necessary (every day during cold weather). Daily air tank drainage is still needed to get rid of water and oil (unless the system has automatic drain valves).

5.1.6 – Safety Valve

A safety relief valve is installed in the first tank the air compressor pumps air to. The safety valve protects the tank and the rest of the system from too much pressure. The valve is usually set to open at 150 psi. If the safety valve releases air, something is wrong. Have the fault fixed by a mechanic.

5.1.7 – Brake Pedal

You engage the brakes by pushing down the brake pedal (also called a foot valve or treadle valve). Pushing the pedal down harder applies more air pressure. Letting up on the brake pedal reduces the air pressure and releases the brakes. Releasing the brakes lets some compressed air go out of the system, so the air pressure in the tanks is reduced. It must be made up by the air compressor. Pressing and releasing the pedal unnecessarily can let air out faster than the compressor can replace it. If the pressure gets too low, the brakes will not work.

5.1.8 – Foundation Brakes

Foundation brakes are used at each wheel. The most common type is the S-cam drum brake. The parts of the brake are discussed below.

Brake Drums, Shoes, and Linings. Brake drums are located on each end of the vehicle's axles. The wheels are bolted to the drums. The braking mechanism is inside the drum. To stop, the brake shoes and linings are pushed against the inside of the drum. This causes friction, which slows the vehicle (and creates heat). The heat a drum can take without damage depends on how hard and how long the brakes are used. Too much heat can make the brakes stop working.

S-cam Brakes. When you push the brake pedal, air is let into each brake chamber. Air pressure pushes the rod out, moving the slack adjuster, thus twisting the brake camshaft. This turns the S-cam (it is shaped like the letter "S"). The S-cam forces the brake shoes away from one another and presses them against the inside of the brake drum. When you release the brake pedal, the S-cam rotates back and a spring pulls the brake shoes away from the drum, letting the wheels roll freely again. See Figure 5.2.

CamLaster. The CamLaster brake has 2 key design differences over traditional S-cam brakes.

One feature is a completely internal adjustment system which is designed to continually keep the brake in proper adjustment. S-cam brakes, on the other hand, require an external slack adjuster. The second feature is a unique cam design that applies the brake shoe. Unlike a standard drum brake that has either a single or double anchor-pin brake, the CamLaster slides the shoes down an inclined ramp on a cam to evenly contact the brake drum.

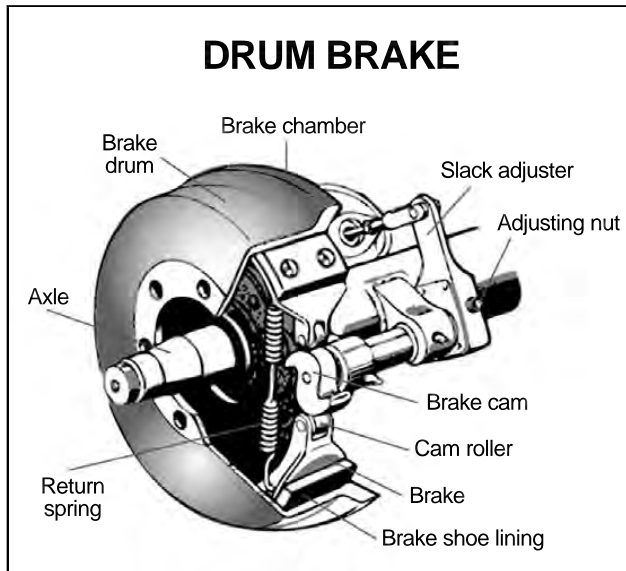

Figure 5.2

Wedge Brakes. In this type of brake, the brake chamber push rod pushes a wedge directly between the ends of 2 brake shoes. This shoves them apart and against the inside of the brake drum. Wedge brakes may have a single brake chamber or 2 brake chambers that push wedges in at both ends of the brake shoes. Wedge type brakes may be self-adjusting or may require manual adjustment.

Disc Brakes. In air-operated disc brakes, air pressure acts on a brake chamber and slack adjuster, like S-cam brakes. But instead of the S-cam, a “power screw” is used. The pressure of the brake chamber on the slack adjuster turns the power screw. The power screw clamps the disc or rotor between the brake lining pads of a caliper, similar to a large c-clamp.

Wedge brakes and disc brakes are less common than S-cam brakes.

5.1.9 – Supply Pressure Gauges

All vehicles with air brakes have a pressure gauge connected to the air tank. If the vehicle has a dual air brake system, there will be a gauge for each half of the system (or a single gauge with 2 needles). Dual systems will be discussed later. These gauges tell you how much pressure is in the air tanks.

5.1.10 – Application Pressure Gauge

This gauge shows how much air pressure you are applying to the brakes. (This gauge is not on all vehicles.) Increasing application pressure to hold the same speed means the brakes are fading. You should slow down and use a lower gear. Brakes that are of adjustment, air leaks, or mechanical problems can also cause the need for increased pressure.

5.1.11 – Low Air Pressure Warning

A low air pressure warning signal is required on vehicles with air brakes. A warning signal you can see must come on when the air pressure in the tanks falls between 55 and 75 psi (or 1/2 the compressor governor cutout pressure on older vehicles). The warning is usually a red light. A buzzer may also come on.

Another type of warning is the “wig wag.” This device drops a mechanical arm into your view when the pressure in the system drops between 55 and 75 psi. An automatic wig wag will rise out of your view when the pressure in the system goes above 55 and 75 psi. The manual reset type must be placed in the “out of view” position manually. It will not stay in place until the pressure in the system is above 55 psi.

On large buses, it is common for the low pressure warning devices to signal at 80–85 psi.

5.1.12 – Stop Light Switch

Drivers behind you must be warned when you put your brakes on. The air brake system does this with an electric switch that works by air pressure. The switch turns on the brake lights when you put on the air brakes.

5.1.13 – Front Brake Limiting Valve

Some vehicles made before 1975 have a front brake limiting valve and a control in the cab. The control is usually marked “normal” and “slippery.” When you put the control in the “slippery” position, the limiting valve cuts the “normal” air pressure to the front brakes by half. Limiting valves were used to reduce the chance of the front wheels skidding on slippery surfaces. However, they actually reduce the stopping power of the vehicle. Front wheel braking is good under all conditions. Tests have shown front wheel skids from braking are not likely even on ice. Make sure the control is in the “normal” position to have normal stopping power.

Many vehicles have automatic front wheel limiting valves. They reduce the air to the front brakes except when the brakes are put on very hard (60 psi or more application pressure). The driver cannot control these valves.

5.1.14 – Spring Brakes

All trucks, truck tractors, and buses must be equipped with emergency brakes and parking brakes. They must be held on by mechanical force (because air pressure can eventually leak away). Spring brakes are usually used to meet these needs. Powerful springs are held back by air pressure when driving. If the air pressure is removed, the springs put on the brakes. A parking brake control in the cab allows the driver to let the air out of the spring brakes. This lets the springs put the brakes on. A leak in the air brake system, which causes all the air to be lost, will also cause the springs to put on the brakes.

Tractor and straight truck spring brakes will come fully on when air pressure drops to a range of 20 to 45 psi (typically 20 to 30 psi). Do not wait for the brakes to come on automatically. When the low air pressure warning light and buzzer first come on, bring the vehicle to a safe stop right away, while you can still control the brakes.

The braking power of spring brakes depends on the brakes being in adjustment. If the brakes are not adjusted properly, neither the regular brakes nor the emergency/parking brakes will work right.

5.1.15 – Parking Brake Controls

In newer vehicles with air brakes, you put on the parking brakes using a diamond-shaped, yellow, push-pull control knob. You pull the knob out to put the parking brakes (spring brakes) on, and push it in to release them. On older vehicles, the parking brakes may be controlled by a lever. Use the parking brakes whenever you park.

Caution. Never push the brake pedal down when the spring brakes are on. If you do, the brakes could be damaged by the combined forces of the springs and the air pressure. Many brake systems are designed so this will not happen. Not all systems are set up that way, and those that are may not always work. It is much better to develop the habit of not pushing the brake pedal down when the spring brakes are on.

Modulating Control Valves. In some vehicles a control handle on the dash board may be used to apply the spring brakes gradually. This is called a modulating valve. It is spring-loaded so you have a feel for the braking action. The more you move the control lever, the harder the spring brakes come on. They work this way so you can control the spring brakes if the service brakes fail. When parking a vehicle with a modulating control valve, move the lever as far as it will go and hold it in place with the locking device.

Dual Parking Control Valves. When main air pressure is lost, the spring brakes come on. Some vehicles, such as buses, have a separate air tank which can be used to release the spring brakes. This is so you can move the vehicle in an emergency. One of the valves is a push-pull type used to put on the spring brakes for parking. The other valve is spring loaded in the “out” position. When you push the control in, air from the separate air tank releases the spring brakes so you can move. When you release the button, the spring brakes come on again. There is only enough air in the separate tank to do this a few times. Therefore, plan carefully when moving. Otherwise, you may be stopped in a dangerous location when the separate air supply runs out. See Figure 5.3.

TRACTOR PROTECTION VALVE & EMERGENCY TRAILER BRAKE OPERATION

Tractor protection valve

- Provides air supply
- Closes automatically if air supply drops when driving

The parking brakes, when applied, close the tractor protection valve and set the spring brakes at the same time.

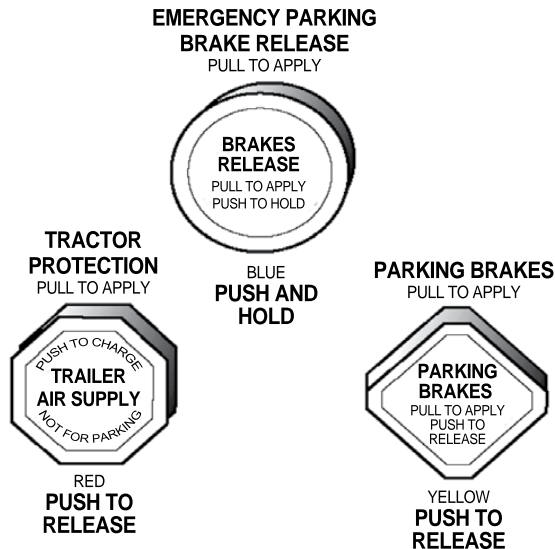

Figure 5.3

5.1.16 – Anti-lock Braking Systems

Truck tractors with air brakes built on or after March 1, 1997, and other air brakes vehicles (trucks, buses, trailers, and converter dollies) built on or after March 1, 1998, are required to be equipped with anti-lock brakes. Many commercial vehicles built before these dates have been voluntarily equipped with ABS. Check the certification label for the date of manufacture to determine if your vehicle is equipped with ABS. ABS is a computerized system that keeps your wheels from locking up during hard brake applications.

- Vehicles with ABS have yellow malfunction lamps to tell you if something is not working.
- Tractors, trucks, and buses will have yellow ABS malfunction lamps on the instrument panel.

- Trailers will have yellow ABS malfunction lamps on the left side, either on the front or rear corner. Dollies manufactured on or after March 1, 1998, are required to have a lamp on the left side.

On newer vehicles, the malfunction lamp comes on at start-up for a bulb check, and then goes out quickly. On older systems, the lamp could stay on until you are driving over 5 mph.

- If the lamp stays on after the bulb check, or goes on once you are under way, you may have lost ABS control at one or more wheels.
- In the case of towed units manufactured before it was required by DOT, it may be difficult to tell if the unit is equipped with ABS. Look under the vehicle for the ECU and wheel speed sensor wires coming from the back of the brakes.
- ABS is an addition to your normal brakes. It does not decrease or increase your normal braking capability. ABS only activates when wheels are about to lock up.
- ABS does not necessarily shorten your stopping distance, but it does help you keep the vehicle under control during hard braking.

SUBSECTION 5.1

Test Your Knowledge

1. Why must air tanks be drained?
2. What is a supply pressure gauge used for?
3. All vehicles with air brakes must have a low air pressure warning signal. True or False?
4. What are spring brakes?
5. Front wheel brakes are good under all conditions. True or False?
6. How do you know if your vehicle is equipped with anti-lock brakes?

These questions may be on your test. If you cannot answer them all, reread Subsection 5.1.

AIR BRAKE SYSTEM COMPONENTS AND LOCATION (SINGLE CIRCUIT SYSTEM)

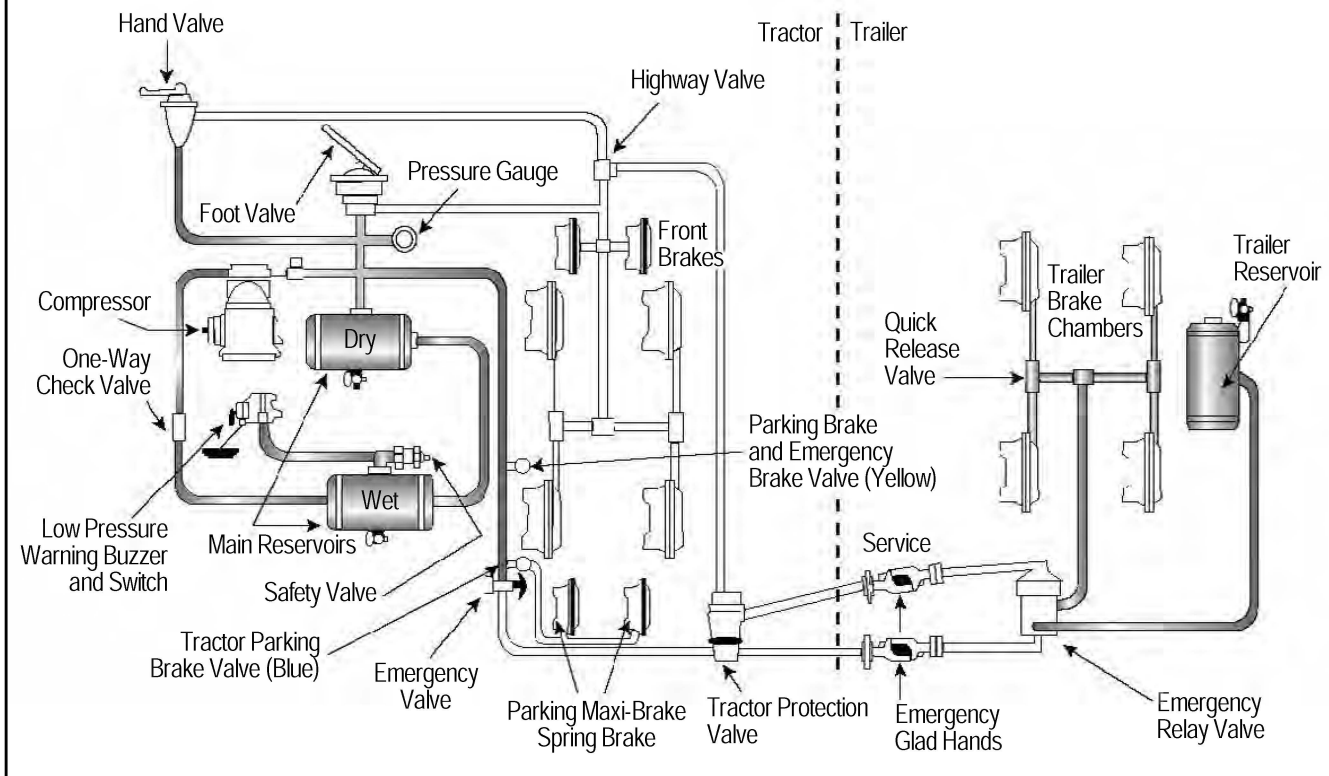

Figure 5.4

5.2 – DUAL AIR BRAKE

Most heavy-duty vehicles use dual air brake systems for safety. A dual air brake system has 2 separate air brake systems, which use a single set of brake controls. Each system has its own air tanks, hoses, lines, etc. One system typically operates the regular brakes on the rear axle or axles. The other system operates the regular brakes on the front axle (and possibly one rear axle). Both systems supply air to the trailer (if there is one). The first system is called the “primary” system. The other is called the “secondary” system. See Figure 5.4.

Before driving a vehicle with a dual air system, allow time for the air compressor to build up a minimum of 100 psi pressure in both the primary and secondary systems. Watch the primary and secondary air pressure gauges (or needles, if the system has 2 needles in one gauge). Pay attention to the low air pressure warning light and buzzer. The warning light and buzzer should shut off when air pressure in both systems rises to a value set by the manufacturer. This value must be greater than 55 psi.

The warning light and buzzer should come on before the air pressure drops below 55 psi in either system. If this happens while driving, you should stop right away and safely park the vehicle. If one air system is very low on pressure, either the front or rear brakes will not be operating fully. This means it will take you longer to stop. Bring the vehicle to a safe stop, and have the air brakes system fixed.

One-Way Check Valve

This device allows air to flow in one direction only. All air tanks on air-brake vehicles must have a check valve located between the air compressor and the first reservoir (CVC §26507). The check valve keeps air from going out if the air compressor develops a leak.

5.3 – INSPECTING AIR BRAKE SYSTEMS

You should use the basic 7-step inspection procedure described in Section 2 to inspect your vehicle. There is more to inspect on a vehicle with air brakes than one without them. These components are discussed below, in the order that they fit into the 7-step method.

5.3.1 – During Step 2 Engine Compartment Checks

Check the air compressor drive belt (if the compressor is belt-driven). If the air compressor is belt-driven, check the condition and tightness of the belt. It should be in good condition.

5.3.2 – During Step 5 Walk Around Inspection

Check slack adjusters on S-cam brakes. Park on level ground and chock the wheels to prevent the vehicle from moving. Release the parking brakes so you can move the slack adjusters. Use gloves and pull hard on each slack adjuster that you can reach. If a slack adjuster moves more than about one inch where the push rod attaches to it, it probably needs adjustment. Adjust it or have it adjusted. Vehicles with too much brake slack can be very hard to stop. Out-of-adjustment brakes are the most common problem found in roadside inspections. Be safe. Check the slack adjusters.

All vehicles built since 1994 have automatic slack adjusters. Even though automatic slack adjusters adjust themselves during full brake applications, they must be checked.

Automatic adjusters should not have to be manually adjusted except when performing maintenance on the brakes and during installation of the slack adjusters. In a vehicle equipped with automatic adjusters, when the pushrod stroke exceeds the legal brake adjustment limit, it is an indication that a mechanical

problem exists in the adjuster itself, a problem exists with the related foundation brake components, or the adjuster was improperly installed.

The manual adjustment of an automatic adjuster to bring a brake pushrod stroke within legal limits is generally masking a mechanical problem and is not fixing it. Further, routine adjustment of most automatic adjusters will likely result in premature wear of the adjuster itself. It is recommended that when brakes equipped with automatic adjusters are found to be out of adjustment, the driver takes the vehicle to a repair facility as soon as possible to have the problem corrected. The manual adjustment of automatic slack adjusters is dangerous because it may give the driver a false sense of security regarding the effectiveness of the braking system.

The manual adjustment of an automatic adjuster should only be used as a temporary measure to correct the adjustment in an emergency situation. It is likely the brake will soon be back out of adjustment since this procedure usually does not fix the underlying adjustment problem.

Note: Automatic slack adjusters are made by different manufacturers and do not all operate the same. Therefore, the specific manufacturer's service manual should be consulted prior to troubleshooting a brake adjustment problem.

Check Brake Drums (or Discs), Linings, and Hoses

Brake drums (or discs) must not have cracks longer than 1/2 the width of the friction area. Linings (friction material) must not be loose or soaked with oil or grease and must not be worn dangerously thin (less than 1/4 inch). Mechanical parts must be in place, not broken, or missing. Check the air hoses connected to the brake chambers to make sure they are not cut or worn due to rubbing.

5.3.3 – Step 7: Final Air Brake Check

All air brake system tests in this section are considered important and each can be considered critical parts of the in-cab air brakes tests. The items marked with an asterisk (*) in this section are required for testing purposes during the vehicle inspection portion of the CDL skills test. They may be performed in any order as long as they are performed correctly and effectively. If these items are not demonstrated and the parameters for each test are not verbalized correctly, it is considered an automatic failure of the vehicle inspection portion of the skills test.

Do the following checks instead of the hydraulic brake check shown in Section 2, Step 7: Check Brake System.

5.3.3.1 – Applied Leakage Test (1-minute hold):*

To perform this test, the driver must start with the engine running and with the air pressure built to governor cut-out (120–140 psi or another level specified by the manufacturer). The driver identifies when cut-out occurred, shuts off the engine, chocks the wheels if necessary, releases the parking brake (all vehicles) and tractor protection valve (combination vehicle), and fully applies the foot brake. The driver then holds the foot brake for 1 minute after stabilization of the air gauge. The driver checks the air gauge to see that the air pressure drops no more than 3 pounds in one minute (single vehicle) or 4 pounds in 1 minute (combination vehicle) and listens for air leaks. The driver must identify how much air the system lost and verbalize the maximum air loss rate allowed for the representative vehicle being tested.

NOTE: For a Class A combination vehicle, if the power unit is equipped with air brakes and the trailer is equipped with electric/surge brakes, the pressure drop should be no more than 3 psi.

- 3 psi for single vehicles.
- 4 psi for a combination of 2 vehicles.
- 6 psi for a combination of 3 or more vehicles.

IMPORTANT: The maximum air loss rate for a combination of 2 or more vehicles is 3 psi if the towed vehicles are not equipped with air brakes.

An air loss greater than those listed above, indicates a problem in the braking system and repairs are needed before operating the vehicle. If the air loss is too much, check for air leaks and fix any that are identified.

NOTE: For testing purposes, you must be able to demonstrate this test and verbalize the allowable air loss for your vehicle. For testing purposes, identify if the air loss rate is too much.

5.3.3.2 – Low Air Warning Device*

To perform this test the vehicle must have enough air pressure so the low-pressure warning signal is off. The engine maybe on or off; however, the key must be in the “on” or “battery charge” position. Next, the driver begins fanning off the air pressure by rapidly applying and releasing the foot brake. Low-air warning devices (buzzer, light, and flag) must activate before air pressure drops below 55 psi or the level specified by the manufacturer. The driver must indicate the approximate pressure when the device gave warning and identify the parameter at which this must occur; no lower than 55 psi. See Figure 5.5.

For testing purposes, identify and verbalize the pressure at which the low air pressure warning signal activates and identify the parameter(s) at which this should occur. On large buses, it is common for low-pressure warning devices to signal at 80–85 psi. If testing in a large bus, identify the parameter(s) mentioned above (55–75 psi) and inform the examiner that your vehicle’s low-pressure warning devices are designed to activate at a higher pressure.

If the warning signal does not work, you could lose air pressure and not know it. This could cause sudden emergency braking in a single-circuit air system. In dual systems, the stopping distance will be increased. Only limited braking can be done before the spring brakes come on.

NOTE: Farm labor vehicles and Type I school buses must be equipped with both an audible and visible type warning device.

* Required for testing purposes during the vehicle inspection portion of the CDL skills test.

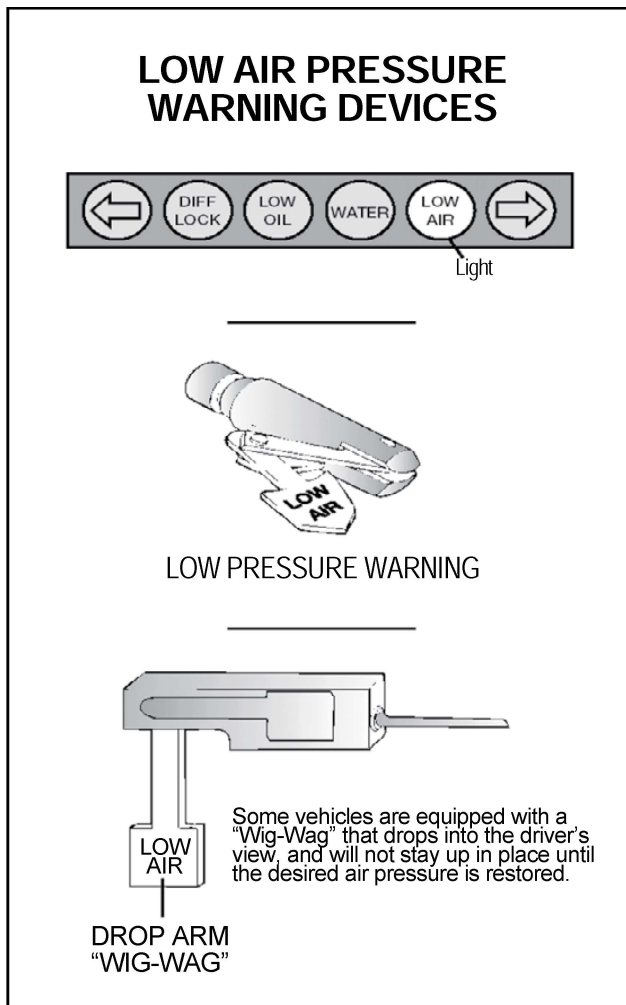

Figure 5.5

5.3.3.3 – Spring Brake Test:*

To perform this test, the parking brake (all vehicles) and tractor protection valve (combination vehicles) must be released; (engine running or not) as the driver fans off the air pressure. Normally between 20-45 psi (or the level specified by the manufacturer), on a tractor-trailer combination vehicle, the tractor protection valve and parking brake valve should close (pop out). On other combination vehicle types and single vehicle types, the parking brake valve should close (pop out). The driver must identify and verbalize the approximate pressure at which the brake(s) activated.

NOTE: The parking brake valve will not pop out on buses that are equipped with an emergency park brake air reservoir (tank). If your bus is equipped with an emergency park brake air tank, you must perform the spring brake test for triple reservoir vehicles to check the automatic actuation of the spring brakes.

Spring Brake Test for Triple Reservoir Vehicles

If the parking brake valve does not pop out when the air pressure has been reduced to approximately 20 psi, you must demonstrate that the spring brakes have activated. To do this, you must:

- Remove the wheel chocks, if necessary.
- Leave the parking brake valve in the open (released) position.
- With the engine running, put the vehicle in a forward gear and attempt to drive forward.

The spring brakes should drag and prevent the vehicle from easily moving forward. If the spring brakes do not prevent the vehicle from easily moving forward, your road test will be postponed.

NOTE: This test must only be performed on single vehicles designed with an isolated parking brake reservoir. Do not perform this test on combination vehicles.

Check the Rate of Air Pressure Buildup

To perform this test, the engine must be running at normal operating idle, typically 600–900 rpms. Observe the air gauge to determine if the pressure builds at the proper rate. For dual air systems, the pressure should build from approximately 85 to 100 psi within 45 seconds. For single air systems (in pre-1975 vehicles), the pressure should build from approximately 50 to 90 psi within 3 minutes.

For testing purposes, you must verbalize the parameters of the test and identify if the vehicle met the appropriate standards.

* Required for testing purposes during the vehicle inspection portion of the CDL skills test.

Test Air Leakage Rate

There are 3 tests as follows:

Static Leakage Test

With a basically fully-charged air system (within the effective operating range for the compressor), turn off the engine, release all brakes, and let the system settle (air gauge needle stops moving). Time for 1 minute. The air pressure should not drop more than:

- 2 psi for single vehicles.
- 3 psi for a combination of 2 vehicles.
- 5 psi for a combination of 3 or more vehicles.

IMPORTANT: The maximum air loss rate for a combination of 2 or more vehicles is 2 psi if the towed vehicles are not equipped with air brakes.

An air loss greater than those listed above, indicate a problem in the braking system and repairs are needed before operating the vehicle.

Test Parking Brake

Fasten your seat belt. Set the parking brake, and gently pull against it in a low gear to test that the parking brake will hold.

Test Service Brakes

Wait for normal air pressure, release the parking brake, move the vehicle forward slowly (about 5 mph), and apply the brakes firmly using the brake pedal. Note any vehicle “pulling” to one side, unusual feel, or delayed stopping action.

This test may show you problems, which you otherwise would not know about until you needed the brakes on the road.

SUBSECTIONS 5.2 AND 5.3

Test Your Knowledge

7. What is a dual air brake system?
8. What are the slack adjusters?
9. How can you check slack adjusters?
10. How can you test the low pressure warning signal?
11. How can you check the spring brakes come on automatically?
12. What are the maximum leakage rates?

These questions may be on your test. If you cannot answer them all, reread Subsections 5.2 and 5.3.

5.4 – USING AIR BRAKES

5.4.1 – Normal Stops

Push the brake pedal down. Control the pressure so the vehicle comes to a smooth, safe stop. If you have a manual transmission, do not push the clutch in until the engine rpm is down close to idle. When stopped, select a starting gear.

5.4.2 – Braking With Anti-lock Brakes

- When you brake hard on slippery surfaces in a vehicle without ABS, your wheels may lock up. When your steering wheels lock up, you lose steering control. When your other wheels lock up, you may skid, jackknife, or even spin the vehicle.
- ABS helps you avoid wheel lock up. The computer senses impending lockup, reduces the braking pressure to a safe level, and helps you maintain control.
- You may or may not be able to stop faster with ABS, but you should be able to steer around an obstacle while braking, and avoid skids caused by over braking.
- Having ABS on only the tractor, only the trailer, or even on only 1 axle, still gives you more control over the vehicle during braking. Brake normally.
- When only the tractor has ABS, you should be able to maintain steering control, and there is less chance of jackknifing. But keep your eye on the trailer and let up on the brakes (if you can safely do so) if it begins to swing out.
- When only the trailer has ABS, the trailer is less likely to swing out. But if you lose steering control or start a tractor jackknife, let up on the brakes (if you can safely do so) until you gain control.

- When you drive a tractor-trailer combination with ABS, you should brake as you always have. In other words:
 - Use only the braking force necessary to stop safely and stay in control.
 - Brake the same way, regardless of whether you have ABS on the tractor, trailer, or both.
 - As you slow down, monitor your tractor and trailer and back off the brakes (if it is safe to do so) to stay in control.
 - There is only 1 exception to this procedure. If you always drive a straight truck or combination with working ABS on all axles, in an emergency stop, you can fully apply the brakes.
 - Without ABS, you still have normal brake functions. Drive and brake as you always have.
 - Remember, if your ABS malfunctions, you still have regular brakes. Drive normally, but get the system serviced soon.

5.4.3 – Emergency Stops

If somebody suddenly pulls out in front of you, your natural response is to hit the brakes. This is a good response if there is enough distance to stop, and you use the brakes correctly.

You should brake in a way that will keep your vehicle in a straight line and allow you to turn if it becomes necessary. You can use the “controlled braking” or “stab braking” method.

Controlled Braking. With this method, you apply the brakes as hard as you can without locking the wheels. Keep steering wheel movements very small while doing this. If you need to make a larger steering adjustment or if the wheels lock, release the brakes. Reapply the brakes as soon as you can.

Stab Braking. Apply your brakes all the way. Release the brakes when wheels lock up. As soon as the wheels start rolling, apply the brakes fully again. (It can take up to 1 second for the wheels to start rolling after you release the brakes. If you reapply the brakes before the wheels start rolling, the vehicle will not straighten out.)

5.4.4 – Stopping Distance

Stopping distance was described in Section 2 under “Speed and Stopping Distance.” With air brakes, there is an added delay, “brake lag.” This is the time required for the brakes to work after the brake pedal is pushed. With hydraulic brakes (used on cars and light/medium trucks), the brakes work instantly. However, with air brakes, it takes a little time (1/2 second or more) for the air to flow through the lines to the brakes. Thus, the total stopping distance for vehicles with air brake systems is made up of 4 different factors.

$$\text{Perception Distance} + \text{Reaction Distance} + \text{Brake Lag Distance} + \text{Braking Distance} = \text{Total Stopping Distance}$$

The air brake lag distance at 55 mph on dry pavement adds about 32 feet. Therefore, at 55 mph for an average driver under good traction and brake conditions, the total stopping distance is over 450 feet. See Figure 5.6.

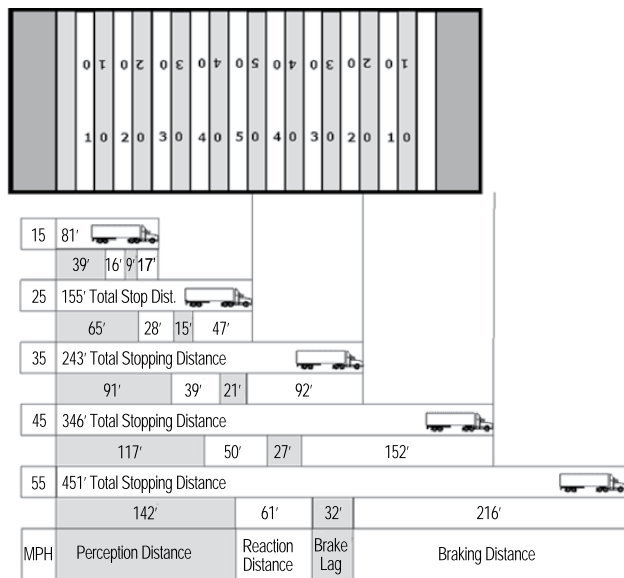

Figure 5.6

5.4.5 – Brake Fading or Failure

Brakes are designed so that brake shoes or pads rub against the brake drum or discs to slow the vehicle. Braking creates heat, but brakes are designed to take a lot of heat. However, brakes can fade or fail from excessive heat caused by using them too much and not relying on the engine braking effect.

Excessive use of the service brakes results in overheating and leads to brake fade. Brake fade results from excessive heat causing chemical changes in the brake lining, which reduce friction, and cause expansion of the brake drums. As the overheated drums expand, the brake shoes and linings have to move farther to contact the drums, and the force of this contact is reduced. Continued overuse may increase brake fade until the vehicle cannot be slowed down or stopped.

Brake fade is also affected by adjustment. To safely control a vehicle, every brake must do its share of the work. Brakes out of adjustment will stop doing their share before those that are in adjustment. The other brakes can then overheat and fade, and there will not be enough braking available to control the vehicle(s). Brakes can get out of adjustment quickly, especially when they are hot. Therefore, check brake adjustment often.

5.4.6 – Proper Braking Technique

Remember, the use of brakes on a long and/or steep downgrade is only a supplement to the braking effect of the engine. Once the vehicle is in the correct low gear, the following is the proper braking technique:

- Apply the brakes just hard enough to feel a definite slowdown.
- When your speed has been reduced to approximately 5 mph below your “safe” speed, release the brakes. (This application should last for about 3 seconds.)

When your speed has increased to your “safe” speed, repeat steps 1 and 2.

If your “safe” speed is 40 mph, you would not apply the brakes until your speed reaches 40 mph. You now apply the brakes hard enough to gradually reduce your speed to 35 mph and then release the brakes. Repeat this as often as necessary until you have reached the end of the downgrade.

5.4.7 – Low Air Pressure

If the low air pressure warning comes on, stop and safely park your vehicle as soon as possible. There might be an air leak in the system. Controlled braking is possible only while enough air remains in the air tanks. The spring brakes will come on when the air pressure drops into the range of 20 to 45 psi. A heavily loaded vehicle will take a long distance to stop because the spring brakes do not work on all axles. Lightly loaded vehicles or vehicles on slippery roads may skid out of control when the spring brakes come on. It is much safer to stop while there is enough air in the tanks to use the foot brakes.

5.4.8 – Parking Brakes

Any time you park, use the parking brakes, except as noted below. Pull the parking brake control knob out to apply the parking brakes and push it in to release. The control will be a yellow, diamond-shaped knob labeled “parking brakes” on newer vehicles. On older vehicles, it may be a round blue knob or some other shape (including a lever that swings from side to side or up and down).

- Do not use the parking brakes if the brakes are very hot (from just having come down a steep grade), or if the brakes are very wet in freezing temperatures. If they are used while they are very hot, they can be damaged by the heat. If they are used in freezing temperatures when the brakes are very wet, they can freeze so the vehicle cannot move. Use wheel chocks on a level surface to hold the vehicle. Let hot brakes cool before using the parking brakes. If the brakes are wet, use the brakes lightly while driving in a low gear to heat and dry them.
- If your vehicle does not have automatic air tank drains, drain your air tanks at the end of each working day to remove moisture and oil. Otherwise, the brakes could fail.

Never leave your vehicle unattended without applying the parking brakes or chocking the wheels. Your vehicle might roll away and cause injury and damage.

SUBSECTION 5.4

Test Your Knowledge

15. Why should you be in the proper gear before starting down a hill?
16. What factors can cause brakes to fade or fail?
17. The use of brakes on a long, steep downgrade is only a supplement to the braking effect of the engine. True or False?
18. If you are away from your vehicle only a short time, you do not need to use the parking brake. True or False?
19. How often should you drain air tanks?
20. How do you brake when you drive a tractor-trailer combination with ABS?
21. You still have normal brake functions if your ABS is not working. True or False?

These questions may be on your test. If you cannot answer them all, reread Subsection 5.4.



Get Onboard with REAL ID at REALID.dmv.ca.gov



Start your application online



Upload required documents

(one proof of identity and two proofs of residency)



Make a DMV appointment

Bring confirmation code and original documents
(DMV does not keep original documents)

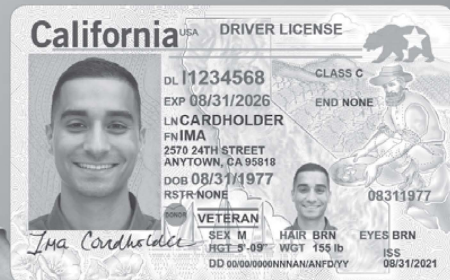

REAL ID

SECTION 6: COMBINATION VEHICLES

THIS SECTION COVERS

- 6.1 – Driving Combination Vehicles Safely
- 6.2 – Combination Vehicle Air Brakes
- 6.3 – Anti-lock Brake Systems
- 6.4 – Coupling and Uncoupling
- 6.5 – Inspecting a Combination Vehicle

This section provides information needed to pass the tests for combination vehicles (tractor-trailer, doubles, triples, straight truck with trailer). The information is only to give you the minimum knowledge needed for driving common combination vehicles. You should also study Section 7 if you need to pass the test for doubles and triples.

6.1 – DRIVING COMBINATION VEHICLES SAFELY

Combination vehicles are usually heavier, longer, and require more driving skill than single CMVs. This means that drivers of combination vehicles need more knowledge and skill than drivers of single vehicles. This section has important safety factors that apply specifically to combination vehicles.

6.1.1 – Rollover Risks

More than half of truck driver deaths in accidents are the result of truck rollovers. When more cargo is piled up in a truck, the “center of gravity” moves higher up from the road and the truck becomes easier to turn over. Fully loaded rigs are 10 times more likely to roll over in an accident than empty rigs.

The following 2 things will help you prevent rollover: keep the cargo as close to the ground as possible, and drive slowly around turns. Keeping cargo low is even more important in combination vehicles than in

straight trucks. Also, keep the load centered on your rig. If the load is to one side so it makes a trailer lean, a rollover is more likely. Make sure your cargo is centered and spread out as much as possible. (Cargo distribution is covered in Section 3 of this handbook.)

Rollovers happen when you turn too fast. Drive slowly around corners, on ramps, and off ramps. Avoid quick lane changes, especially when fully loaded.

6.1.2 – Steer Gently

Trucks with trailers have a dangerous “crack-the-whip” effect. When you make a quick lane change, the crack-the-whip effect can turn the trailer over. There are many accidents where only the trailer has overturned.

“Rearward amplification” causes the crack-the-whip effect. Figure 6.1 shows 8 types of combination vehicles and the rearward amplification each has in a quick lane change. Rigs with the least crack-the-whip effect are shown at the top, and those with the most at the bottom. Rearward amplification of 2.0 in the chart means that the rear trailer is twice as likely to turn over as the tractor. You can see that triples have a rearward amplification of 3.5. This means you can roll the last trailer of triples 3.5 times as easily as a 5-axle tractor.

Steer gently and smoothly when you are pulling trailers. If you make a sudden movement with your steering wheel, your trailer could tip over. Follow far enough behind other vehicles (at least 1 second for each 10 feet of your vehicle length, plus another second if going over 40 mph). Look far enough down the road to avoid being surprised and having to make a sudden lane change. At night, drive slowly enough to see obstacles with your headlights before it is too late to change lanes or stop gently. Slow down to a safe speed before going into a turn.

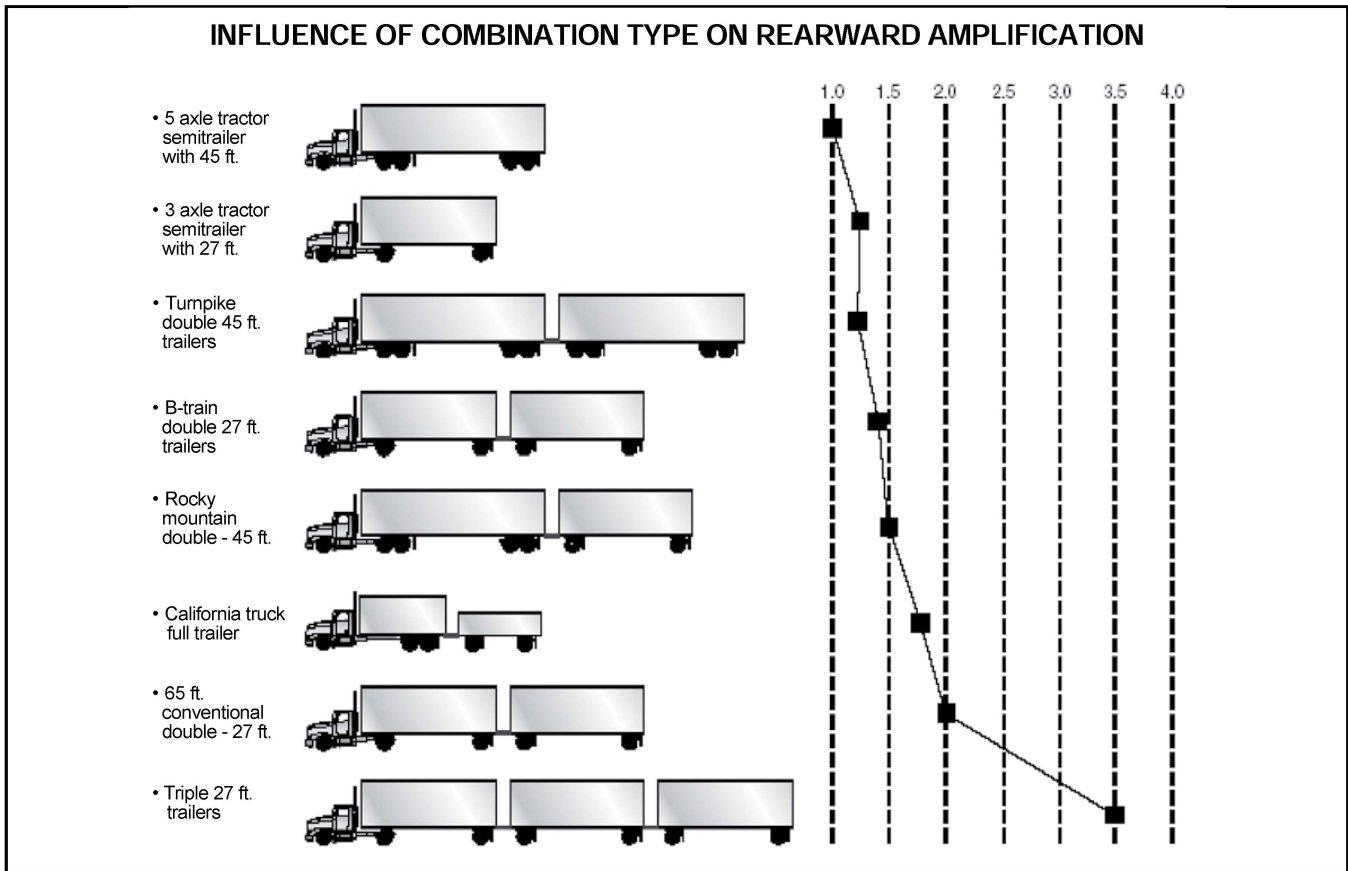

Figure 6.1

6.1.3 – Brake Early

Control your speed whether fully loaded or empty. Large combination vehicles take longer to stop when they are empty than when they are fully loaded. When lightly loaded, the very stiff suspension springs and strong brakes give poor traction and make it very easy to lock up the wheels. Your trailer can swing out and strike other vehicles. Your tractor can jackknife very quickly. You also must be very careful about driving “bobtail” tractors (tractors without semitrailers). Bobtails can be very hard to stop smoothly. It takes them longer to stop than a tractor-semitrailer loaded to maximum gross weight.

In any combination rig, allow lots of following distance and look far ahead so you can brake early. Do not be caught by surprise and have to make a “panic” stop.

6.1.4 – Railroad-Highway Crossings

Railroad-highway crossings can also cause problems, particularly when pulling trailers with low underneath clearance.

These trailers can get stuck on raised crossings:

- Low slung units (lowboy, car carrier, moving van, or possum-belly livestock trailer).
- Single-axle tractor pulling a long trailer with its landing gear set to accommodate a tandem-axle tractor.

If for any reason you get stuck on the tracks, get out of the vehicle and away from the tracks. Check signposts or signal housing at the crossing for emergency notification information. Call 9-1-1 or another emergency number. Give the location of the crossing using all identifiable landmarks, especially the DOT number, if posted.

6.1.5 – Prevent Trailer Skids

When the wheels of a trailer lock up, the trailer will tend to swing around. This is more likely to happen when the trailer is empty or lightly loaded. This type of jackknife is often called a “trailer jackknife.” See Figure 6.2.

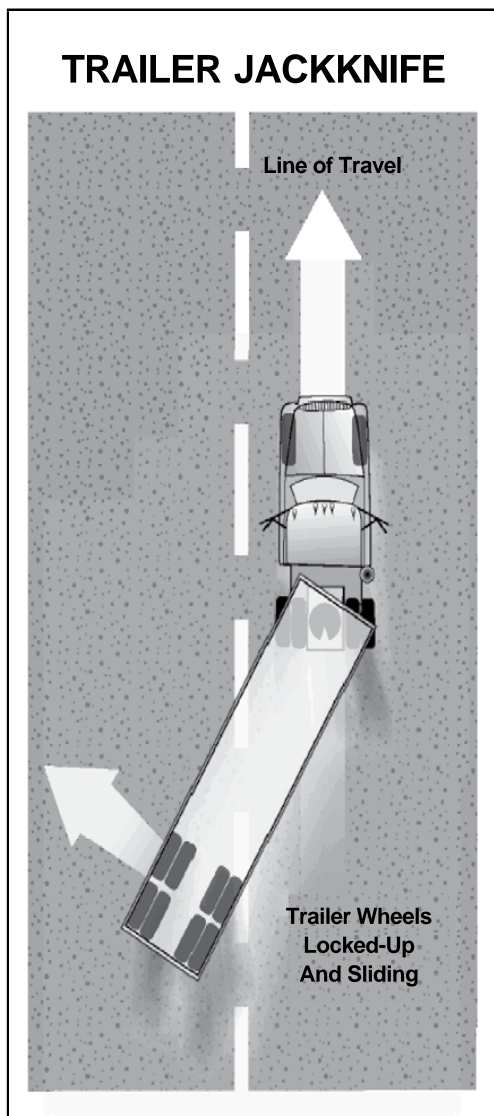

Figure 6.2

The procedure for stopping a trailer skid is:

- **Recognize the Skid.** The earliest and best way to recognize that the trailer has started to skid is by seeing it in your mirrors. Any time you apply the brakes hard, check the mirrors to make sure the trailer is staying where it should be. Once the trailer swings out of your lane, it is very difficult to prevent a jackknife.

- **Stop Using the Brake.** Release the brakes to get traction back. Do not use the trailer hand brake (if you have one) to “straighten out the rig.” This is the wrong thing to do since the brakes on the trailer wheels caused the skid in the first place. Once the trailer wheels grip the road again, the trailer will start to follow the tractor and straighten out.

6.1.6 – Turn Wide

When a vehicle goes around a corner, the rear wheels follow a different path than the front wheels. This is called off-tracking or “cheating.” Figure 6.3 shows how off-tracking causes the path followed by a tractor to be wider than the rig itself. Longer vehicles will off-track more. The rear wheels of the powered unit (truck or tractor) will off-track some, and the rear wheels of the trailer will off-track even more. If

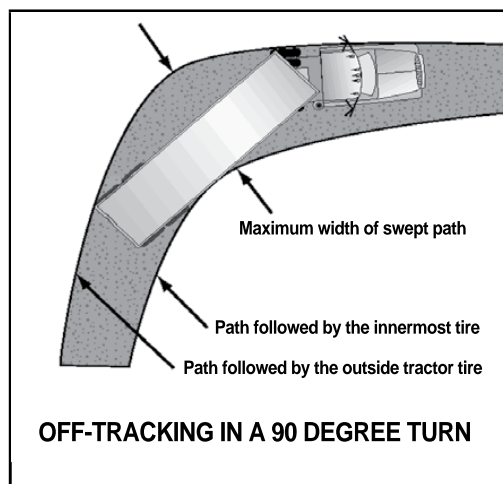

Figure 6.3

there is more than one trailer, the rear wheels of the last trailer will off-track the most. Steer the front end wide enough around a corner so the rear end does not run over the curb, pedestrians, etc. However, keep the rear of your vehicle close to the curb. This will stop other drivers from passing you on the right. If you cannot complete your turn without entering another traffic lane, turn wide as you complete the turn. This is better than swinging wide to the left before starting the turn because it will keep other drivers from passing you on the right. See Figure 6.4.

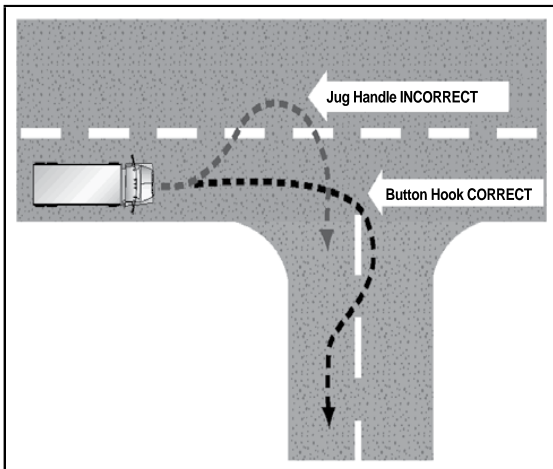

Figure 6.4

6.1.7 – Backing With a Trailer

When backing a car, straight truck, or bus, turn the top of the steering wheel in the direction you want to go. When backing a trailer, turn the steering wheel in the opposite direction. Once the trailer starts to turn, turn the wheel the other way to follow the trailer.

Whenever you back up with a trailer, try to position your vehicle so you can back in a straight line. If you must back on a curved path, back toward the driver's side so you can see. See Figure 6.5.

Look at Your Path. Look at your line of travel before you begin. Get out and walk around the vehicle. Check your clearance to the sides and overhead, in and near the path of your vehicle.

Use Mirrors on Both Sides. Check the outside mirrors on both sides frequently. Get out of the vehicle and re-inspect your path if you are unsure.

Back Slowly. This will let you make corrections before you get too far off course.

Correct Drift Immediately. As soon as you see the trailer getting off the proper path, correct it by turning the top of the steering wheel in the direction of the drift.

Pull Forward. When backing a trailer, make pull-ups to reposition your vehicle as needed.

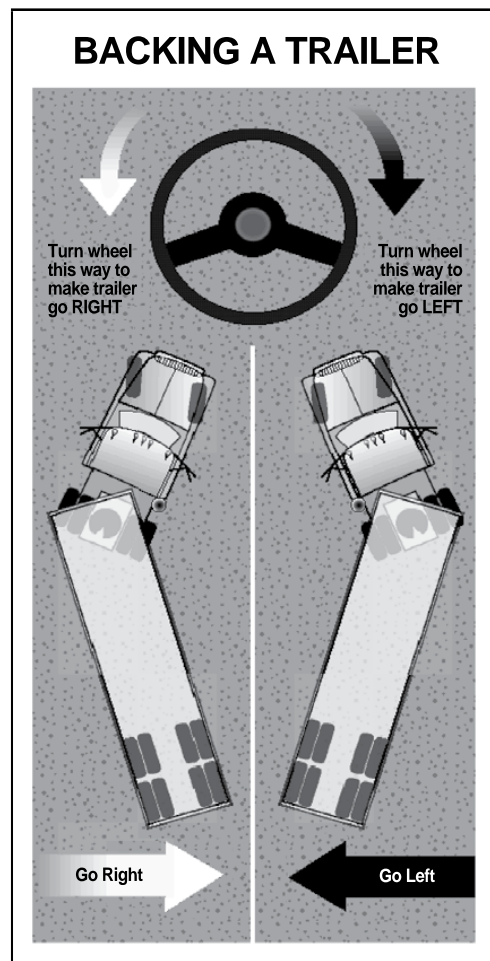

Figure 6.5

SUBSECTION 6.1

Test Your Knowledge

1. What 2 things are important to prevent a rollover?
2. When you turn suddenly while pulling doubles, which trailer is most likely to turn over?
3. Why should you not use the trailer hand brake to straighten out a jackknifing trailer?
4. What is off-tracking?
5. When you back a trailer, you should position your vehicle so you can back in a curved path to the driver's side. True or False?
6. What type of trailers can get stuck on railroad-highway crossings?

These questions may be on your test. If you cannot answer them all, reread Subsection 6.1.

6.2 – COMBINATION VEHICLE AIR BRAKES

You should study Section 5: Air Brakes before reading this. In combination vehicles, the braking system has parts to control the trailer brakes, in addition to the parts described in Section 5. These parts are described below.

6.2.1 – Trailer Hand Valve

The trailer hand valve (also called the trolley valve or Johnson bar) works the trailer brakes. The trailer hand valve should be used only to test the trailer brakes. Do not use it in driving because of the danger of making the trailer skid. The foot brake sends air to all of the brakes on the vehicle, including the trailer(s). There is much less danger of causing a skid or jackknife when using just the foot brake.

Never use the hand valve for parking because all the air might leak out, unlocking the brakes (in trailers that do not have spring brakes). Always use the parking brakes when parking. If the trailer does not have spring brakes, use wheel chocks to keep the trailer from moving.

6.2.2 – Tractor Protection Valve

The tractor protection valve keeps air in the tractor or truck brake system should the trailer break away or develop a bad leak. The tractor protection valve is controlled by the “trailer air supply” control valve in the cab. The control valve allows you to open and shut the tractor protection valve. The tractor protection valve will close automatically if air pressure is low (in the range of 20 to 45 psi). When the tractor protection valve closes, it stops any air from going out of the tractor. It also lets the air out of the trailer emergency line. This causes the trailer emergency brakes to come on, with possible loss of control. (Emergency brakes are covered later.)

6.2.3 – Trailer Air Supply Control

The trailer air supply control on newer vehicles is a red 8-sided knob, which you use to control the tractor protection valve. You push it in to supply the trailer with air, and pull it out to shut the air off and put on the trailer emergency brakes. The valve will pop out (which closes the tractor protection valve) when the air pressure drops into the range of 20 to 45 psi. Tractor protection valve controls or “emergency” valves on older vehicles may not operate automatically. There may be a lever rather than a knob. The “normal” position is used for pulling a trailer. The “emergency” position is used to shut the air off and put on the trailer emergency brakes.

6.2.4 – Trailer Air Lines

Every combination vehicle has 2 air lines, the service line and emergency line. They run between each vehicle (tractor to trailer, trailer to dolly, dolly to second trailer, etc.).

Service Air Line. The service line (also called the control line or signal line) carries air, which is controlled by the foot brake or trailer hand brake. Depending on how hard you press the foot brake or hand valve, the pressure in the service line will similarly change. The service line is connected to relay valves. These valves allow the trailer brakes to be applied more quickly than would otherwise be possible.

Emergency Air Line. The emergency line (also called the supply line) has 2 purposes. First, it supplies air to the trailer air tanks. Second, the emergency line controls the emergency brakes on combination vehicles. Loss of air pressure in the emergency line causes the trailer emergency brakes to come on. The pressure loss could be caused by a trailer breaking loose and thus tearing apart the emergency air hose. Or it could be caused by a hose, metal tubing, or other part breaking and letting the air out. When the emergency line loses pressure, it also causes the tractor protection valve to close (the air supply knob will pop out).

Emergency lines are often coded with the color red (red hose, red couplers, or other red parts) to keep from getting them mixed up with the blue service line.

6.2.5 – Hose Couplers (Glad Hands)

Glad hands are coupling devices used to connect the service and emergency air lines from the truck or tractor to the trailer. The couplers have a rubber seal, which prevents air from escaping. Clean the couplers and rubber seals before a connection is made. When connecting the glad hands, press the two seals together with the couplers at a 90-degree angle to each other. A turn of the glad hand attached to the hose will join and lock the couplers.

When coupling, make sure to couple the proper glad hands together. Colors are sometimes used to help avoid mistakes. Blue is used for the service lines and red for the emergency (supply) lines. Sometimes, metal tags are attached to the lines with the words “service” and “emergency” stamped on them. See Figure 6.6.

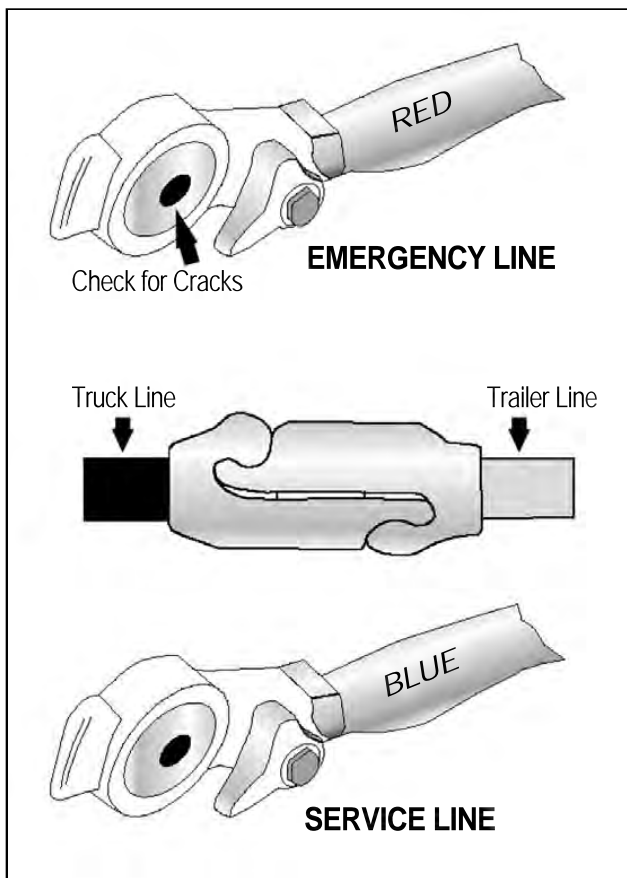

Figure 6.6

If you cross the air lines, supply air will be sent to the service line instead of going to charge the trailer air tanks. Air will not be available to release the trailer spring brakes (parking brakes). If the spring brakes do not release when you push the trailer air supply control, check the air line connections.

Older trailers do not have spring brakes. If the air supply in the trailer air tank has leaked away, there will be no emergency brakes and the trailer wheels will turn freely. If you cross the air lines, you can drive away but you will not have trailer brakes. This would be very dangerous. Always test the trailer brakes before driving with the hand valve or by pulling the air supply (tractor protection valve) control. Pull gently against them in a low gear to make sure the brakes work.

Some vehicles have “dead end” or dummy couplers that hoses may be attached to when not in use. This will prevent water and dirt from getting into the coupler and air lines. Use the dummy couplers when the air lines are not connected to a trailer. If there are no dummy couplers, the glad hands can sometimes be locked together (depending on the couplings). It is very important to keep the air supply clean.

6.2.6 – Trailer Air Tanks

Each trailer and converter dolly has one or more air tanks. They are filled by the emergency (supply) line from the tractor. They provide the air pressure used to operate trailer brakes. Air pressure is sent from the air tanks to the brakes by relay valves.

The pressure in the service line tells how much pressure the relay valves should send to the trailer brakes. The pressure in the service line is controlled by the brake pedal (and trailer hand brake).

It is important that you do not let water and oil build up in the air tanks. If you do, the brakes may not work correctly. Each tank has a drain valve on it and you should drain each tank every day. If your tanks have automatic drains, they will keep most moisture out. You should still open the drains to make sure.

6.2.7 – Shut-Off Valves

Shut-off valves are used in the service and supply air lines at the back of trailers used to tow other trailers. These valves permit closing the air lines off when another trailer is not being towed. You must check that all shut-off valves are in the open position except the ones at the back of the last trailer, which must be closed.

6.2.8 – Trailer Service, Parking, and Emergency Brakes

Newer trailers have spring brakes just like trucks and truck tractors. However, converter dollies and trailers built before 1975 are not required to have spring brakes. Those that do not have spring brakes have emergency brakes, which work from the air stored in the trailer air tank. The emergency brakes come on whenever air pressure in the emergency line is lost. These trailers have no parking brake. The emergency brakes come on whenever the air supply knob is pulled out or the trailer is disconnected. A major leak in the emergency line will cause the tractor protection valve to close and trailer emergency brakes to come on. However, the brakes will hold only as long as there is air pressure in the trailer air tank. Eventually, the air will leak away and there will be no brakes. Therefore, it is very important for safety that you use wheel chocks when you park trailers without spring brakes.

You may not notice a major leak in the service line until you try to put the brakes on. Then, the air loss from the leak will lower the air tank pressure quickly. If it goes low enough, the trailer emergency brakes will come on.

SUBSECTION 6.2

Test Your Knowledge

7. Why should you not use the trailer hand valve while driving?
8. Describe what the trailer air supply control does.
9. Describe what the service line is for.
10. What is the emergency air line for?
11. Why should you use chocks when parking a trailer without spring brakes?
12. Where are shut-off valves?

These questions may be on your test. If you cannot answer them all, reread Subsection 6.2.

6.3 – ANTI-LOCK BRAKE SYSTEMS

6.3.1 – Trailers Required to Have ABS

- All trailers and converter dollies built on or after March 1, 1998, are required to have ABS. However, many trailers and converter dollies built before this date have been voluntarily equipped with ABS.
- Trailers will have yellow ABS malfunction lamps on the left side, either on the front or rear corner. See Figure 6.7. Dollies manufactured on or after March 1, 1998, are required to have a lamp on the left side.
- In the case of vehicles manufactured before the required date, it may be difficult to tell if the unit is equipped with ABS. Look under the vehicle for the ECU and wheel speed sensor wires coming from the back of the brakes.

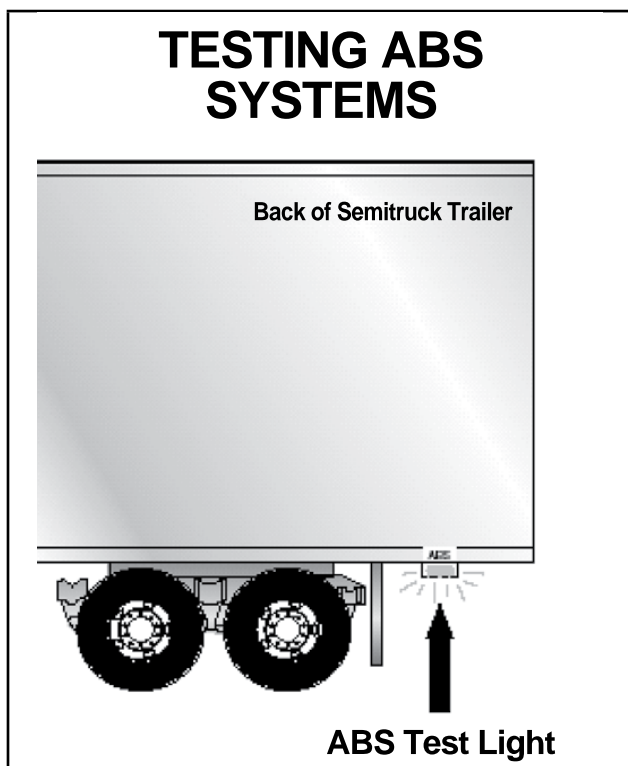

Figure 6.7

6.3.2 – Braking With ABS

- ABS is an addition to your normal brakes. It does not decrease or increase your normal braking capability. ABS only activates when wheels are about to lock up.
- ABS does not necessarily shorten your stopping distance, but it helps you keep the vehicle under control during hard braking.
- ABS helps you avoid wheel lock up. The computer senses impending lockup, reduces the braking pressure to a safe level, and you maintain control.
- ABS on only the trailer, or even on only 1 axle, still gives you more control over the vehicle during braking.
- When only the trailer has ABS, the trailer is less likely to swing out, but if you lose steering control or start a tractor jackknife, let up on the brakes (if you can safely do so) until you gain control.
- When you drive a tractor-trailer combination with ABS, you should brake as you always have. In other words:
 - Use only the braking force necessary to stop safely and stay in control.
 - Brake the same way, regardless of whether you have ABS on the tractor, trailer, or both.
 - As you slow down, monitor your tractor and trailer and back off the brakes (if it is safe to do so) to stay in control.

Remember, if your ABS malfunctions, you still have regular brakes. Drive normally, but get the system serviced soon.

ABS will not allow you to drive faster, follow more closely, or drive less carefully.

6.4 – COUPLING AND UNCOUPLING

Knowing how to couple and uncouple correctly is basic to safe operation of combination vehicles. Wrong coupling and uncoupling can be very dangerous. General coupling and uncoupling steps are listed below. There are differences between different rigs, so learn the details of coupling and uncoupling the truck(s) you will operate.

6.4.1 – Coupling Tractor-Semitrailers

Step 1: Inspecting the Fifth-Wheel

- Check for damaged and missing parts.
- Check to see that the mounting to the tractor is secure, no cracks in the frame, etc.
- Be sure that the fifth-wheel plate is greased as required. Failure to keep the fifth-wheel plate lubricated could cause steering problems because of friction between the tractor and trailer.
- Check if the fifth-wheel is in proper position for coupling:
 - Wheel is tilted down towards the rear of the tractor.
 - Jaws are open.
 - Safety unlocking handle is in the automatic lock position.
 - If you have a sliding fifth-wheel, make sure it is locked.
 - Make sure the trailer kingpin is not bent or broken.

Step 2: Inspect the Area and Chock the Wheels

- Make sure the area around the vehicle is clear.
- Be sure the trailer wheels are chocked or spring brakes are on.
- Check that the cargo (if any) is secured against movement due to the tractor being coupled to the trailer.

Step 3: Position the Tractor

- Put the tractor directly in front of the trailer. (Never back under the trailer at an angle because you might push the trailer sideways and break the landing gear.)
- Check your position, using the outside mirrors, by looking down both sides of the trailer.

Step 4: Back Slowly

- Back until the fifth-wheel just touches the trailer.
- Do not hit the trailer.

Step 5: Secure the Tractor

- Apply the parking brakes.
- Put the transmission in Neutral.

Step 6: Check the Trailer Height

- The trailer should be low enough that it is raised slightly by the tractor when the tractor is backed under it. Raise or lower the trailer as needed. (If the trailer is too low, the tractor may strike and damage the trailer nose; if the trailer is too high, it may not couple correctly.)
- Check that the kingpin and the fifth-wheel are aligned.

Step 7: Connect Air Lines to the Trailer

- Check the glad hand seals and connect the tractor emergency air line to the trailer emergency glad hand.
- Check the glad hand seals and connect the tractor service air line to the trailer service glad hand.
- Make sure the air lines are safely supported where they will not be crushed or caught while the tractor is backing under the trailer.

Step 8: Supply Air to the Trailer

- From the cab, push in the “air supply” knob or move the tractor protection valve control from the “emergency” to the “normal” position to supply air to the trailer brake system.
- Wait until the air pressure is normal.
- Check the brake system for crossed air lines.
 - Shut the engine off so you can hear the brakes.
 - Apply and release the trailer brakes and listen for the sound of trailer brakes being applied and released. You should hear the brakes move when applied and air escape when the brakes are released.
 - Check the air brake system pressure gauge for signs of major air loss.
- When you are sure the trailer brakes are working, start the engine.
- Make sure the air pressure is up to normal.

Step 9: Lock the Trailer Brakes

Pull out the “air supply” knob or move the tractor protection valve control from “normal” to “emergency.”

Step 10: Back Under the Trailer

- Use the lowest reverse gear.
- Back the tractor slowly under the trailer to avoid hitting the kingpin too hard.
- Stop when the kingpin is locked into the fifth-wheel.

Step 11: Check the Connection for Security

- Raise the trailer landing gear slightly off the ground.
- Pull the tractor gently forward while the trailer brakes are still locked to check that the trailer is locked onto the tractor.

Step 12: Secure the Vehicle

- Put the transmission in Neutral.
- Apply the parking brakes.
- Shut off the engine and take the key with you so someone else will not move the truck while you are under it.

Step 13: Inspect the Coupling

- Use a flashlight, if necessary.
- Make sure there is no space between the upper and the lower fifth-wheel. If there is space, something is wrong (the kingpin may be on top of the closed fifth-wheel jaws, and the trailer would come loose very easily).
- Go under the trailer and look into the back of the fifth-wheel. Make sure the fifth-wheel jaws have closed around the shank of the kingpin.
- Check that the locking lever is in the “lock” position.
- Check that the safety latch is in position over the locking lever. (On some fifth-wheels the catch must be put in place by hand.)
- If the coupling is not right, do not drive the coupled unit; get it fixed.

Step 14: Connect the Electrical Cord and Check the Air Lines

- Plug the electrical cord into the trailer and fasten the safety catch.
- Check both the air and electrical lines for signs of damage.
- Make sure the air and electrical lines will not hit any moving parts of the vehicle.

Step 15: Raise the Front Trailer Supports (Landing Gear)

- Use the low gear range (if so equipped) to begin raising the landing gear. Once free of weight, switch to the high gear range.
- Raise the landing gear all the way up. (Never drive with landing gear only part way up, it may catch on railroad tracks or other things.)
- After raising the landing gear, secure the crank handle safely.
- When the full weight of the trailer is resting on the tractor:
 - Check for enough clearance between the rear of the tractor frame and landing gear. (When the tractor turns sharply, it must not hit the landing gear.)
 - Check that there is enough clearance between the top of the tractor tires and nose of the trailer.

Step 16: Remove the Trailer Wheel Chocks

Remove and store the wheel chocks in a safe place.

6.4.2 – Uncoupling the Tractor-Semitrailers

The following steps will help you to uncouple safely.

Step 1: Position the Rig

- Make sure the surface of the parking area can support the weight of the trailer.
- Have the tractor lined up with the trailer. (Pulling out at an angle can damage the landing gear.)

Step 2: Ease the Pressure on the Locking Jaws

- Shut off the trailer air supply to lock the trailer brakes.
- Ease the pressure on the fifth-wheel locking jaws by backing up gently. (This will help you release the fifth-wheel locking lever.)
- Put the parking brakes on while the tractor is pushing against the kingpin. (This will hold the rig with pressure off the locking jaws.)

Step 3: Chock the Trailer Wheels

Chock the trailer wheels if the trailer does not have spring brakes or you are not sure. (The air could leak out of the trailer air tank, releasing its emergency brakes. Without the chocks, the trailer could move.)

Step 4: Lower the Landing Gear

- If the trailer is empty, lower the landing gear until it makes firm contact with the ground.
- If the trailer is loaded, after the landing gear makes firm contact with the ground, turn the crank in low gear a few extra turns. This will lift some weight off the tractor. (Do not lift the trailer off the fifth-wheel.) This will make it easier to:
 - Unlatch the fifth-wheel.
 - Couple next time.

Step 5: Disconnect Air Lines and Electrical Cable

- Disconnect the air lines from the trailer. Connect the air line glad hands to the dummy couplers at the back of the cab or couple them together.
- Hang the electrical cable with the plug down to prevent moisture from entering it.
- Make sure the lines are supported so they will not be damaged while driving the tractor.

Step 6: Unlock the Fifth-Wheel

- Raise the release handle lock.
- Pull the release handle to the “open” position.
- Keep legs and feet clear of the rear tractor wheels to avoid serious injury in case the vehicle moves.

Step 7: Pull the Tractor Partially Clear of the Trailer

- Pull the tractor forward until the fifth-wheel comes out from under the trailer.
- Stop with the tractor frame under the trailer (prevents the trailer from falling to the ground if the landing gear should collapse or sink).

Step 8: Secure the Tractor

- Apply the parking brake.
- Place the transmission in Neutral.

Step 9: Inspect the Trailer Supports

- Make sure the ground is supporting the trailer.
- Make sure the landing gear is not damaged.

Step 10: Pull the Tractor Clear of the Trailer

- Release the parking brakes.
- Check the area and drive the tractor forward until it clears.

6.4.3 – Coupling a Pintle Hook

Step 1: Inspect the Pintle Hook

Before operating, check for worn, damaged, or missing parts, and make sure the mount is secure. If the pintle hook is not secured to the mounting surface, the pintle hook could separate from the vehicle, which, if not avoided, could result in death or serious injury.

Step 2: Unlock the Lock Pin and Open Latch

Unlock and remove the tethered lock pin, if applicable.

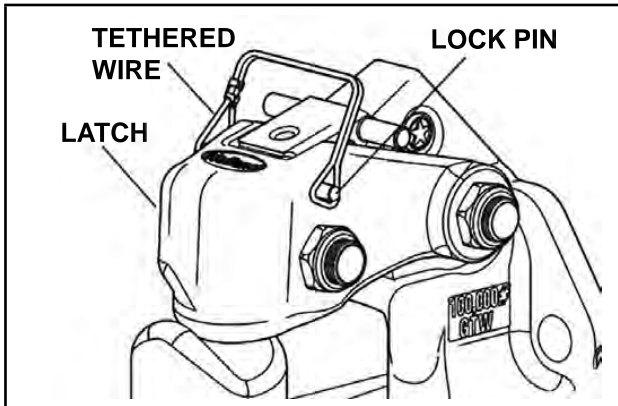

Figure 6.8

Lift the lock handle away from the vehicle until the lock clears the lock seat on the hook body. Open the latch by rotating the latch assembly up toward the vehicle until the latch is in its most upright position, and then release the lock handle. (See Figure 6.9 and 6.10.)

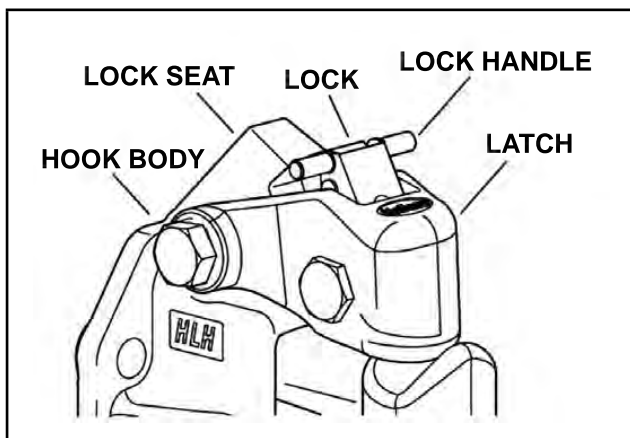

Figure 6.9

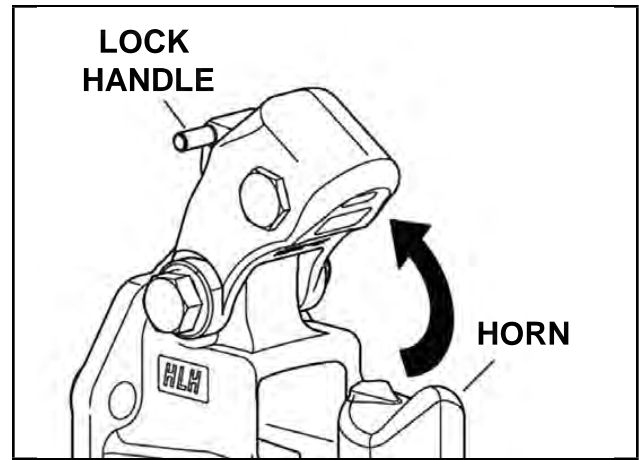

Figure 6.10

Step 3: Lower the Drawbar Into Place

Position the drawbar eye over the horn of the pintle hook and lower it into place.

Step 4: Lock the Pintle Hook

Push the latch closed. When correctly locked, the lock handle will rotate and move up until it is flush with the top of the latch. (See Figure 6.11.)

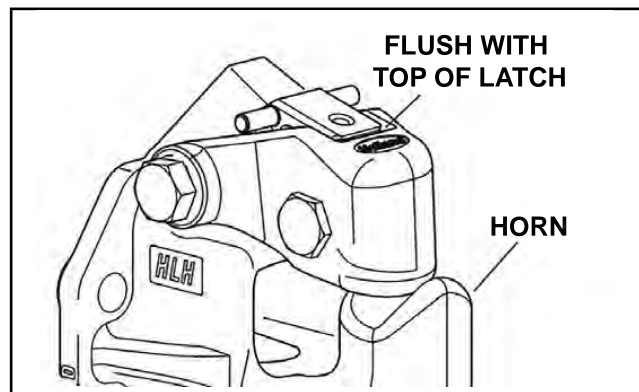

Figure 6.11

Insert the tethered lock pin through the latch and lock holes, and close the tethered wire lock pin, if applicable. See Figure 6.8. Failure to correctly lock the latch can result in separation of the trailer and vehicle, which, if not avoided, could result in death or serious injury.

6.4.4 – Uncoupling a Pintle Hook

Step 1: Park on a Level Surface

Park the trailer on a firm level surface and block trailer tires.

Step 2: Disconnect the Electrical Connector, Breakaway Brake Switch, and Safety Chains

- Disconnect the electrical connector.
- Disconnect the breakaway brake switch lanyard.
- Disconnect the safety chains from the tow vehicle.

Step 3: Unlock the Coupler

Unlock the coupler and open it.

Step 4: Check the Ground Surface for Correct Support

Before extending the jack, make certain the ground surface below the jack pad will support the tongue load.

Step 5: Rotate the Jack Handle

Rotate the jack handle to extend the jack and transfer the weight of the trailer tongue to the jack.

Step 6: Raise the Trailer Coupler

Raise the trailer coupler above the tow vehicle hitch.

Step 7: Drive Forward

Drive the tow vehicle forward.

6.4.5 – Coupling a Drawbar

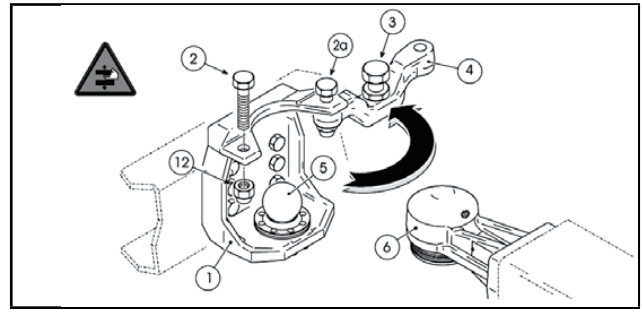

Figure 6.12

Step 1: Remove the Safety Lock Screw and Rotate the Safety Cover Bar

- Remove the safety lock screw (2), recover and keep the relative self-locking nut (12) aside.
- Loosen the safety lock screw (2a) and turn the adjustment screw (3) outwards at least 5 turns.
- Rotate the safety cover bar (4) outwards so that it is completely open.

Step 2: Reverse the Truck

Reverse the truck very slowly until the ball cup drawbar eye (6) is in position exactly above the drawbar-coupling ball (5).

Step 3: Lower the Drawbeam

Lower the drawbeam until the ball cup drawbar eye (6) lies completely covering the drawbar-coupling ball (5).

Step 4: Rotate the Safety Cover Bar

- Rotate the safety cover bar back inwards (4) and fit in safety lock screw (2) together with its self-locking nut.
- Tighten in both the lock screws (2, 2a) together with their relative self-locking nuts (12) at a 350 to 400 newton meters (Nm) torque wrench setting.

Step 5: Adjust the Adjustment Screw

- Adjust the adjustment screw (3) until a 0.3—0.5 mm vertical clearance between the guard disk (13) and the ball cup (6) is reached.
- Lock the setting with counter nut (11).

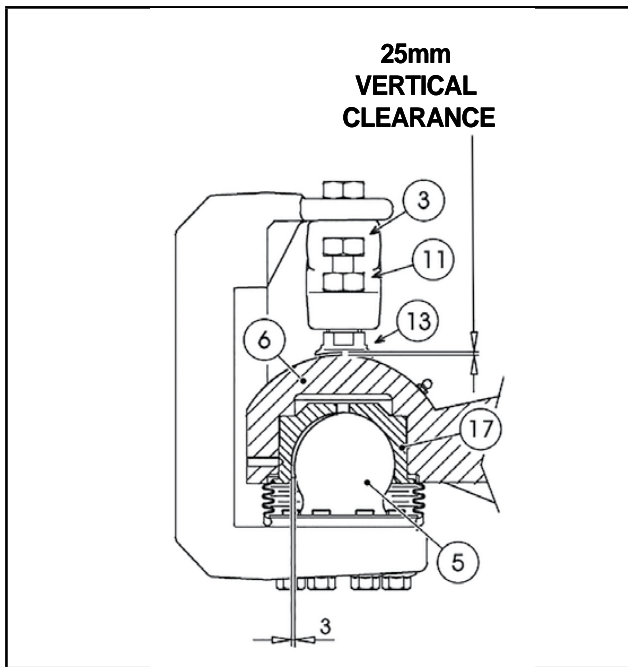

Figure 6.13

In the event that the safety cover bar (4) will not perfectly lodge into its seating appropriately, travel is strictly forbidden.

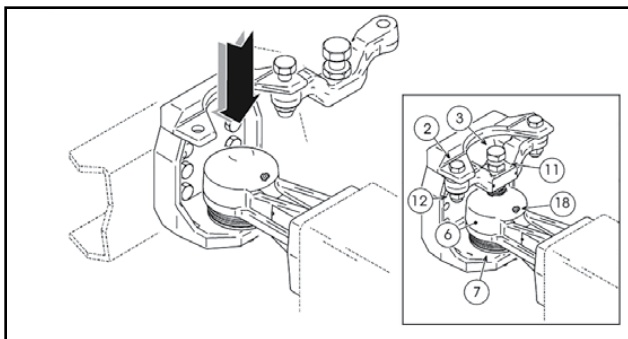

Figure 6.14

Step 6: Protect the Coupling Ball and Anchor the Edge Onto Ball

- Protect the part that is still visible of the coupling ball (5) with the rubber dust proof bellows protection cover (7).
- Accurately anchor the edge directly onto the ball itself.

Step 7: Lubricate the Drawbar Eye

Lubricate the inside of the drawbar eye ball cup (6) directly through the grease nipple (18).

6.4.6 – Uncoupling a Drawbar

Step 1: Turn the Trailer Brake On

Make sure that the trailer brake is on.

Step 2: Remove the Cover and Loosen the Screws

- Remove the rubber dust proof bellows protection cover (7).
- Loosen the adjustment screw (3) and the counter nut (11).
- Loosen safety lock screw (2a) and remove safety lock screw (2) together with its self-locking nut (12).

Step 3: Rotate the Safety Cover Bar and Lift Trailer Drawbeam

- Rotate the safety cover bar (4) outwards so that it is completely open.
- Lift the trailer drawbeam until the drawbar-coupling ball (5) is fully visible, and then travel forward with the trailer very slowly.
- Rotate the safety cover bar inwards (4) until it lodges back in its housing.

Step 4: Lock the Safety Screw and Tighten the Self-Locking Nut

- Fit in the safety lock screw (2) and tighten in the self-locking nut (12).

6.4.7 – Coupling a Gooseneck Hitch

If you are hooking up a gooseneck or a fifth-wheel hitch, the procedure is a little different from a receiver and ball, but it is not difficult.

Step 1: Open the Latch and Lubricate the Gooseneck Ball

- Open the clamp latch on the gooseneck coupler.
- Make sure that the gooseneck ball is properly lubricated.

Step 2: Position the Coupler and Latch the Clamp

- Position the trailer's coupler directly over the ball.
- Lower the gooseneck trailer into position.
- Latch the clamp.

Step 3: Attach the Safety Chains

- Attach your safety chains.
- Remember that all trailers are required by law to have safety chains.

Step 4: Connect the Trailer Light Wiring

- Connect your trailer light wiring to your vehicle's connector.
- Check all of your lights, including your brake lights.

Step 5: Lower and Stow the Trailer Jacks

Completely lower and stow the trailer jacks, allowing the weight to settle onto the tow vehicle.

6.4.8 – Uncoupling a Gooseneck Hitch

Step 1: Remove the Safety Pin and Clip

Simply remove the safety pin and clip.

Step 2: Rotate the Handle and Raise the Trailer Off the Ball

- Rotate the handle to this position (See Figure 6.15) and raise the trailer off the ball.
- The coupler will return to the load position automatically.

Step 3: Install the Safety Pin and Clip

Install the safety pin and clip. (See Figure 6.15.)

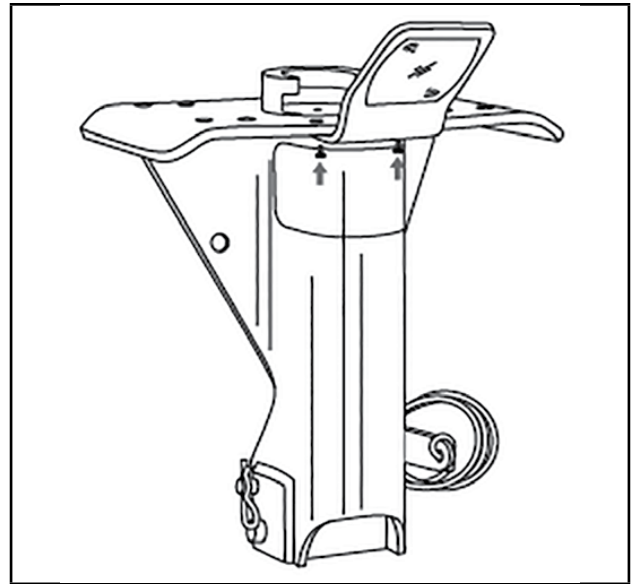

Figure 6.15

SUBSECTIONS 6.3 AND 6.4

Test Your Knowledge

13. What might happen if the trailer is too high when you try to couple?
14. After coupling, how much space should be between the upper and lower fifth-wheel?
15. You should look into the back of the fifth-wheel to see if it is locked onto the kingpin. True or False?
16. To drive, you need to raise the landing gear only until it just lifts off the pavement. True or False?
17. How do you know if your trailer is equipped with anti-lock brakes?

These questions may be on your test. If you cannot answer them all, reread Subsections 6.3 and 6.4.

6.5 – INSPECTING A COMBINATION VEHICLE

Use the 7-step inspection procedure described in Section 2 to inspect your combination vehicle. There are more things to inspect on a combination vehicle than on a single vehicle (for example, tires, wheels, lights, reflectors, etc.). There are also some new things to check. These are discussed below.

6.5.1 – Additional Things to Check During a Walk Around Inspection

Do these checks in addition to those already listed in Section 2.

Coupling System Areas

- Check the fifth-wheel (lower).
 - Is securely mounted to the frame.
 - Has no missing or damaged parts.
 - Has enough grease.
 - Has no visible space between the upper and lower fifth-wheel.
 - Locking jaws are around the shank, not the head of the kingpin. See Figure 6.16.
 - Release arm is properly seated and the safety latch/lock is engaged.

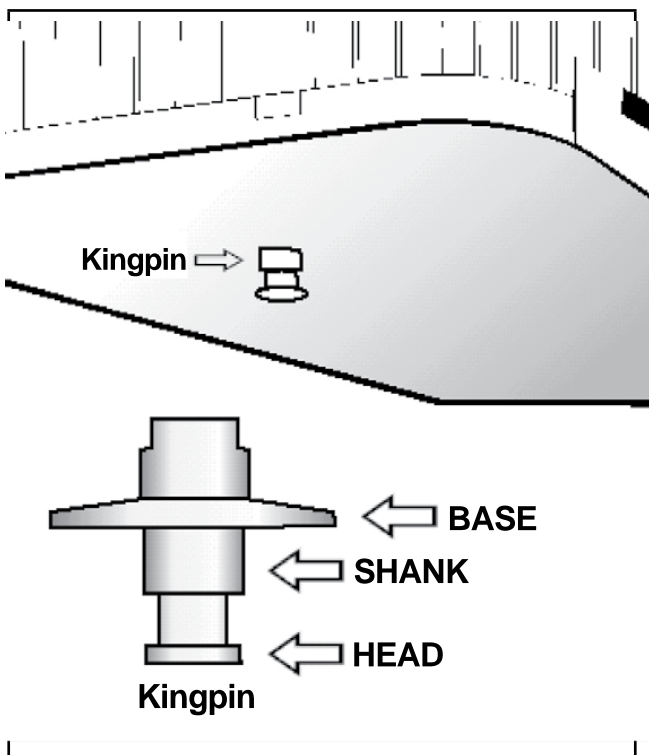

Figure 6.16

- Check the fifth-wheel (upper).
 - Glide plate is securely mounted to the trailer frame.
 - Kingpin is not damaged.
- Check the air and electric lines to the trailer.
 - The electrical cord is firmly plugged in and secured.
 - Air lines are properly connected to the glad hands, no air leaks, and properly secured with enough slack for turns.
 - All lines are free from damage.
- Check the sliding fifth-wheel.
 - The slide is not damaged or parts missing.
 - Is properly greased.
 - All locking pins are present and locked in place.
 - If air powered, there are no air leaks.
 - The fifth-wheel is not so far forward that the tractor frame will hit the landing gear, or the cab will hit the trailer during turns.

Landing Gear

- Is fully raised, has no missing parts, and is not bent or otherwise damaged.
- Crank handle is in place and secured.
- If power operated, there are no air or hydraulic leaks.

6.5.2 – Combination Vehicle Brake Check

Do these checks in addition to Section 5.3: Inspecting Air Brake Systems.

The following section explains how to check air brakes on combination vehicles. Check the brakes on a double or triple trailer as you would any combination vehicle.

- **Check That Air Flows to All the Trailers.**

Use the tractor parking brake and/or chock the wheels to hold the vehicle. Wait for air pressure to reach normal, and then push in the red “trailer air supply” knob. This will supply air to the emergency (supply) lines. Use the trailer handbrake to provide air to the service line. Go to the rear of the rig. Open the emergency line shut-off valve at the rear of the last trailer. You should hear air escaping, showing the entire system is charged. Close the emergency line valve. Open the service line valve to check that service pressure goes through all the trailers (this test assumes that the trailer handbrake or service brake pedal is on), and then close the valve. If you do **not** hear air escaping from both lines, check that the shut-off valves on the trailer(s) and dolly(ies) are in the OPEN position. You **must** have air all the way to the back for all the brakes to work.

- **Test the Tractor Protection Valve.**

Charge the trailer air brake system. (That is, build up normal air pressure and push the “air supply” knob in.) Shut the engine off. Step on and off the brake pedal several times to reduce the air pressure in the tanks. The trailer air supply control (also called the tractor protection valve control) should pop out (or go from “normal” to “emergency” position) when the air pressure falls into the pressure range specified by the manufacturer. (Usually within the range of 20 to 45 psi.)

— If the tractor protection valve does not work right, an air hose or trailer brake leak could drain all the air from the tractor. This would cause the emergency brakes to come on, with possible loss of control.

- **Test the Trailer Emergency Brakes.**

Charge the trailer air brake system and check that the trailer rolls freely. Then stop and pull out the trailer air supply control (also called tractor protection valve control or trailer emergency valve), or place it in the “emergency” position. Pull gently on the trailer with the tractor to check that the trailer emergency brakes are on.

- **Test the Trailer Service Brakes.**

Check for normal air pressure, release the parking brakes, move the vehicle forward slowly, and apply trailer brakes with the hand control (trolley valve), if so equipped. You should feel the brakes come on. This tells you the trailer brakes are connected and working. (The trailer brakes should be tested with the hand valve but controlled in normal operation with the foot pedal, which applies air to the service brakes at all wheels.)



SUBSECTION 6.5

Test Your Knowledge

18. Which shut-off valves should be open and which closed?
19. How can you test that air flows to all trailers?
20. How can you test the tractor protection valve?
21. How can you test the trailer emergency brakes?
22. How can you test the trailer service brakes?

These questions may be on your test. If you cannot answer all of them, reread Subsection 6.5.



Am I Okay TO DRIVE?



***Buzzed Driving
is Drunk Driving***
Designate a sober driver

SECTION 7: DOUBLES AND TRIPLES

THIS SECTION COVERS

- 7.1 – Pulling Double/Triple Trailers
- 7.2 – Coupling and Uncoupling
- 7.3 – Inspecting Doubles and Triples
- 7.4 – Doubles/Triples Air Brake Check

This section has information you need to pass the CDL knowledge test for driving safely with double and triple trailers. It tells about how important it is to be very careful when driving with more than 1 trailer, how to couple and uncouple correctly, and about inspecting doubles and triples carefully. (You should also study Sections 2, 5, and 6.)

NOTE: Triple combinations are **not** legal in California. Triples are discussed in this section because they are legal in many other states.

The endorsement is given by knowledge test only. **Do not bring in a set of doubles** for a Class A skills test.

7.1 – PULLING DOUBLE/TRIPLE TRAILERS

Take special care when pulling 2 and 3 trailers. There are more things that can go wrong, and doubles/triples are less stable than other CMVs. Some areas of concern are discussed below.

7.1.1 – Prevent the Trailer From Rolling Over

To prevent trailers from rolling over, you must steer gently and go slowly around corners, on ramps, off ramps, and curves. A safe speed on a curve for a straight truck or a single trailer combination vehicle may be too fast for a set of doubles or triples.

7.1.2 – Beware of the Crack-the-Whip Effect

Doubles and triples are more likely to turn over than other combination vehicles because of the “crack-the-whip” effect. You must steer gently when pulling trailers. The last trailer in a combination is most likely to turn over. If you do not understand the crack-the-whip effect, study Subsection 6.1.2 of this handbook.

7.1.3 – Inspect Completely

There are more critical parts to check when you have 2 or 3 trailers. Check them all. Follow the procedures described later in this section.

7.1.4 – Look Far Ahead

Doubles and triples must be driven very smoothly to avoid rollover or jackknife. Therefore, look far ahead so you can slow down or change lanes gradually when necessary.

7.1.5 – Manage Space

Doubles and triples take up more space than other CMVs. They are not only longer, but also need more space because they cannot be turned or stopped suddenly. Allow more following distance. Make sure you have large enough gaps before entering or crossing traffic. Be certain you are clear at the sides before changing lanes.

7.1.6 – Adverse Conditions

Be more careful in adverse conditions. In bad weather, slippery conditions, and mountain driving, you must be especially careful if you drive double and triple bottoms. You will have greater length and more dead axles to pull with your drive axles than other drivers. There is more chance for skids and loss of traction.

7.1.7 – Parking the Vehicle

Make sure you do not get in a spot you cannot pull straight through. You need to be aware of how parking lots are arranged in order to avoid a long and difficult escape.

7.1.8 – Anti-lock Braking Systems on Converter Dollies

Converter dollies built on or after March 1, 1998, are required to have anti-lock brakes. These dollies have a yellow lamp on the left side of the dolly.

7.2 – COUPLING AND UNCOUPLING

Knowing how to couple and uncouple correctly is basic to safe operation of doubles and triples. Wrong coupling and uncoupling can be very dangerous. Coupling and uncoupling steps for doubles and triples are listed below.

7.2.1 – Coupling Double Trailers

Secure the Second (Rear) Trailer

If the second trailer does not have spring brakes, drive the tractor close to the trailer, connect the emergency line, charge the trailer air tank, and disconnect the emergency line. This will set the trailer emergency brakes (if the slack adjusters are correctly adjusted). Chock the wheels if you have any doubt about the brakes.

For the safest handling on the road, the more heavily loaded semitrailer should be in first position behind the tractor. The lighter trailer should be in the rear.

A converter gear on a dolly is a coupling device of 1 or 2 axles and a fifth-wheel by which a semitrailer can be coupled to the rear of a tractor-trailer combination forming a double bottom rig. See Figure 7.1.

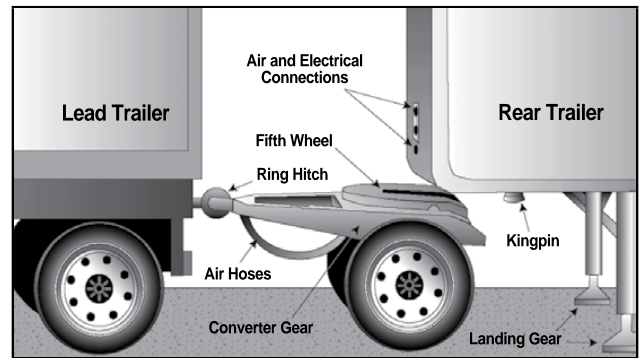

Figure 7.1

Position the Converter Dolly in Front of the Second (Rear) Trailer

- Release the dolly brakes by opening the air tank petcock. Or, if the dolly has spring brakes, use the dolly parking brake control.
- If the distance is not too great, wheel the dolly into position by hand so it is in line with the kingpin.
- Or, use the tractor and the first semitrailer to pick up the converter dolly:
 - Position the combination as close as possible to the converter dolly.
 - Move the dolly to the rear of the first semitrailer and couple it to the trailer.
 - Lock the pintle hook.
 - Secure the dolly support in the raised position.
 - Pull the dolly into position as close as possible to the nose of the second semitrailer.
 - Lower the dolly support.
 - Unhook the dolly from the first trailer.
 - Wheel the dolly into position in front of the second trailer in line with the kingpin.

Connect the Converter Dolly to the Front Trailer

- Back the first semitrailer into position in front of the dolly tongue.
- Hook the dolly to the front trailer.
 - Lock the pintle hook.
 - Secure the converter gear support in the raised position.

Connect the Converter Dolly to the Rear Trailer

- Make sure the trailer brakes are locked and/or the wheels chocked.
- Make sure the trailer height is correct. (It must be slightly lower than the center of the fifth-wheel, so the trailer is raised slightly when the dolly is pushed under.)
- Back the converter dolly under the rear trailer.
- Raise the landing gear slightly off the ground to prevent damage if the trailer moves.
- Test the coupling by pulling against the pin of the second semitrailer.
- Make a visual check of the coupling. (No space between the upper and lower fifth-wheel and the locking jaws are closed on the kingpin.)
- Connect the safety chains, air hoses, and light cords.
- Close the converter dolly air tank petcock and shut-off the valves at the rear of the second trailer (service and emergency shut-offs).
- Open the shut-off valves at the rear of the first trailer (and on the dolly, if so equipped).
- Raise the landing gear completely.
- Charge the trailer brakes (push the “air supply” knob in), and check for air at the rear of the second trailer by opening the emergency line shut-off. If the air pressure is not there, something is wrong and the brakes will not work.

7.2.2 – Uncoupling the Double Trailers

Uncouple the Rear Trailer

- Park the rig in a straight line, on firm level ground.
- Apply the parking brakes so the rig will not move.
- Chock the wheels of the second trailer if it does not have spring brakes.
- Lower the landing gear of the second semitrailer enough to remove some weight from the dolly.
- Close the air shut-offs at the rear of the first semitrailer (and on the dolly, if so equipped).
- Disconnect and secure all dolly air and electric lines.
- Release the dolly brakes.
- Release the converter dolly fifth-wheel latch.
- Slowly pull the tractor, first semitrailer, and dolly forward to pull the dolly out from under the rear semitrailer.

Uncouple the Converter Dolly

- Lower the dolly landing gear.
- Disconnect the safety chains.
- Apply the converter gear spring brakes or chock the wheels.
- Release the pintle hook on the first semi-trailer.
- Slowly pull clear of the dolly.

Never unlock the pintle hook with the dolly still under the rear trailer. The dolly tow bar may fly up, possibly causing injury, and make it very difficult to recouple.

7.2.3 – Coupling and Uncoupling Triple Trailers

Couple the Tractor/First Semitrailer to the Second/Third Trailers

- Couple the tractor to the first trailer. Use the method already described for coupling tractor-semitrailers.
- Move the converter dolly into position and couple the first trailer to the second trailer using the method for coupling doubles. The triples rig is now complete.

Uncouple the Triple-Trailer Rig

- Uncouple the third trailer by pulling the dolly out, and then unhitching the dolly using the method for uncoupling doubles.
- Uncouple the remainder of the rig as you would any double-bottom rig, using the method already described.

REMEMBER: Operating triples is **not** allowed in California.

7.2.4 – Coupling and Uncoupling Other Combinations

The methods described so far apply to more common tractor-trailer combinations. However, there are other ways of coupling and uncoupling the many types of truck-trailer and tractor-trailer combinations that are in use. There are too many to cover in this handbook. You will need to learn the correct way to couple and uncouple the vehicle(s). Drive according to the manufacturer and/or owner specifications.

7.3 – INSPECTING DOUBLES AND TRIPLES

Use the 7-step inspection procedure described in Section 2 to inspect your combination vehicle. There are more things to inspect on a combination vehicle than on a single vehicle. Many of these items are simply more of what you would find on a single vehicle. (For example, tires, wheels, lights, reflectors, etc.) There are also some new things to check. These are discussed below.

7.3.1 – Additional Checks

Do these checks in addition to those already listed in Section 2, Step 5: Do a Walk Around Inspection.

Coupling System Areas

- Check the fifth-wheel (lower).
 - Is securely mounted to the frame.
 - Has no missing or damaged parts.
 - Has enough grease.
 - Has no visible space between the upper and lower fifth-wheel.
 - Locking jaws are around the shank, not the head of the kingpin.
 - Release arm is properly seated and the safety latch/lock is engaged.
- Check the fifth-wheel (upper).
 - Glide plate is securely mounted to the trailer frame.
 - Kingpin is not damaged.
- Air and electric lines to the trailer.
 - Electrical cord is firmly plugged in and secured.
 - Air lines are properly connected to the glad hands, with no air leaks, and properly secured with enough slack for turns.
 - All lines are free from damage.
- Sliding the fifth-wheel.
 - Slide is not damaged or parts missing.
 - Is properly greased.
 - All locking pins are present and locked in place.
 - If air powered, there are no air leaks.
 - Check that the fifth-wheel is not so far forward that the tractor frame will hit the landing gear, or the cab will hit the trailer during turns.

Landing Gear

- Is fully raised, has no missing parts, not bent, or otherwise damaged.
- Crank handle is in place and secured.
- If power operated, there are no air or hydraulic leaks.

Double and Triple Trailers

- Shut off the valves (at the rear of the trailers, in service and emergency lines).
 - The rear of the front trailers: OPEN.
 - The rear of the last trailer: CLOSED.
 - The converter dolly air tank drain valve: CLOSED.
- Be sure the air lines are supported and the glad hands are properly connected.
- If a spare tire is carried on the converter gear (dolly), make sure it is secured.
- Be sure the pintle-eye of the dolly is in place in the pintle hook of the trailer(s).
- Make sure the pintle hook is latched.
- The safety chains should be secured to the trailer(s).
- Be sure the light cords are firmly connected in the sockets on the trailers.

7.3.2 – Additional Things to Check During a Walk Around Inspection

Do these checks in addition to Section 5, Inspecting Air Brake Systems.

7.4 – DOUBLES/TRIPLES AIR BRAKE CHECK

Check the brakes on a double or triple trailer as you would any combination vehicle. Section 6 explains how to check air brakes on combination vehicles. You must also make the following checks on your double or triple trailers.

7.4.1 – Additional Air Brake Checks

Check That Air Flows to all the Trailers (Double and Triple Trailers)

Use the tractor parking brake and/or chock the wheels to hold the vehicle. Wait for the air pressure to reach normal, and then push in the red “trailer air supply” knob. This will supply air to the emergency (supply) lines. Use the trailer handbrake to provide air to the service line. Go to the rear of the rig. Open the emergency line shut-off valve at the rear of the last trailer. You should hear air escaping, showing the entire system is charged. Close the emergency line valve. Open the service line valve to check that service pressure goes through all the trailers (this test assumes that the trailer handbrake or service brake pedal is on), and then close the valve. If you do **not** hear air escaping from both lines, check that the shut-off valves on the trailer(s) and dolly(ies) are in the OPEN position. You **must** have air all the way to the back for all the brakes to work.

Test the Tractor Protection Valve

Charge the trailer air brake system (build up normal air pressure and push the “air supply” knob in). Shut the engine off. Step on and off the brake pedal several times to reduce the air pressure in the tanks. The trailer air supply control (also called the tractor protection valve control) should pop out (or go from the “normal” to “emergency” position) when the air pressure falls into the pressure range specified by the manufacturer (usually within the range of 20 to 45 psi).

If the tractor protection valve does not work properly, an air hose or trailer brake leak could drain all the air from the tractor. This would cause the emergency brakes to come on, with possible loss of control.

Test the Trailer Emergency Brakes

Charge the trailer air brake system and check that the trailer rolls freely. Then stop and pull out the trailer air supply control (also called tractor protection valve control or trailer emergency valve) or place it in the “emergency” position. Pull gently on the trailer with the tractor to check that the trailer emergency brakes are on.

Test the Trailer Service Brakes

Check for normal air pressure, release the parking brakes, move the vehicle forward slowly, and apply trailer brakes with the hand control (trolley valve), if so equipped. You should feel the brakes come on. This tells you the trailer brakes are connected and working. (The trailer brakes should be tested with the hand valve, but controlled in normal operation with the foot pedal, which applies air to the service brakes at all wheels.)

SECTION 7

Test Your Knowledge

1. What is a converter dolly?
2. Do converter dollies have spring brakes?
3. What 3 methods can you use to secure a second trailer before coupling?
4. How do you check to make sure trailer height is correct before coupling?
5. What do you check when making a visual check of coupling?
6. Why should you pull a dolly out from under a trailer before you disconnect it from the trailer in front?
7. What should you check for when inspecting the converter dolly? The pintle hook?
8. Should the shut-off valves on the rear of the last trailer be open or closed? On the first trailer in a set of doubles? On the middle trailer of a set of triples?
9. How can you test that air flows to all trailers?
10. How do you know if your converter dolly is equipped with anti-lock brakes?

These questions may be on your test. If you cannot answer them all, reread Section 7.

SECTION 8: TANK VEHICLES

THIS SECTION COVERS

- 8.1 – Inspecting Tank Vehicles
- 8.2 – Driving Tank Vehicles
- 8.3 – Safe Driving Rules

This section has information needed to pass the CDL knowledge test for driving a tank vehicle (tanker). You should also study Sections 2, 5, 6, and 9. An “N” endorsement is required for certain vehicles that transport liquids or gases. The liquid or gas does not have to be a HazMat. An “N” endorsement is required if your vehicle needs a Class A, B, or C CDL and you want to haul a liquid or liquid gas in a tank or tanks having an individual rated capacity of more than 119 gallons and an aggregate rated capacity of 1,000 gallons or more that is either permanently or temporarily attached to the vehicle or chassis.

A CMV transporting an empty storage container tank not designed for transportation, with a rated capacity of at least 1,000 gallons that is temporarily attached to a flatbed trailer, is not a tank vehicle (CVC §15210(r)).

Before loading, unloading, or driving a tanker, inspect the vehicle. This makes sure that the vehicle is safe to carry the liquid or gas and is safe to drive.

A CLP holder with an “N” endorsement is prohibited from operating a tank vehicle unless it is empty. In addition, if the tanker previously contained HazMat, it must be purged (FMCSR §383.25).

If an applicant applies for a Class C CDL with an “N” endorsement **only**, a commercial skills test is required. The applicant must be tested in a representative Class C CMV designed to transport any liquid or gaseous materials in a tank or tanks having an individual rated capacity of more than 119 gallons and an aggregate rated capacity of 1,000 gallons or more that is permanently or temporarily attached to the vehicle or chassis.

An “N” endorsement may be added to an existing Class C CDL with the completion of all applicable knowledge tests; the commercial skills test is **not** required.

8.1 – INSPECTING TANK VEHICLES

Tank vehicles have special items that you need to check. Tank vehicles come in many types and sizes. You need to check the vehicle’s operator manual to make sure you know how to inspect your tank vehicle.

8.1.1 – Leaks

On all tank vehicles, the most important item to check for is leaks. Check under and around the vehicle for signs of any leaking. Do not carry liquids or gases in a leaking tank. To do so is a crime. You will be cited and prevented from driving further. You may also be liable for the cleanup of any spill. In general, check the following:

- Check the tank’s body or shell for dents or leaks.
- Check the intake, discharge, and cut-off valves. Make sure the valves are in the correct position before loading, unloading, or moving the vehicle.
- Check pipes, connections, and hoses for leaks, especially around joints.
- Check manhole covers and vents. Make sure the covers have gaskets and they close correctly. Keep the vents clear so they work correctly.

8.1.2 – Check Special Purpose Equipment

If your vehicle has any of the following equipment, make sure it works:

- Vapor recovery kits.
- Grounding and bonding cables.
- Emergency shutoff systems.
- Built in fire extinguisher.

Never drive a tank vehicle with open valves or manhole covers.

8.1.3 – Special Equipment

Check the emergency equipment required for your vehicle. Find out what equipment you are required to carry and make sure you have it (and it works).

8.2 – DRIVING TANK VEHICLES

Hauling liquids in tanks requires special skills because of the high center of gravity and liquid movement. See Figure 8.1.

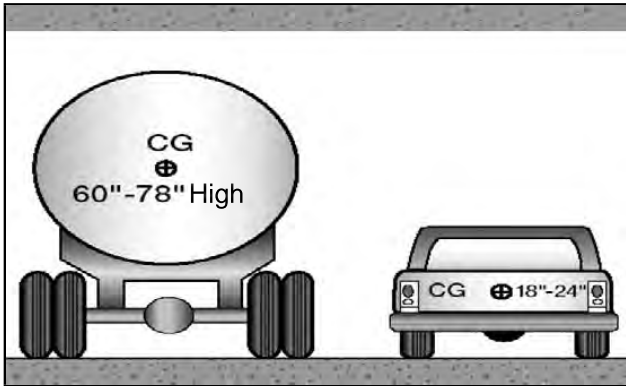

Figure 8.1

8.2.1 – High Center of Gravity

High center of gravity means that much of the load's weight is carried high up off the road. This makes the vehicle top-heavy and easy to roll over. Liquid tankers are especially easy to roll over. Tests have shown that tankers can turn over at the speed limits posted for curves. Take highway curves and on ramp/off ramp curves well below the posted speeds.

8.2.2 – Danger of Surge

Liquid surge results from movement of the liquid in partially filled tanks. This movement can have bad effects on handling. For example, when coming to a stop, the liquid will surge back and forth. When the wave hits the end of the tank, it tends to push the truck in the direction the wave is moving. If the truck is on a slippery surface, such as ice, the wave can shove a stopped truck out into an intersection. The driver of a liquid tanker must be very familiar with handling the vehicle.

8.2.3 – Bulkheads

Some liquid tanks are divided into several smaller tanks by bulkheads. When loading and unloading smaller tanks, the driver must pay attention to weight distribution. Do not put too much weight on the front or rear of the vehicle.

8.2.4 – Baffled Tanks

Baffled liquid tanks have bulkheads in them with holes that let the liquid flow through. The baffles help to control the forward and backward liquid surge. Side-to-side surge can still occur and cause a roll over.

8.2.5 – Unbaffled Tanks

Unbaffled liquid tankers (sometimes called "smooth bore" tanks) have nothing inside to slow down the flow of the liquid. Therefore, forward-and-back surge is very strong. Unbaffled tanks are usually those that transport food products (milk, for example). (Sanitation regulations forbid the use of baffles because of the difficulty in cleaning the inside of the tank.) Be extremely cautious (slow and careful) in driving smooth bore tanks, especially when starting and stopping.

8.2.6 – Outage

Never load a cargo tank totally full. Liquids expand as they warm and you must leave room for the expanding liquid. This is called "outage." Since different liquids expand by different amounts, they require different amounts of outage. You must know the outage requirement when hauling liquids in bulk.

8.2.7 – How Much to Load?

A full tank of dense liquid (such as some acids) may exceed legal weight limits. For that reason, you may often only partially fill tanks with heavy liquids. The amount of liquid to load into a tank depends on:

- The amount the liquid will expand in transit.
- The weight of the liquid.
- Legal weight limits.
- The temperature of the load.

8.2.8 – Speeding in a Tank Vehicle

If you are driving a tank vehicle transporting more than 500 gallons of flammable liquid at a speed greater than the applicable speed limit or in willful or wanton disregard for the safety of persons or property, in addition to any other applicable penalty, you are subject to a fine for a first offense. For a second or subsequent offense within 2 years of a prior offense, you are subject to a fine and suspension of up to 6 months of a HazMat or cargo “N” endorsement, or both (CVC §22406.5).

8.2.9 – Hours of Service in a Tank Vehicle

The maximum driving time within a work period is 10 hours for drivers of tank vehicles with a capacity greater than 500 gallons when transporting flammable liquid (CVC §34501.2(b)(1)).

8.3 – SAFE DRIVING RULES

In order to drive tank vehicles safely, you must remember to follow all the safe driving rules. A few of these rules are:

8.3.1 – Drive Smoothly

Because of the high center of gravity and the surge of the liquid, you must start, slow down, and stop very smoothly. Also, make smooth turns and lane changes.

8.3.2 – Controlling Surge

- Keep a steady pressure on the brakes. Do not release the brakes too soon when coming to a stop.
- Brake far in advance of a stop and increase your following distance.
- If you must make a quick stop to avoid an accident, use controlled or stab braking. If you do not remember how to stop using these methods, review Section 2. Also, remember that if you steer quickly while braking, your vehicle may roll over.

8.3.3 – Curves

Slow down before curves, and then accelerate slightly through the curve. The posted speed for a curve may be too fast for a tank vehicle.

8.3.4 – Stopping Distance

Keep in mind how much space you need to stop your vehicle. Remember that wet roads double the normal stopping distance. Empty tank vehicles may take longer to stop than full ones.

8.3.5 – Skids

Do not over steer, accelerate, or brake. If you do, your vehicle may skid. On tank trailers, if your drive or trailer wheels begin to skid, your vehicle may jack-knife. When any vehicle starts to skid, you must take action to restore traction to the wheels.

////////////////////////////////////

SECTION 8

Test Your Knowledge

1. How are bulkheads different than baffles?
2. Should a tank vehicle take curves, on ramps, or off ramps at the posted speed limits?
3. How are smooth bore tankers different to drive than those with baffles?
4. What 3 things determine how much liquid you can load?
5. What is outage?
6. How can you help control surge?
7. What 2 reasons make special care necessary when driving tank vehicles?

These questions may be on the test. If you cannot answer them all, reread Section 8.

////////////////////////////////////

DMV KIOSKS Offer Convenient Transactions

Available at:

Grocery Stores
DMV Offices
Auto Clubs



Find a kiosk near you
dmv.ca.gov/kiosks

- ✓ Complete your vehicle registration renewal
- ✓ Receive a replacement registration card or sticker
- ✓ Submit proof of insurance
- ✓ File for planned nonoperation (PNO) status
- ✓ Obtain your driver's record and vehicle record
- ✓ Receive a replacement driver's license and more . . .

SECTION 9: HAZARDOUS MATERIALS

THIS SECTION COVERS

- 9.1 – Intent of the Regulations
 - 9.2 – Hazardous Materials Transportation—
Who Does What
 - 9.3 – Communication Rules
 - 9.4 – Loading and Unloading
 - 9.5 – Bulk Packaging Marking, Loading,
and Unloading
 - 9.6 – Hazardous Materials — Driving and
Parking Rules
 - 9.7 – Hazardous Materials — Emergencies
 - 9.8 – Hazardous Materials — Glossary
-

This section is designed to assist you in understanding your role and responsibilities in hauling HazMat. HazMat are products that pose a risk to health, safety, and property during transportation. The term often is shortened to HazMat, which you may see on road signs or to HM in government regulations. HazMat include explosives, various types of gas, solids, flammable and combustible liquid, and other materials. Because of the risks involved and the potential consequences these risks impose, all levels of government regulate the handling of HazMat.

NOTE: To ensure public safety, DMV examiners will not conduct commercial skills tests in vehicles displaying vehicle placards per CVC §27903. This includes vehicles carrying HazMat and/or wastes and vehicles which have not been purged of their hazardous cargo. CVC §15278(a)(4) requires an “H” endorsement for those who drive a vehicle requiring placards.

Your CDL tests will be based on your knowledge of federal transportation requirements. Text preceded by “California” refers to state (nonfederal) requirements which also apply when driving in California. The state requirements are strictly enforced.

The *Hazardous Materials Regulations* (HMR) and common references are found in CFR, Title 49, Parts 171–180.

The Hazardous Materials Table in the regulations contains a list of these items. However, this list is not all-inclusive. Whether or not a material is considered hazardous is based on its characteristics and the shipper’s decision on whether or not the material meets a definition of a HazMat in the regulations. Due to the constantly changing nature of government regulations, it is impossible to guarantee absolute accuracy of the materials in this section. It is essential for you to have an up-to-date copy of the complete regulations. Included in these regulations is a complete glossary of terms.

The regulations require vehicles transporting certain types or quantities of HazMat to display diamond-shaped, square on point, warning signs called placards.

You must have a CDL with an “H” endorsement before you drive any size vehicle that is used to transport HazMat as defined in CFR, Title 49 §383.5. You must pass a knowledge test about the regulations and requirements to get this endorsement.

NOTE: A CLP holder is prohibited from transporting HazMat.

Everything you need to know to pass the knowledge test is in this section. However, this is only the beginning. Most drivers need to know much more on the job. You can learn more by reading and understanding the federal and state rules applicable to HazMat, as well as attending HazMat training courses. Your employer, colleges, universities, and various associations usually offer these courses. You can get copies of the *Federal Regulations* (CFR, Title 49) through your local government printing office bookstore and various industry publishers. Union or company offices often have copies of the rules for driver use. Find out where you can get your own copy to use on the job.

The regulations require training and testing for all drivers involved in transporting HazMat. Your employer or a designated representative is required to provide this training and testing. HazMat employers are required to keep a record of training for each employee as long as that employee is working with HazMat, and for 90 days thereafter. The regulations require that HazMat employees be trained and tested at least once every 3 years.

All drivers must be trained in the security risks of HazMat transportation. This training must include how to recognize and respond to possible security threats.

The regulations also require that drivers have special training before driving a vehicle transporting certain flammable gas materials or highway-route controlled quantities of radioactive materials. In addition, drivers transporting cargo tanks and portable tanks must receive specialized training. Each driver's employer or their designated representative must provide such training.

Some locations require permits to transport certain explosives or bulk hazardous wastes. States and counties also may require drivers to follow special HazMat routes. The federal government may require permits or exemptions for special HazMat cargo such as rocket fuel. Find out about permits, exemptions, and special routes for the places you drive.

Permits. A permit or route restriction may be required to transport some classifications and quantities of HazMat. Contact CHP and DOT for information. Permits and registrations may also be required for hazardous and medical waste transportation. Contact the Department of Toxic Substances Control and the Department of Health Services respectively, for information.

If you apply for an original or renew an "H" endorsement, you must undergo a TSA federal security threat assessment (background records check). You start the TSA background records check after you apply for your CDL at DMV, successfully complete all appropriate knowledge tests, and submit a valid medical form. You must submit fingerprints, a fee, and any additional information required to one of TSA's designated agents. You must also provide the TSA agent with a copy of your CDL permit and 1 of the following ID documents:

- A California DL/ID card.
- An out-of-state DL.
- Your CLP accompanied by a DMV photo receipt.

For a list of TSA agent sites, visit universalenroll.dhs.gov or call 1-855-347-8371.

California Hazardous Materials Transportation License. Every motor carrier who transports the following HazMat in California must have a Hazardous Materials transportation license issued by CHP (CVC §32000.5):

- HazMat shipments (unless specifically excepted) for which the display of placards is required per CVC §27903.
- HazMat shipments in excess of 500 pounds, transported for a fee, which would require placarding if shipped in greater amounts in the same manner.

A valid legible copy of the carrier's HazMat transportation license must be carried in the vehicle and be presented to any peace officer or duly authorized employee of CHP upon request (CCR, Title 13 §1160.3(g)(2)).

This is in addition to the federal HazMat registration that may be required under CFR, Title 49 §107.601.

9.1 – INTENT OF THE REGULATIONS

9.1.1 – Contain the Material

Transporting HazMat can be risky. The regulations are intended to protect you, those around you, and the environment. They tell shippers how to package the materials safely and drivers how to load, transport, and unload the material. These are called “containment rules.”

9.1.2 – Communicate the Risk

Shippers must warn drivers and others about the material’s hazards to communicate the risk. The regulations require shippers to put hazard warning labels on packages, provide proper shipping papers, emergency response information, and placards. These steps communicate the hazard to the shipper, carrier, and driver.

9.1.3 – Assure Safe Drivers and Equipment

You must pass a knowledge test about transporting HazMat to get an “H” endorsement on a CDL. To pass the test, you must know how to:

- Identify what is HazMat.
- Safely load shipments.
- Properly placard your vehicle in accordance with the rules.
- Safely transport shipments.

Learn the rules and follow them. Following the rules reduces the risk of injury from HazMat. Taking shortcuts by breaking rules is unsafe. Noncompliance with regulations can result in fines and jail.

Inspect your vehicle before and during each trip. Law enforcement officers may stop and inspect your vehicle. When stopped, they may check your shipping papers, vehicle placards, CDL “H” endorsement, and your knowledge of HazMat.

9.2 – HAZARDOUS MATERIALS TRANSPORTATION—WHO DOES WHAT

9.2.1 – The Shipper

- Sends products from one place to another by truck, rail, vessel, or airplane.
- Uses the HazMat regulations to determine the products:
 - ID number.
 - Proper shipping name.
 - Hazard class.
 - Packing group.
 - Correct packaging.
 - Correct label and markings.
 - Correct placards.
- Must package, mark, and label the materials; prepare shipping papers; provide emergency response information; and supply placards.
- Must certify on the shipping paper that the shipment has been prepared according to the rules (unless you are pulling cargo tanks supplied by you or your employer).

9.2.2 – The Carrier

- Takes the shipment from the shipper to its destination.
- Prior to transportation, checks that the shipper correctly described, marked, labeled, and otherwise prepared the shipment for transportation.
- Refuses improper shipments.

9.2.3 – The Driver

- Makes sure the shipper identified, marked, and labeled the HazMat properly.
- Refuses leaking packages and shipments.
- Placards the vehicle when loading, if required.
- Safely transports the shipment without delay.
- Follows all special rules about transporting HazMat.
- Keeps HazMat shipping papers and emergency response information in the proper place.
- Reports accidents and incidents involving HazMat to the proper government agency, when the accident/incident occurs while the driver is in physical control of the shipment.

9.3 – COMMUNICATION RULES

9.3.1 – Definitions

Some words and phrases have special meanings when talking about HazMat. Some of these may differ from meanings you are used to. The words and phrases in this section may be on your test. The meanings of other important words are in the Glossary at the end of Section 9.

A material's hazard class reflects the risks associated with it. There are 9 different hazard classes. The types of materials included in these 9 classes are in Figure 9.1.

A shipping paper describes the HazMat being transported. Shipping orders, bills of lading, and manifests are all shipping papers. Figure 9.6 shows an example of a shipping paper.

HAZARDOUS MATERIALS CLASS			
Class	Division	Name of Class or Division	Examples
1	1.1	Mass Explosion	Dynamite
	1.2	Projection Hazard	Flares
	1.3	Fire Hazard	Display Fireworks
	1.4	Minor Explosion	Ammunition
	1.5	Very Insensitive	Blasting Agents
	1.6	Extremely Insensitive	Explosive Devices
2	2.1	Flammable Gases	Propane
	2.2	Non-Flammable Gases	Helium
	2.3	Poisonous/Toxic Gases	Fluorine, Compressed
3	-	Flammable Liquids	Gasoline
4	4.1	Flammable Solids	Ammonium
	4.2	Spontaneously Combustible	Picrate, Wetted White Phosphorus
	4.3	Dangerous When Wet	Sodium
5	5.1	Oxidizers	Ammonium Nitrate
	5.2	Organic Peroxides	Methyl Ethyl Ketone Peroxide
6	6.1	Poison (Toxic Material)	Potassium Cyanide
	6.2	Infectious Substances	Anthrax Virus
7	-	Radioactive	Uranium
8	-	Corrosives	Battery Fluid
9	-	Miscellaneous HazMat	Polychlorinated Biphenyls (PCB)
None	-	ORM-D (Other Regulated Material-Domestic)	Food Flavorings, Medicines
	-	Combustible Liquids	Fuel Oil

Figure 9.1

After an accident or HazMat spill or leak, you may be injured and unable to communicate the hazards of the materials you are transporting. Firefighters and police can prevent or reduce the amount of damage or injury at the scene if they know what HazMat is being carried. Your life, and the lives of others, may depend on quickly locating the HazMat shipping papers. For that reason the rules require:

- Shippers to describe HazMat correctly and include an emergency response telephone number on shipping papers.
- Carriers and drivers to quickly identify HazMat shipping papers, or keep them on top of other shipping papers and keep the required emergency response information with the shipping papers.
- Drivers to keep HazMat shipping papers in or on:
 - A pouch on the driver's door.
 - Clear view within immediate reach while the seat belt is fastened while driving.
 - The driver's seat when out of the vehicle.

9.3.2 – Package Labels

Shippers put diamond-shaped hazard warning labels on most HazMat packages. These labels inform others of the hazard. If the diamond label will not fit on the package, shippers may put the label on a tag securely attached to the package. For example, compressed gas cylinders that will not hold a label will have tags or decals. Figure 9.2 shows examples of labels.



Figure 9.2
Examples of HazMat Labels.

9.3.3 – Lists of Regulated Products

Placards. Placards are used to warn others of HazMat. Placards are signs put on the outside of a vehicle and on bulk packages, which identify the hazard class of the cargo. A placarded vehicle must have at least 4 identical placards. They are put on the front, rear, and both sides of the vehicle. See Figure 9.3. Placards must be readable from all 4 directions. They are at least 9.84 inches (250mm) square, square-on-point, in a diamond shape. Cargo tanks and other bulk packaging display the ID number of their contents on placards or orange panels or white square-on-point displays that are the same size as placards.

ID numbers are a 4-digit code used by first responders to identify HazMat. An ID number may be used to identify more than 1 chemical. The letters “NA” or “UN” will precede the ID number. The U.S. DOT *Emergency Response Guidebook* (ERG) lists the chemicals and the ID numbers assigned to them.

There are 3 main lists used by shippers, carriers, and drivers when trying to identify HazMat. Before transporting a material, look for its name on 3 lists. Some materials are on all lists, others on only one. Always check the following lists:

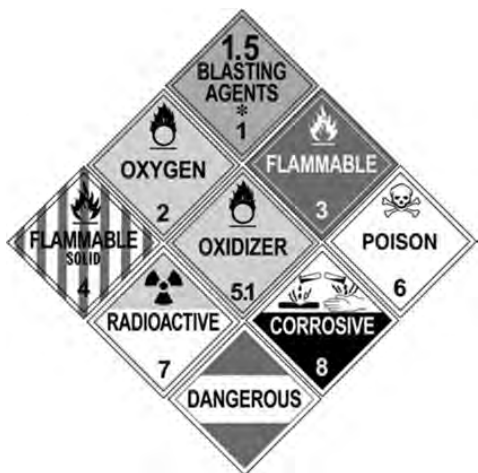

Figure 9.3
Examples of HazMat Placards.

- CFR, Title 49 §172.101, Hazardous Materials Table.
- Appendix A to CFR, Title 49 §172.101, List of Hazardous Substances and Reportable Quantities.
- Appendix B to CFR, Title 49 §172.101, List of Marine Pollutants.

Hazardous Materials Table. Figure 9.4 shows part of the Hazardous Materials Table. Column 1 tells which shipping mode(s) the entry affects and other information concerning the shipping description. The next 5 columns show each material’s shipping name, hazard class or division, ID number, packaging group, and required labels.

Column 1: 6 different symbols may appear in Column 1 of the table.

- (+) Shows the proper shipping name, hazard class, and packing group to use, even if the material does not meet the hazard class definition.
- (A) Means the HazMat described in Column 2 is subject to HMR only when offered or intended for transport by air unless it is a hazardous substance or waste.
- (W) Means the HazMat described in Column 2 is subject to HMR only when offered or intended for transportation by water unless it is a hazardous substance, waste, or marine pollutant.
- (D) Means the proper shipping name is appropriate for describing materials for domestic transportation, but may not be proper for international transportation.
- (I) Identifies a proper shipping name that is used to describe materials in international transportation. A different shipping name may be used when only domestic transportation is involved.
- (G) Means the HazMat described in Column 2 is a generic shipping name. A generic shipping name must be accompanied by a technical name on the shipping paper. A technical name is a specific chemical that makes the product hazardous.

CFR, TITLE 49 §172.101 HAZARDOUS MATERIALS TABLE									
Symbols	HazMat Description & Proper Shipping Names	Hazard Class or Division	Identification Numbers	PG	Label Codes	Special Provisions (172.102)	Packaging (173.***)		
							Exceptions	Non Bulk	Bulk
(1)	(2)	(3)	(4)	(5)	(6)	(7)	(8A)	(8B)	(8C)
A	Acetaldehyde ammonia	9	UN1841	III	9	IB8, IP3, IP7, T1, TP33	155	204	240

Figure 9.4

Column 2: lists the proper shipping names and descriptions of regulated materials. Entries are in alphabetical order so you can quickly find the right entry. The table shows proper shipping names in regular type. The shipping paper must show proper shipping names. Names shown in italics are not proper shipping names.

Column 3: shows a material’s hazard class or division, or the entry “Forbidden.” Never transport a “Forbidden” material. Placard HazMat shipments are based on the quantity and hazard class. You can decide which placards to use if you know these 3 things:

- Material’s hazard class.
- Amount being shipped.
- Amount of all HazMat of all classes on your vehicle.

Column 4: lists the ID number for each proper shipping name. ID numbers are preceded by the letters “UN,” or “NA,” or “ID.”

The letters “NA” are associated with proper shipping names that are only used within the U.S. and to and from Canada. The letters “ID” are associated with proper shipping names recognized by the International Civil Aviation Organization (IACO) technical instructions for transportation by air. The ID number must appear on the shipping paper as part of the shipping description and also appear on the package. It also must appear on cargo tanks and other bulk packaging. Police and firefighters use this number to quickly identify the HazMat.

Column 5: shows the packing group (in Roman numerals) assigned to a material.

Column 6: shows the hazard warning label(s) shippers must put on packages of HazMat. Some products require use of more than 1 label due to multiple hazards being present.

Column 7: lists the additional (special) provisions that apply to this material. When there is an entry in this column, you must refer to the CFR for specific information. The numbers 1–6 in this column mean the HazMat is a POISON INHALATION HAZARD. POISON INHALATION HAZARD materials have special requirements for shipping papers, marking, and placards.

Column 8: is a 3-part column showing the section numbers covering the packaging requirements for each HazMat.

NOTE: Columns 9 and 10 do not apply to transportation by highway.

Appendix A to CFR, Title 49 §172.101–List of Hazardous Substances and Reportable Quantities. DOT and EPA want to know about spills of hazardous substances. They are named in the List of Hazardous Substances and Reportable Quantities. See Figure 9.5. Column 3 of the list shows each product’s reportable quantity (RQ). When these materials are being transported in an RQ or greater in 1 package, the shipper displays the letters RQ on the shipping paper and package. The letters RQ may appear before or after the basic description. You or your employer must report any spill of these materials, which occurs in an RQ.

APPENDIX A TO 49 CFR §172.101 LIST OF HAZARDOUS SUBSTANCES AND REPORTABLE QUANTITIES	
<i>Hazardous Substances</i>	<i>Reportable Quantity (RQ) Pounds (Kilograms)</i>
Phenyl mercaptan	100 (45.4)
Phenylmercury acetate	100 (45.4)
Phenylthiourea	100 (45.4)
Phorate	10 (4.54)
Phosgene	10 (4.54)
Phosphine	100 (45.4)
Phosphoric acid	5,000 (2270)
Phosphoric acid, diethyl 4-nitrophenyl ester	100 (45.4)
Phosphoric acid, lead (+2) Salt (2:3) salt	10 (.454)

Figure 9.5

If the words INHALATION HAZARD appear on the shipping paper or package, the rules require display of the POISON INHALATION HAZARD or POISON GAS placards, as appropriate. These placards must be used in addition to other placards, which may be required by the product’s hazard class. Always display the hazard class and POISON INHALATION HAZARD placards, even for small amounts.

Appendix B to CFR, Title 49 §172.101–List of Marine Pollutants. Appendix B is a list of chemicals that are toxic to marine life. For highway transportation, this list is only used for chemicals in a container with a capacity of 119 gallons or more without a placard or label as specified by HMR.

Any bulk packages of a MARINE POLLUTANT must display the MARINE POLLUTANT marking (white triangle with a fish and an “X” through the fish). This marking (it is not a placard) must also be displayed on the outside of the vehicle. In addition, a notation must be made on the shipping papers near the description of the material: MARINE POLLUTANT.

9.3.4 – Shipping Paper

The shipping paper shown in Figure 9.6 describes a shipment. A shipping paper for HazMat must include:

- Page numbers if the shipping paper has more than 1 page. The first page must tell the total number of pages. For example, “Page 1 of 4.”
- A proper shipping description for each HazMat.
- A shipper’s certification, signed by the shipper, saying they prepared the shipment according to HMR.

9.3.5 – Item Description

If a shipping paper describes both hazardous and non-hazardous products, the HazMat must be:

- Entered first.
 - Highlighted in a contrasting color.
- OR
- Identified by an “X” placed before the shipping description (ID#, shipping name, hazard class, packing group) in a column titled “HM.” The letters “RQ” may be used instead of “X” if a reportable quantity needs to be identified.

The basic description of HazMat includes the ID number, proper shipping name, hazard class or division, and packing group, if any, in that order. The packing group is displayed in Roman numerals and may be preceded by “PG.”

SHIPPING PAPER			
TO: <i>ABC Corporation 88 Valley Street Anywhere, VA</i>		FROM: <i>DEF Corporation 55 Mountain Street Nowhere, CO</i>	
		<i>Page 1 of 1</i>	
<i>Quantity</i>	<i>HM</i>	<i>Description</i>	<i>Weight</i>
1 cylinder	RQ	UN1076, Phosgene, 2.3, Poison, Inhalation Hazard, Zone A	25 lbs
("RQ" means that this is a reportable quantity.)		((UN1076 is the Identification Number from Column 4 of the Hazardous Materials Table.) Phosgene is the proper shipping name from Column 2 of the Hazardous Materials Table.) (2.3 is the hazard class from Column 3 of the Hazardous Materials Table.)	
This is to certify that the above named materials are properly classified, described, packaged marked and labeled, and are in proper condition for transportation according to the applicable regulations of the Department of Transportation.			
Shipper: <i>DEF Corporation</i>		Carrier: <i>Safety First</i>	
Per: <i>Smith</i>		Per:	
Date: <i>October 15, 2003</i>		Date:	
Special Instructions: 24 Hour Emergency Contact, John Smith 1-800-555-5555			

Figure 9.6

The ID number, shipping name, and hazard class must not be abbreviated unless specifically authorized in HMR. The description must also show:

- The total quantity and unit of measure.
- The number and type of packages (example: “6 Drums”).
- The letters “RQ,” if a reportable quantity.
- If the letters “RQ” appear, the name of the hazardous substance (if not included in the shipping name).
- For all materials with the letter “G” (Generic) in Column 1, the technical name of the HazMat.

Shipping papers also must list an emergency response telephone number (unless excepted). The emergency response telephone number is the responsibility of the shipper. It can be used by emergency responders to obtain information about any HazMat involved in a spill or fire. The telephone number must be:

- The number of the person offering the HazMat for transportation (if the shipper/officer is the emergency response information [ERI] provider).
OR
- The number of an agency or organization capable of, and accepting responsibility for, providing the detailed information required. The person who is registered with the ERI provider must be identified on the shipping paper by name, contract number, or other unique identifier assigned by the ERI provider.

Shippers also must provide emergency response information to the motor carrier for each HazMat being shipped. The emergency response information must be able to be used away from the motor vehicle and provide information on how to safely handle incidents involving the material. At a minimum, it must include the following information:

- The basic description and technical name.
- Immediate hazards to health.
- Risks of fire or explosion.
- Immediate precautions to be taken in the event of an accident or incident.
- Immediate methods for handling fires.
- Initial methods for handling spills or leaks in the absence of fires.
- Preliminary first aid measures.

Such information can be on the shipping paper or some other document that includes the basic description and technical name of the HazMat. It also may

be in a guidance book, such as the *Emergency Response Guidebook* (ERG). Motor carriers may assist shippers by keeping an ERG on each vehicle carrying HazMat. The driver must provide the emergency response information to any federal, state, or local authority responding to or investigating a HazMat incident.

Total quantity, number, and type of packages must appear before or after the basic description. The packaging type and the unit of measurement may be abbreviated. For example:

10 ctns., UN1263, Paint, 3, PG II, 500 pounds.

The shipper of hazardous wastes must put the word WASTE before the proper shipping name of the material on the shipping paper (hazardous waste manifest). For example:

UN1090, Waste Acetone, 3, PG II.

A nonhazardous material may not be described by using a hazard class or ID number.

Shippers must keep a copy of shipping papers (or an electronic image) for a period of 2 years (3 years for hazardous waste) after the material is accepted by the initial carrier.

If a shipper provides a carrier service only and is not the originator of the shipment, a carrier is required to keep a copy of the shipping paper (or an electronic image) for a period of 1 year.

IMPORTANT: To view complete regulatory requirements for the transportation of HazMat, refer to CFR, Title 49, Parts 171–180.

9.3.6 – Shipper’s Certification

When the shipper packages HazMat, they certify that the package has been prepared according to HMR. The signed shipper’s certification appears on the original shipping paper. The only exceptions are when a shipper is a private carrier transporting their own product and when the package is provided by the carrier (for example, a cargo tank). Unless a package is clearly unsafe or does not comply with HMR, you may accept the shipper’s certification concerning proper packaging. Some carriers have additional rules about transporting HazMat. Follow your employer’s rules when accepting shipments.

9.3.7 – Package Markings and Labels

Shippers print required markings directly on the package, an attached label, or tag. An important package marking is the name of the HazMat. It is the same name as the one on the shipping paper. The requirements for marking vary by package size and material being transported. When required, the shipper will put the following on the package:

- The name and address of shipper or consignee.
- The HazMat shipping name and ID number.
- The labels required.

It is a good idea to compare the shipping paper to the markings and labels. Always make sure that the shipper shows the correct basic description on the shipping paper, and verifies that the proper labels are shown on the packages. If you are not familiar with the material, ask the shipper to contact your office.

If HMR requires it, the shipper will put RQ, MARINE POLLUTANT, BIOHAZARD, HOT, or INHALATION-HAZARD on the package. Packages with liquid containers inside will also have package orientation markings with the arrows pointing in the correct upright direction. The labels used always reflect the hazard class of the product. If a package needs more than 1 label, the labels must be close together, near the proper shipping name.

9.3.8 – Recognizing Hazardous Materials

Learn to recognize shipments of HazMat. To find out if the shipment includes HazMat, look at the shipping paper. Does it have:

- An entry with a proper shipping name, hazard class, and ID number?
- A highlighted entry or one with an X or RQ in the HazMat column?

Other clues suggesting HazMat:

- What business is the shipper in? Paint dealer? Chemical supply? Scientific supply house? Pest control or agricultural supplier? Explosives, munitions, or fireworks dealer?
- Are there tanks with diamond labels or placards on the premises?
- What type of package is being shipped? Cylinders and drums are often used for HazMat shipments.
- Is a hazard class label, proper shipping name, or ID number on the package?
- Are there any handling precautions?

9.3.9 – Hazardous Waste Manifest

When transporting hazardous wastes, you must sign by hand and carry a Uniform Hazardous Waste Manifest. The name and Environmental Protection Agency (EPA) registration number of the shippers, carriers, and destination must appear on the manifest. Shippers must prepare, date, and sign by hand the manifest. Treat the manifest as a shipping paper when transporting the waste. Only give the waste shipment to another registered carrier or disposal/treatment facility. Each carrier transporting the shipment must sign by hand the manifest. After you deliver the shipment, keep your copy of the manifest. Each copy must have all needed signatures and dates, including those of the person to whom you delivered the waste.

9.3.10 – Placarding

Attach the appropriate placards to the vehicle before you drive it. You are only allowed to move an improperly placarded vehicle during an emergency, to protect life or property.

Placards must appear on both sides and ends of the vehicle. The front placard may be on the front of the tractor or trailer. Each placard must be:

- Easily seen from the direction it faces.
 - Placed so the words or numbers are level and read from left to right.
 - At least 3 inches away from any other markings.
 - Kept clear of attachments or devices such as ladders, doors, and tarpaulins.
 - Kept clean and undamaged so that the color, format, and message are easily seen.
 - Affixed to a background of contrasting color.
- NOTE:** the use of “Drive Safely” and other slogans is prohibited.

To decide which placards to use, you need to know:

- The hazard class of the materials.
- The amount of HazMat shipped.
- The total weight of all classes of HazMat in your vehicle.

9.3.11 – Placard Tables

There are 2 placard tables, Table 1 and 2. Table 1 materials must be placarded whenever any amount is transported. See Figure 9.7.

Except for bulk packaging, the hazard classes in Table 2 need placards only if the total amount transported is 1,001 pounds or more, including the package. Add the amounts from all shipping papers for the Table 2 products you have on board. See Figure 9.8.

You may use DANGEROUS placards instead of separate placards for each Table 2 hazard class when:

- You have 1,001 pounds or more, of 2 or more, Table 2 hazard classes, requiring different placards, and
- You have not loaded 2,205 pounds or more, of any Table 2 hazard class material, at any one place. (You must use the specific placard for this material.)

The DANGEROUS placard is an option, not a requirement. You can always placard for the materials.

- If the words INHALATION HAZARD are on the shipping paper or package, you must display POISON GAS or POISON INHALATION placards, in addition to any other placards needed by the product’s hazard class. The 1,000 pound exception does not apply to these materials.

- Materials with a secondary hazard of dangerous when wet must display the DANGEROUS WHEN WET placard in addition to any other placards needed by the product’s hazard class. The 1,000 pound exception to placarding does not apply to these materials.

Placards used to identify the primary or subsidiary hazard class of a material must have the hazard class or division number displayed in the lower corner of the placard. Permanently affixed subsidiary hazard placards without the hazard class number may be used as long as they stay within color specifications.

Placards may be displayed for HazMat even if not required so long as the placard identifies the hazard of the material being transported.

PLACARD TABLE 1 ANY AMOUNT	
<i>If your vehicle contains any amount of...</i>	<i>Placard as...</i>
1.1 Mass Explosives	Explosives 1.1
1.2 Project Hazards	Explosives 1.2
1.3 Mass Fire Hazards	Explosives 1.3
2.3 Poisonous/Toxic Gases	Poison Gas
4.3 Dangerous When Wet	Dangerous When Wet
5.2 (Organic Peroxide, Type B, liquid or solid, Temperature controlled)	Organic Peroxide
6.1 (Inhalation hazard zone A & B only)	Poison/toxic inhalation
7 (Radioactive Yellow III label only)	Radioactive

Figure 9.7

PLACARD TABLE 2 1,001 POUNDS OR MORE	
<i>Category of Material (Hazard class or division number and additional description, as appropriate)</i>	<i>Placard Name</i>
1.4 Minor Explosion	Explosives 1.4
1.5 Very Insensitive	Explosives 1.5
1.6 Extremely Insensitive	Explosives 1.6
2.1 Flammable Gases	Flammable Gas
2.2 Non-Flammable Gases	Non-Flammable Gas.
3 Flammable Liquids	Flammable
Combustible Liquid	Combustible*
4.1 Flammable Solids	Flammable Solid
4.2 Spontaneously Combustible	Spontaneously Combustible
5.1 Oxidizers	Oxidizer
5.2 (other than organic peroxide, Type B, liquid or solid, Temperature Controlled)	Organic Peroxide
6.1 (other than inhalation hazard zone A or B)	Poison
6.2 Infectious Substances	(None)
8 Corrosives	Corrosive
9 Miscellaneous HazMat	Class 9**
ORM-D	(None)
* FLAMMABLE may be used in place of a COMBUSTIBLE on a cargo tank or portable tank.	
** Class 9 Placard is not required for domestic transportation.	

Figure 9.8

Bulk packaging is a single container with a capacity greater than 119 gallons. A bulk package, and a vehicle transporting a bulk package, must be placarded, even if it only has the residue of a HazMat. Certain bulk packages only have to be placarded on the 2 opposite sides or display labels. All other bulk packages must be placarded on all 4 sides.



SUBSECTIONS 9.1, 9.2, AND 9.3

Test Your Knowledge

1. Shippers package in order to (fill in the blank) the material.
2. Drivers placard their vehicle to (fill in the blank) the risk.
3. What 3 things do you need to know to decide which placards (if any) you need?
4. A HazMat ID number must appear on the (fill in the blank) and on the (fill in the blank). The ID number must also appear on cargo tanks and other bulk packaging.
5. Where must you keep shipping papers describing HazMat?

These questions may be on your test. If you cannot answer them all, reread Subsections 9.1, 9.2, and 9.3.



9.4 – LOADING AND UNLOADING

Do all you can to protect containers of HazMat. Do not use any tools which might damage containers or other packaging during loading. Do not use hooks.

9.4.1 – General Loading Requirements

Before loading or unloading, set the parking brake. Make sure the vehicle will not move.

- Many products become more hazardous when exposed to heat. Load HazMat away from heat sources.
- Watch for signs of leaking or damaged containers. **LEAKS SPELL TROUBLE!** Do not transport leaking packages. Depending on the material, you, your truck, and others could be in danger. It is illegal to move a vehicle with leaking HazMat.

Containers of HazMat must be braced to prevent movement of packages during transportation.

No Smoking. When loading or unloading HazMat, keep fire away. Do not let people smoke nearby. Never smoke around:

- Class 1 (Explosives).
- Class 2.1 (Flammable Gas).
- Class 3 (Flammable Liquids).
- Class 4 (Flammable Solids).
- Class 5 (Oxidizers).

Secure Against Movement. Brace containers so they will not fall, slide, or bounce around during transportation. Be very careful when loading containers that have valves or other fittings. All HazMat packages must be secured during transportation.

After loading, do not open any package during your trip. Never transfer HazMat from 1 package to another while in transit. You may empty a cargo tank, but do not empty any other package while it is on the vehicle.

Cargo Heater Rules. There are special cargo heater rules for loading:

- Class 1 (Explosives).
- Class 2.1 (Flammable Gas).
- Class 3 (Flammable Liquids).

The rules usually forbid use of cargo heaters, including automatic cargo heater/air conditioner units. Unless you have read all the related rules, do not load the above products in a cargo space that has a heater.

Use Closed Cargo Space. You cannot have overhang or tailgate loads of:

- Class 1 (Explosives).
- Class 4 (Flammable Solids).
- Class 5 (Oxidizers).

You must load these HazMat into a closed cargo space unless all packages are:

- Fire and water-resistant.
- Covered with a fire and water-resistant tarp.

Precautions for Specific Hazards

Class 1 (Explosives) Materials. Turn your engine off before loading or unloading any explosives. Then check the cargo space. You must:

- Disable cargo heaters. Disconnect heater power sources and drain heater fuel tanks.
- Make sure there are no sharp points that might damage cargo. Look for bolts, screws, nails, broken side panels, and broken floorboards.
- Use a floor lining with Division 1.1, 1.2, or 1.3 Explosives. The floors must be tight and the liner must be either nonmetallic material or nonferrous metal. (Nonferrous metals are any metal that does not contain iron or iron alloys.)

Use extra care to protect explosives. Never use hooks or other metal tools. Never drop, throw, or roll packages. Protect explosive packages from other cargo that might cause damage.

Do not transfer a Division 1.1, 1.2, or 1.3 Explosive from 1 vehicle to another on a public roadway except in an emergency. If safety requires an emergency transfer, set out red warning reflectors, flags, or electric lanterns. You must warn others on the road.

Never transport damaged packages of explosives. Do not accept a package that shows any dampness or oily stain.

Do not transport Division 1.1 or 1.2 Explosives in vehicle combinations if:

- There is a marked or placarded cargo tank in the combination.
- The other vehicle in the combination contains:
 - Division 1.1 A (Initiating Explosives).
 - Packages of Class 7 (Radioactive) materials labeled “Yellow III.”
 - Division 2.3 (Poisonous Gas) or Division 6.1 (Poisonous) materials.
 - HazMat in a portable tank, on a DOT Spec 106A or 110A tank.

Class 4 (Flammable Solids) and Class 5 (Oxidizers) Materials. Class 4 materials are solids that react (including fire and explosion) to water, heat, and air, or even react spontaneously.

Class 4 and 5 materials must be completely enclosed in a vehicle or covered securely. Class 4 and 5 materials, which become unstable and dangerous when wet, must be kept dry while in transit and during loading and unloading. Materials that are subject to spontaneous combustion or heating must be in vehicles with sufficient ventilation.

Class 8 (Corrosive) Materials. If loading by hand, load breakable containers of corrosive liquid one by one. Keep them right side up. Do not drop or roll the containers. Load them onto an even floor surface. Stack carboys only if the lower tiers can bear the weight of the upper tiers safely.

Do not load nitric acid above any other product.

Load charged storage batteries so their liquid will not spill. Keep them right side up. Make sure other cargo will not fall against or short circuit them.

Never load corrosive liquids next to or above:

- Division 1.4 (Explosives C).
- Division 4.1 (Flammable Solids).
- Division 4.3 (Dangerous When Wet).
- Class 5 (Oxidizers).
- Division 2.3, Zone B (Poisonous Gases).

Never load corrosive liquids with:

- Division 1.1 or 1.2.
- Division 1.2 or 1.3.
- Division 1.5 (Blasting Agents).
- Division 2.3, Zone A (Poisonous Gases).
- Division 4.2 (Spontaneously Combustible Materials).
- Division 6.1, PGI, Zone A (Poison Liquids).

Class 2 (Compressed Gases) Materials, Including Cryogenic Liquids. If your vehicle does not have racks to hold cylinders, the cargo space floor must be flat. The cylinders must be:

- Held upright.
- In racks attached to the vehicle or in boxes that will keep them from turning over.

Cylinders may be loaded in a horizontal position (lying down) if it is designed so the relief valve is in the vapor space.

Division 2.3 (Poisonous Gas) or Division 6.1 (Poisonous) Materials. Never transport these materials in containers with interconnections. Never load a package labeled POISON or POISON INHALATION HAZARD in the driver's cab or sleeper or with food material for human or animal consumption. There are special rules for loading and unloading Class 2 materials in cargo tanks. You must have special training to do this.

Class 7 (Radioactive) Materials. Some packages of Class 7 (Radioactive) materials bear a number called the "transport index." The shipper labels these packages Radioactive II or Radioactive III, and prints the package's transport index on the label. Radiation surrounds each package, passing through all nearby packages. To deal with this problem, the number of packages you can load together is controlled. Their closeness to people, animals, and unexposed film is also controlled. The transport index tells the degree of control needed during transportation. The total transport index of all packages in a single vehicle must not exceed 50. Table A in this section (CFR, Title 49 §177.842) shows rules for each transport index. It shows how close you can load Class 7 (Radioactive) materials to people, animals, or film. For example, you cannot leave a package with a transport index of 1.1 within 2 feet of people or cargo space walls.

Mixed Loads. The rules require some products to be loaded separately. You cannot load them together in the same cargo space. Figure 9.9 lists some examples. The regulations (Segregation Table for Hazardous Materials) name other materials you must keep apart.

DO NOT LOAD TABLE	
<i>Do Not Load</i>	<i>In the Same Vehicle With</i>
Division 6.1 or 2.3 (POISON or poison inhalation hazard labeled material).	Animal or human food unless the poison package is over packed in an approved way. Foodstuffs are anything you swallow. However, mouthwash, toothpaste, and skin creams are not foodstuff.
Division 2.3 (Poisonous) gas Zone A or Division 6.1 (Poison) liquids, PGI, Zone A.	Division 1.1, 1.2, 1.3 Explosives, Division 5.1 (Oxidizers), Class 3 (Flammable Liquids), Class 8 (Corrosive Liquids), Division 5.2 (Organic Peroxides), Division 1.1, 1.2, 1.3 Explosives, Division 1.5 (Blasting Agents), Division 2.1 (Flammable Gases), Class 4 (Flammable Solids).
Charged storage batteries.	Division 1.1.
Class 1 (Detonating primers).	Any other explosives unless in authorized containers or packages.
Division 6.1 (Cyanides or cyanide mixtures).	Acids, corrosive materials, or other acidic materials which could release hydrocyanic acid. For Example: Cyanides, Inorganic, n.o.s. Silver Cyanide Sodium Cyanide.
Nitric acid (Class 8).	Other materials unless the nitric acid is not loaded above any other material.

Figure 9.9

////////////////////////////////////

SUBSECTION 9.4

Test Your Knowledge

6. Around which hazard classes must you never smoke?
7. Which 3 hazard classes should not be loaded into a trailer that has a heater/air conditioner unit?
8. Should the floor liner required for Division 1.1 or 1.2 materials be stainless steel?
9. At the shipper's dock, you are given a paper for 100 cartons of battery acid. You already have 100 pounds of dry Silver Cyanide on board. What precautions do you have to take?
10. Name a hazard class that uses transport indexes to determine the amount that can be loaded in a single vehicle.

These questions may be on your test. If you cannot answer them all, reread Subsection 9.4.

////////////////////////////////////

9.5 – BULK PACKAGING MARKING, LOADING, AND UNLOADING

The glossary at the end of this section gives the meaning of the word bulk. Cargo tanks are bulk packaging permanently attached to a vehicle. Cargo tanks remain on the vehicle when you load and unload them. Portable tanks are bulk packaging, which are not permanently attached to a vehicle. The product is loaded or unloaded while the portable tanks are off the vehicle. Portable tanks are then put on a vehicle for transportation. There are many types of cargo tanks in use. The most common cargo tanks are MC306 for liquids and MC331 for gases.

9.5.1 – Markings

You must display the ID number of the HazMat in portable tanks and cargo tanks and other bulk packaging (such as dump trucks). ID numbers are in Column 4 of the Hazardous Materials Table. The rules require black 100 mm (3.9 inch) numbers on orange panels, placards, or a white, diamond-shaped background if no placards are required. Specification cargo tanks must show retest date markings.

Portable tanks must show the lessee or owner's name. They must also display the shipping name of the contents on two opposing sides. The letters of the shipping name must be at least 2 inches tall on portable tanks with capacities of more than 1,000 gallons and 1-inch tall on portable tanks with capacities of less than 1,000 gallons. The ID number must appear on each side and each end of a portable tank or other bulk packaging that holds 1,000 gallons or more and on 2 opposing sides, if the portable tank holds less than 1,000 gallons. The ID numbers must still be visible when the portable tank is on the motor vehicle. If they are not visible, you must display the ID number on both sides and ends of the motor vehicle.

Intermediate bulk containers (IBCs) are bulk packaging, but are not required to have the owner's name or shipping name.

9.5.2 – Tank Loading

The person in charge of loading and unloading a cargo tank must be sure a qualified person is always watching. This person watching the loading or unloading must:

- Be alert.
- Have a clear view of the cargo tank.
- Be within 25 feet of the tank.

- Know the hazards of the materials involved.
- Know the procedures to follow in an emergency.
- Be authorized to move the cargo tank and able to do so.

There are special attendance rules for cargo tanks transporting propane and anhydrous ammonia.

Close all manholes and valves before moving a tank of HazMat, no matter how small the amount in the tank or how short the distance. Manholes and valves must be closed to prevent leaks. It is illegal to move a cargo tank with open valves or covers unless it is empty according to CFR, Title 49 §173.29.

9.5.3 – Flammable Liquids

Turn off your engine before loading or unloading any flammable liquids. Only run the engine if needed to operate a pump. Ground a cargo tank correctly before filling it through an open filling hole. Ground the tank before opening the filling hole, and maintain the ground until after closing the filling hole.

9.5.4 – Compressed Gas

Keep liquid discharge valves on a compressed gas tank closed except when loading and unloading. Unless your engine runs a pump for product transfer, turn it off when loading or unloading. If you use the engine, turn it off after product transfer, and before you unhook the hose. Unhook all loading/unloading connections before coupling, uncoupling, or moving a cargo tank. Always chock trailers and semi-trailers to prevent motion when uncoupled from the power unit.

SUBSECTION 9.5

Test Your Knowledge

11. What are cargo tanks?
12. How is a portable tank different from a cargo tank?
13. Your engine runs a pump used during delivery of compressed gas. Should you turn off the engine before or after unhooking hoses after delivery?

These questions may be on your test. If you cannot answer them all, reread Subsection 9.5.

9.6 – HAZARDOUS MATERIALS — DRIVING AND PARKING RULES

9.6.1 – Parking With Division 1.1, 1.2, or 1.3 Explosives

Never park with Division 1.1, 1.2, or 1.3 Explosives within 5 feet of the traveled part of the road. Except for short periods of time needed for vehicle operation necessities (for example, fueling), do not park within 300 feet of:

- A bridge, tunnel, or building.
- A place where people gather.
- An open fire.

If you must park to do your job, do so only briefly.

Do not park on private property unless the owner is aware of the danger. Someone must always watch the parked vehicle. You may let someone else watch it for you only if your vehicle is:

- On the shipper's property.
- On the carrier's property.
- On the consignee's property.

You are allowed to leave your vehicle unattended in a safe haven. A safe haven is an approved place for parking unattended vehicles loaded with explosives. Designation of authorized safe havens is usually made by local authorities.

9.6.2 – Parking a Placarded Vehicle Not Transporting Division 1.1, 1.2, or 1.3 Explosives

You may park a placarded vehicle (not laden with explosives) within 5 feet of the traveled part of the road only if your work requires it. Do so only briefly. Someone must always watch the vehicle when parked on a public roadway or shoulder. Do not uncouple a trailer and leave it with HazMat on a public street. Do not park within 300 feet of an open fire.

9.6.3 – Attending Placarded Parked Vehicles

The person attending a placarded vehicle must:

- Be in the vehicle, awake, and not in the sleeper berth, or within 100 feet of the vehicle, and have it within clear view.
- Be aware of hazards of the materials being transported.
- Know what to do in emergencies.
- Be able to move the vehicle, if needed.

9.6.4 – No Flares!

You might break down and have to use stopped vehicle signals. Use reflective triangles or red electric lights. Never use burning signals, such as flares or fuses, around a:

- Tank used for Class 3 (Flammable Liquids) or Division 2.1 (Flammable Gas) whether loaded or empty.
- Vehicle loaded with Division 1.1, 1.2, or 1.3 Explosives.

9.6.5 – Route Restrictions

Some states and counties require permits to transport HazMat or wastes. They may limit the routes you can use. Local rules about routes and permits change often. It is your job as driver to find out if you need permits or must use special routes. Make sure you have all needed papers before starting.

If you work for a carrier, ask your dispatcher about route restrictions or permits. If you are an independent trucker planning a new route, check with state agencies where you plan to travel. Some localities prohibit transportation of HazMat through tunnels, over bridges, or other roadways. Always check before you start.

Whenever placarded, avoid heavily populated areas, crowds, tunnels, narrow streets, and alleys. Take other routes, even if inconvenient, unless there is no other way. Never drive a placarded vehicle near open fires unless you can safely pass without stopping.

If transporting Division 1.1, 1.2, or 1.3 Explosives, you must have a written route plan and follow that plan. Carriers prepare the route plan in advance and give the driver a copy. You may plan the route yourself if you pick up the explosives at a location other than your employer's terminal. Write out the plan in advance. Keep a copy of it with you while transporting the explosives. Deliver shipments of explosives only to authorized persons or leave them in locked rooms designed for explosives storage.

A carrier must choose the safest route to transport placarded radioactive materials. After choosing the route, the carrier must tell the driver about the radioactive materials, and show the route plan.

Transporting Explosives in California

When transporting any amount of Division 1.1, 1.2, 1.3, or 1.6 Explosives or a combination of any of these explosives together with a Division 1.5 Explosives (blasting agent) as a delivery service or "for hire," you must use special routes, safe stopping places, safe parking places, and mandatory vehicle inspection locations prescribed by CHP. When transporting more than 1,000 pounds of these explosives in private carriage (other than as a delivery service) the same requirements apply.

Transporting Inhalation Hazards in California

Shipments of materials designated as POISON INHALATION HAZARD, TOXIC INHALATION HAZARD, or INHALATION HAZARD per CFR, Title 49 §172.203, when transported in bulk packaging (CFR, Title 49 §171.8), must also be transported using special routes, safe stopping places, and mandatory vehicle inspection locations prescribed by CHP for these materials.

Transporting Radioactive Materials in California

There are also specific routes prescribed by CHP for "Highway-Route Controlled Quantity (HRCQ)" and "Radioactive Materials (RAM)" shipments.

Drivers must have in their possession, a copy of the routes supplied by the carrier applicable to their shipment when transporting these materials. The routes, stopping places, and inspection locations are contained in CCR, Title 13 §§1150–1152.8 (Explosives), 1155–1157.20 (IH), and 1158–1159 (HRCQ). These requirements are also published by CHP.

Motor carriers may receive these publications, including revisions, by indicating their request on the APPLICATION FOR HAZARDOUS MATERIALS TRANSPORTATION LICENSE (CHP 361M) form or by contacting the DMV Commercial Vehicle Section, Routing Coordinator at (916) 327-3310.

California General Hazardous Materials Routing Requirement

The following general routing and parking restrictions (CVC §31303) apply to HazMat and waste shipments for which the display of vehicle placards and/or markings is required per CVC §27903 (**except shipments subject to, and in conformance with, special routing and related requirements**):

- Unless specifically restricted or prohibited (CVC §31304), use state or interstate highways that offer the least transit time whenever possible.
- Whenever practical, avoid congested highways, places where crowds are assembled, and residence districts (CVC §515).
- Deviation from designated routes is not excusable on the basis of operating convenience.
- Do not leave a loaded vehicle unattended or parked overnight in a residence district.

- Except for specifically restricted or prohibited highways, other highways may be used that provide necessary access for pick up or delivery consistent with safe vehicle operation.
- Highways that provide reasonable access to fuel, repairs, rest or food facilities that are designed and intended for commercial vehicle parking, when that access is safe and the facility is within 1/2 mile of the points of exit and/or entry to the designated route.
- Restricted or prohibited routes may only be used when no other lawful alternative exists. CHP also publishes a list of restricted or prohibited highways (CVC §31304). Copies of this list may be obtained by contacting the DMV Commercial Vehicle Section, Routing Coordinator at (916) 327-3310.

9.6.6 – No Smoking

Do not smoke within 25 feet of a placarded cargo tank used for Class 3 (flammable liquids) or Division 2.1 (gases). Also, do not smoke or carry a lighted cigarette, cigar, or pipe within 25 feet of any vehicle, which contains:

- Class 1 (Explosives).
- Class 3 (Flammable Liquids).
- Class 4.1 (Flammable Solids).
- Class 4.2 (Spontaneously Combustible).
- Class 5 (Oxidizers).

9.6.7 – Refuel With Engine Off

Turn off your engine before fueling a motor vehicle containing HazMat. Someone must always be at the nozzle, controlling fuel flow.

9.6.8 – 10 B:C Fire Extinguisher

The power unit of placarded vehicles must have a fire extinguisher with an Underwriters Laboratories (UL) rating of 10 B:C or more.

9.6.9 – Check Tires

Make sure your tires are properly inflated.

You must examine each tire on a motor vehicle at the beginning of each trip and each time the vehicle is parked.

The only acceptable way to check tire pressure is to use a tire pressure gauge.

Do not drive with a tire that is leaking or flat except to the nearest safe place to fix it. Remove any overheated tire. Place it a safe distance from your vehicle. Do not drive until you correct the cause of the overheating. Remember to follow the rules about parking and attending placarded vehicles. They apply even when checking, repairing, or replacing tires.

9.6.10 – Where to Keep Shipping Papers and Emergency Response Information

Do not accept a HazMat shipment without a properly prepared shipping paper. A shipping paper for HazMat must always be easily recognized. Other people must be able to find it quickly after an accident.

- Clearly distinguish HazMat shipping papers from others by tabbing them or keeping them on top of your stack of papers.
- When you are behind the wheel, keep shipping papers within your reach (with your seat belt on), or in a pouch on the driver's door. They must be easily seen by someone entering the cab.
- When not behind the wheel, leave shipping papers in the driver's door pouch or on the driver's seat.
- Emergency response information must be kept in the same location as the shipping paper.

Papers for Division 1.1, 1.2 or, 1.3 Explosives

A carrier must give each driver transporting Division 1.1, 1.2, or 1.3 Explosives a copy of FMCSR, Part 397. The carrier must also give written instructions on what to do if delayed or in an accident. The written instructions must include:

- The names and telephone numbers of people to contact (including carrier agents or shippers).
- The nature of the explosives transported.
- The precautions to take in emergencies such as fires, accidents, or leaks.

NOTE: Drivers must sign a receipt for these documents.

You must be familiar with, and have in your possession while driving:

- Shipping papers.
- Written emergency instructions.
- A written route plan.
- A copy of FMCSR, Part 397.

9.6.11 – Equipment for Chlorine

A driver transporting chlorine in cargo tanks must have an approved gas mask in the vehicle. The driver must also have an emergency kit for controlling leaks in dome cover plate fittings on the cargo tank.

9.6.12 – Stop Before Railroad Crossings

Stop before a railroad crossing if your vehicle:

- Is placarded.
- Carries any amount of chlorine.
- Has cargo tanks, whether loaded or empty, used for HazMat.

You must stop 15 to 50 feet before the nearest rail. Proceed only when you are sure no train is coming and you can clear the tracks without stopping. Do not shift gears while crossing the tracks.

9.7 – HAZARDOUS MATERIALS — EMERGENCIES

9.7.1 – Emergency Response Guidebook (ERG)

DOT has a guidebook for firefighters, police, and industry workers on how to protect themselves and the public from HazMat. The guide is indexed by the proper shipping name and HazMat ID number. Emergency personnel look for these things on the shipping paper. That is why it is vital that the proper shipping name, ID number, label, and placards are correct.

9.7.2 – Accidents/Incidents

As a professional driver, your job at the scene of an accident or incident is to:

- Keep people away from the scene.
- Limit the spread of material, only if you can safely do so.
- Communicate the danger of the HazMat to emergency response personnel.
- Provide emergency responders with the shipping papers and emergency response information.

Follow this checklist:

- Check to see that your driving partner is okay.
- Keep shipping papers with you.
- Keep people far away and upwind.
- Warn others of the danger.
- Call for help.
- Follow your employer's instructions.

9.7.3 – Fires

You might have to control minor truck fires on the road. However, unless you have the training and equipment to do so safely, do not fight HazMat fires. Dealing with HazMat fires requires special training and protective gear.

If you discover a fire, call for help! You may use the fire extinguisher to keep minor truck fires from spreading to cargo before firefighters arrive. Feel trailer doors to see if they are hot before opening them. If hot, you may have a cargo fire and should not open the doors. Opening doors lets air in and may make the fire flare up. Without air, many fires only smolder until firefighters arrive, doing less damage. If your cargo is already on fire, it is not safe to fight the fire. Keep the shipping papers with you to give to emergency personnel as soon as they arrive. Warn other people of the danger and keep them away.

If you discover a cargo leak, call for help! Identify the HazMat leaking using shipping papers, labels, or package location. Do not touch any leaking material—many people injure themselves by touching HazMat. Do not try to identify the material or find the source of a leak by smell. Toxic gases can destroy your sense of smell and injure or kill you, even if they do not smell. Never eat, drink, or smoke around a leak or spill.

If HazMat is spilling from your vehicle, call for help! Do not move your vehicle any more than safety requires. You may move off the road and away from places where people gather, if doing so serves safety. Only move your vehicle if you can do so without danger to yourself or others.

Never continue driving with HazMat leaking from your vehicle in order to find a phone booth, truck stop, help, or similar reason. Remember, the carrier pays for the cleanup of contaminated parking lots, roadways, and drainage ditches. The costs are enormous, so do not leave a lengthy trail of contamination. If HazMat is spilling from your vehicle:

- Park it.
- Secure the area.
- Stay there.
- Use your cell phone or CB to call for help.
- If your cell phone or CB does not work, send someone else for help.

When sending someone for help, give that person:

- A description of the emergency.
- Your exact location and direction of travel.
- Your name, the carrier's name, and the name of the community or city where your terminal is located.
- The proper shipping name, hazard class, and ID number of the HazMat, if you know them.

This is a lot for someone to remember. It is a good idea to write it all down for the person you send for help. The emergency response team must know these things to find you and to handle the emergency. They may have to travel miles to get to you. This information will help them to bring the right equipment the first time, without having to go back for it. (It may be quicker to take a picture of your shipping papers and emergency contact information with their cell phone.)

Never move your vehicle, if doing so will cause contamination or damage the vehicle. Keep upwind and away from roadside rest stops, truck stops, cafes, and businesses. Never try to repack leaking containers. Unless you have the training and equipment to repair leaks safely, do not try it. Call your dispatcher or supervisor for instructions and, if needed, emergency personnel.

9.7.4 – Responses to Specific Hazards

Class 1 (Explosives). If your vehicle has a breakdown or accident while carrying explosives, warn others of the danger. Keep bystanders away. Do not allow smoking or open fire near the vehicle. If there is a fire, warn everyone of the danger of explosion.

Remove all explosives before separating vehicles involved in an accident. Place the explosives at least 200 feet from vehicles and occupied buildings. Stay a safe distance away.

Class 2 (Compressed Gases). If compressed gas is leaking from your vehicle, warn others of the danger. Only permit those involved in removing the hazard or wreckage to get close. You must notify the shipper if compressed gas is involved in any accident.

Unless you are fueling machinery used in road construction or maintenance, do not transfer a flammable compressed gas from one tank to another on any public roadway.

Class 3 (Flammable Liquids). If you are transporting a flammable liquid and have an accident or your vehicle breaks down, prevent bystanders from gathering. Warn people of the danger. Keep them from smoking.

Never transport a leaking cargo tank farther than needed to reach a safe place. Get off the roadway if you can do so safely. Do not transfer flammable liquid from one vehicle to another on a public roadway except in an emergency.

Class 4 (Flammable Solids) and Class 5 (Oxidizing Materials). If a flammable solid or oxidizing material spills, warn others of the fire hazard. Do not open smoldering packages of flammable solids. Remove them from the vehicle if you can safely do so. Also, remove unbroken packages if it will decrease the fire hazard.

Class 6 (Poisonous Materials and Infectious Substances). It is your job to protect yourself, other people, and property from harm. Remember that many products classed as poison are also flammable. If you think a Division 2.3 (Poison Gases) or Division 6.1 (Poison Materials) might be flammable, take the added precautions needed for flammable liquids or gases. Do not allow smoking, open flame, or welding near the vehicle. Warn others of the hazards of fire, inhaling vapors, or coming in contact with the poison.

A vehicle involved in a leak of Division 2.3 (Poison Gases) or Division 6.1 (Poisons) must be checked for stray poison before being used again.

If a Division 6.2 (Infectious Substances) package is damaged in handling or transportation, you should immediately contact your supervisor. Packages that appear to be damaged or show signs of leakage should not be accepted.

Class 7 (Radioactive Materials). If radioactive material is involved in a leak or broken package, tell your dispatcher or supervisor as soon as possible. If there is a spill, or an internal container might be damaged, do not touch or inhale the material. Do not use the vehicle until it is cleaned and checked with a survey meter.

Class 8 (Corrosive Materials). If corrosives spill or leak during transportation, be careful to avoid further damage or injury when handling the containers. Parts of the vehicle exposed to a corrosive liquid must be thoroughly washed with water. After unloading, wash out the interior as soon as possible before reloading.

If continuing to transport a leaking tank would be unsafe, get off the road. If safe to do so, contain any liquid leaking from the vehicle. Keep bystanders away from the liquid and its fumes. Do everything possible to prevent injury to you and others.

9.7.5 – Required Notification

The National Response Center helps coordinate emergency response to chemical hazards. It is a resource to police and firefighters. It maintains a 24-hour toll-free phone line listed below. You or your employer must phone when any of the following occur as a direct result of a HazMat incident:

- A person is killed.
- An injured person requires hospitalization.
- Estimated property damage exceeds \$50,000.
- The general public is evacuated for more than 1 hour.
- One or more major transportation arteries or facilities are closed for 1 hour or more.
- Fire, breakage, spillage, or suspected radioactive contamination occurs.
- Fire, breakage, spillage, or suspected contamination occurs involving shipment of infectious substances (bacteria or toxins).
- The release of a marine pollutant in a quantity greater than 119 gallons for a liquid or 882 pounds for a solid; or a situation exists (for example, continuing danger to life exists at the scene of an incident) that, in the judgment of the carrier, should be reported to:

National Response Center
1-800-424-8802

Persons telephoning the National Response Center should be ready to give:

- Their name.
- Name and address of the carrier they work for.
- Phone number where they can be reached.
- Date, time, and location of incident.
- The extent of injuries, if any.
- Classification, name, and quantity of HazMat involved, if such information is available.
- Type of incident, nature of HazMat involvement, and whether a continuing danger to life exists at the scene.

If a reportable quantity of hazardous substance was involved, the name of the shipper and quantity of the hazardous substance discharged.

Be prepared to give your employer the required information as well. Carriers must make detailed written reports within 30 days of an incident to:

CHEMTREC
1-800-424-9300

The Chemical Transportation Emergency Center (CHEMTREC) in Washington, DC, also has a 24-hour toll-free phone line. CHEMTREC was created to provide emergency personnel with technical information about the physical properties of HazMat. The National Response Center and CHEMTREC are in close communication. If you call either one, they will tell the other about the problem, when appropriate.

Do not leave radioactive Yellow II or Yellow III labeled packages near people, animals, or film longer than shown in Figure 9.10

RADIOACTIVE SEPARATION TABLE A						
Total Transport Index	Minimum Distance in Feet to Nearest Undeveloped Film					To People or Cargo Compartment Partitions
	0-2 Hrs.	2-4 Hrs.	4-8 Hrs.	8-12 Hrs.	Over 12 Hrs.	
None	0	0	0	0	0	0
0.1 to 1.0	1	2	3	4	5	1
1.1 to 5.0	3	4	6	8	11	2
5.1 to 10.0	4	6	9	11	15	3
10.1 to 20.0	5	8	12	16	22	4
20.1 to 30.0	7	10	15	20	29	5
30.1 to 40.0	8	11	17	22	33	6
40.1 to 50.0	9	12	19	24	36	

Figure 9.10

California Immediate Spill Reporting

Spills of HazMat on California highways must be reported immediately to the CHP office or police department having traffic control jurisdiction (CVC §23112.5).

Classes of Hazardous Materials

HazMat is categorized into 9 major hazard classes and additional categories for consumer commodities and combustible liquids. The classes of HazMat are listed in Figure 9.11.

HAZARD CLASS DEFINITIONS TABLE B		
Class	Class Name	Example
1	Explosives	Ammunition, Dynamite, Fireworks
2	Gases	Propane, Oxygen, Helium
3	Flammable	Gasoline, Acetone
4	Flammable Solids	Matches, Fuses
5	Oxidizers	Ammonium Nitrate, Hydrogen Peroxide
6	Poisons	Pesticides, Arsenic
7	Radioactive	Uranium, Plutonium
8	Corrosives	Hydrochloric Acid, Battery Fluid
9	Miscellaneous HazMat	Formaldehyde, Asbestos
None	ORM-D (Other Regulated Material-Domestic)	Hair Spray, Charcoal
None	Combustible Liquids	Fuel Oils, Lighter Fluid

Figure 9.11

SUBSECTIONS 9.6 AND 9.7

Test Your Knowledge

14. If your placarded trailer has dual tires, how often should you check the tires?
 15. What is a safe haven?
 16. How close to the traveled part of the roadway can you park with Division 1.2 or 1.3 materials?
 17. How close can you park to a bridge, tunnel, or building with the same load?
 18. What type of fire extinguisher must placarded vehicles carry?
 19. You are hauling 100 pounds of Division 4.3 (DANGEROUS WHEN WET) materials. Do you need to stop before a railroad-highway crossing?
 20. At a rest area you discover your HazMat shipment is slowly leaking from the vehicle. There is no phone around. What should you do?
 21. What is the *Emergency Response Guide* (ERG)?
- These questions may be on your test. If you cannot answer them all, reread Subsections 9.6 and 9.7.

9.8 – HAZARDOUS MATERIALS — GLOSSARY

This glossary presents definitions of certain terms used in this section. A complete glossary of terms can be found in the federal HMR (CFR, Title 49 §171.8). You should have an up-to-date copy of these rules for your reference.

NOTE: You will not be tested on this glossary.

9.8.1 – CFR, Title 49 §171.8 Definitions and Abbreviations

Bulk packaging—Packaging, other than a vessel or barge, including a transport vehicle or freight container, in which HazMat are loaded with no intermediate form of containment and which has:

22. A maximum capacity greater than 119 gallons (450 L) as a receptacle for a liquid.
23. A maximum net mass greater than 882 pounds (400 kg) and maximum capacity greater than 119 gallons (450 L) as a receptacle for a solid.

OR

24. A water capacity greater than 1,000 pounds (454 kg) as a receptacle for a gas as defined in CFR, Title 49 §173.115.

Cargo tank—A bulk packaging which is:

1. A tank intended primarily for the carriage of liquids or gases and includes, appurtenances, reinforcements, fittings, and closures (for “tank” definition, see CFR, Title 49 §§178.3451(c), 178.3371, or 178.3381, as applicable).
2. Permanently attached to or forms a part of a motor vehicle, or not permanently attached to a motor vehicle but which, by reason of its size, construction, or attachment to a motor vehicle, is loaded or unloaded without being removed from the motor vehicle.
3. Not fabricated under a specification for cylinders, portable tanks, tank cars, or multi-unit tank car tanks.

Carrier—A person who transports passengers or property in commerce by rail, car, aircraft, motor vehicle, or vessel.

Consignee—The business or person to whom a shipment is delivered.

Division—A subdivision of a hazard class.

EPA—U.S. Environmental Protection Agency.

FMCSR—Federal Motor Carrier Safety Regulations.

Freight container—A reusable container having a volume of 64 cubic feet or more, designed and constructed to permit being lifted with its contents intact and intended primarily for containment of packages (in unit form) during transportation.

Fuel tank—A tank, other than a cargo tank, used to transport flammable or combustible liquid or compressed gas for the purpose of supplying fuel for propulsion of the transport vehicle to which it is attached, or for the operation of other equipment on the transport vehicle.

Gross weight or mass—The weight of the packaging plus the weight of its contents.

Hazard class—The category of hazard assigned to a HazMat under the definition criteria of CFR, Title 49, Part 173 and the provisions of the CFR, Title 49 §172.101 table. A material may meet the defining criteria for more than one hazard class but is assigned to only one hazard class.

Hazardous Materials (HazMat)—A substance or material which has been determined by the U.S. Secretary of Transportation to be capable of posing an unreasonable risk to health, safety, and property when transported in commerce, and which has been so designated. The term includes hazardous substances, hazardous wastes, marine pollutants, elevated temperature materials, and materials designated as hazardous in the Hazardous Materials Table of CFR, Title 49 §172.101, and materials that meet the definition criteria for hazard classes and divisions in CFR, Title 49, Part 173, Subchapter C.

Hazardous substance—A material, including its mixtures and solutions, that:

1. Is listed in Appendix A to CFR, Title 49 §§173 and 172.101.
2. Is in a quantity, in one package, which equals or exceeds the reportable quantity (RQ) listed in Appendix A to CFR, Title 49, Part 173 and §172.101.

AND

3. When in a mixture or solution for:
 - Radionuclides, conforms to paragraph 7 of Appendix A to CFR, Title 49, Part 173 and §172.101.
 - Other than radionuclides, is in a concentration by weight which equals or exceeds the concentration corresponding to the RQ of the material, as shown in Figure 9.12.

HAZARDOUS SUBSTANCE CONCENTRATIONS		
<i>RQ Pounds (Kilograms)</i>	<i>Concentration by Weight</i>	
	<i>Percent</i>	<i>PPM</i>
5,000 (2,270)	10	100,000
1,000 (454)	2	20,000
100 (45.4)	.2	2,000
10 (4.54)	.02	200
1 (0.454)	.002	20

Figure 9.12

This definition does not apply to petroleum products that are lubricants or fuels (see CFR, Title 40 §300.6).

Hazardous waste—For the purposes of this chapter, means any material that is subject to the Hazardous Waste Manifest Requirements of the EPA specified in CFR, Title 40 §262.

Intermediate bulk container (IBC)—A rigid or flexible portable packaging, other than a cylinder or portable tank, which is designed for mechanical handling. Standards for IBCs manufactured in the U.S. are set forth in CFR, Title 49 §178, Subparts N and O.

Limited quantity—The maximum amount of a HazMat for which there may be specific labeling or packaging exceptions.

Marking—The descriptive name, ID number, instructions, cautions, weight, specification, United Nations (UN) marks, or combinations thereof, required on outer packaging of HazMat.

Mixture—A material composed of more than 1 chemical compound or element.

Name of contents—The proper shipping name as specified in CFR, Title 49 §172.101.

Nonbulk packaging—A packaging, which has:

1. A maximum capacity of 119 gallons (450 L) or less as a receptacle for a liquid.
 2. A maximum net mass less than 882 pounds (400 kg) or less and a maximum capacity of 119 gallons (450 L) or less as a receptacle for a solid.
- OR
3. A water capacity greater than 1,000 pounds (454 kg) or less as a receptacle for a gas as defined in CFR, Title 49 §173.115.
 4. Regardless of the definition of bulk packaging, a maximum net mass of 400 kg (882 pounds) or less for a bag or box conforming to the applicable requirements for specification packaging, including the maximum net mass limitations, provided in CFR, Title 49, Part 178, Subpart L.

N.O.S.—Not otherwise specified.

Outage or ullage—The amount by which a packaging falls short of being liquid full, usually expressed in percent by volume. The amount of outage required for liquids in cargo tank depends on how much the material will expand with temperature change during transit. Different materials expand at different rates. Enough outage must be allowed so that the tank will not be full at 130 degrees Fahrenheit.

PHMSA—Pipeline and Hazardous Materials Safety Administration, U.S. Department of Transportation, Washington, DC 20590.

Portable tank—Bulk packaging (except a cylinder having a water capacity of 1,000 pounds or less) designed primarily to be loaded onto, on, or temporarily attached to a transport vehicle or ship, and equipped with skids, mountings, or accessories to facilitate handling the tank by mechanical means. It does not include a cargo tank, tank car, multiunit tank car tank, or trailer carrying 3AX, 3AAX, or 3T cylinders.

Proper shipping name—The name of the HazMat shown in Roman print (not italics) in CFR, Title 49 §172.101.

P.s.i. or psi—Pounds per square inch.

P.s.i.a. or psia—Pounds per square inch absolute.

Reportable quantity (RQ)—The quantity specified in Column 2 of Appendix A to CFR, Title 49 §172.101 for any material identified in Column 1 of Appendix A.

Shipper's certification—A statement on a shipping paper, signed by the shipper, saying they prepared the shipment properly according to law. For example:

“This is to certify that the above named materials are properly classified, described, packaged, marked, and labeled, and are in proper condition for transportation according to the applicable regulations or the Department of Transportation.”

OR

“I hereby declare that the contents of this consignment are fully and accurately described above by the proper shipping name and are classified, packaged, marked, and labeled/placarded, and are in all respects in proper condition for transport by (insert mode of transportation, such as rail, aircraft motor vehicle, or vessel) according to applicable international and national government regulations.”

Shipping paper—A shipping order, bill of lading, manifest, or other shipping document serving a similar purpose prepared in accordance with CFR, Title 49 §172, Subpart C.

Technical name—A recognized chemical name or microbiological name currently used in scientific and technical handbooks, journals, and texts.

Transport vehicle—A cargo-carrying vehicle such as an automobile, van, tractor, truck, semi-trailer, tank car, or rail car used for transportation of cargo by any mode. Each cargo-carrying body (trailer, rail car, etc.) is a separate transport vehicle.

UN standard packaging—Packaging specifications conforming to standards in UN recommendations.

UN—United Nations.

SECTION 10: SCHOOL BUSES

THIS SECTION COVERS

- 10.1 – Danger Zones and Use of Mirrors
- 10.2 – Loading and Unloading
- 10.3 – Emergency Exit and Evacuation
- 10.4 – Railroad-Highway Grade Crossings
- 10.5 – Student Management
- 10.6 – Anti-lock Braking Systems
- 10.7 – Special Safety Considerations

You should be thoroughly familiar with California and your local school district laws and regulations.

A CLP holder with a “P” and/or an “S” endorsement is prohibited from operating a CMV with passengers, other than federal/state auditors and inspectors, test examiners, other trainees, and the accompanying CDL holder (CFR, Title 49 §383.25).

NOTE: As of July 1, 2018, it is required that a passenger in a bus equipped with seat belts to be properly restrained by a safety belt, except as specified. Parents, legal guardians, or chartering parties are prohibited from transporting on a bus, or permitting to be transported on a bus, a child who is at least 8 years old but under 16 years old, unless they are properly restrained by a safety belt.

10.1 – DANGER ZONES AND USE OF MIRRORS

10.1.1 – Danger Zones

The danger zone is the area on all sides of the bus where children are in the most danger of being hit, either by another vehicle or their own bus. The danger zones may extend as much as 30 feet from the front bumper (with the first 12 feet being the most dangerous), 12 feet from the left and right sides, and 12 feet behind the rear bumper of the school bus. In addition, the area to the left of the bus is always considered dangerous because of passing cars. Figure 10.1 illustrates these danger zones.

10.1.2 – Correct Mirror Adjustment

Proper adjustment and use of all mirrors is vital to safe operation of the school bus in order to observe the danger zone around the bus and look for students, traffic, and other objects in this area. You should always check each mirror before operating the school bus to obtain maximum viewing area. If necessary, have the mirrors adjusted.

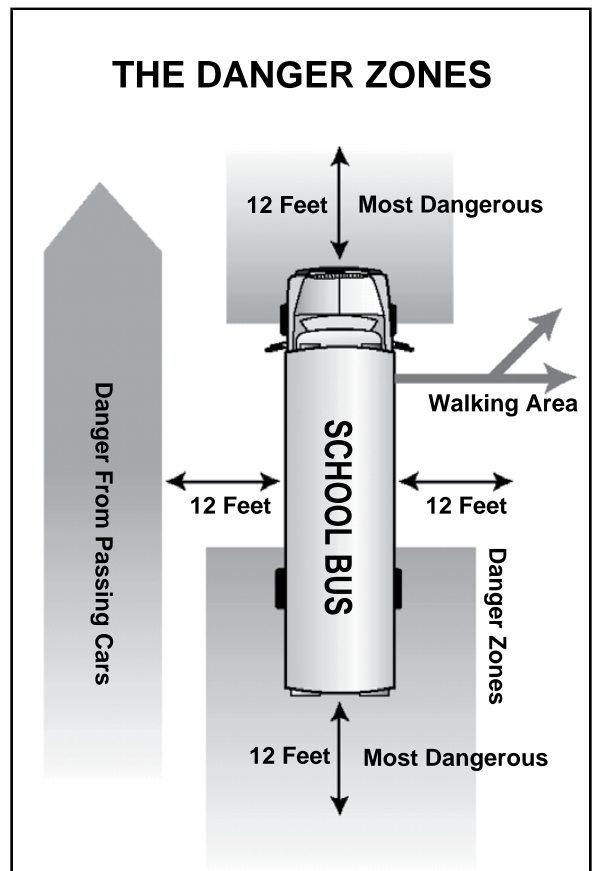

Figure 10.1

10.1.3 – Outside Left and Right Side Flat Mirrors

These mirrors are mounted at the left and right front corners of the bus at the side or front of the windshield. They are used to monitor traffic, check clearances, and check for students on the sides and to the rear of the bus. There is a blind spot immediately below and in front of each mirror and directly in back of the rear bumper. The blind spot behind the bus extends 50 to 150 feet and could extend up to 400 feet depending on the length and width of the bus.

Ensure that the mirrors are properly adjusted so you can see:

- 200 feet or 4 bus lengths behind the bus.
- Along the sides of the bus.
- The rear tires touching the ground.

Figure 10.2 shows how both the outside left and right side flat mirrors should be adjusted.

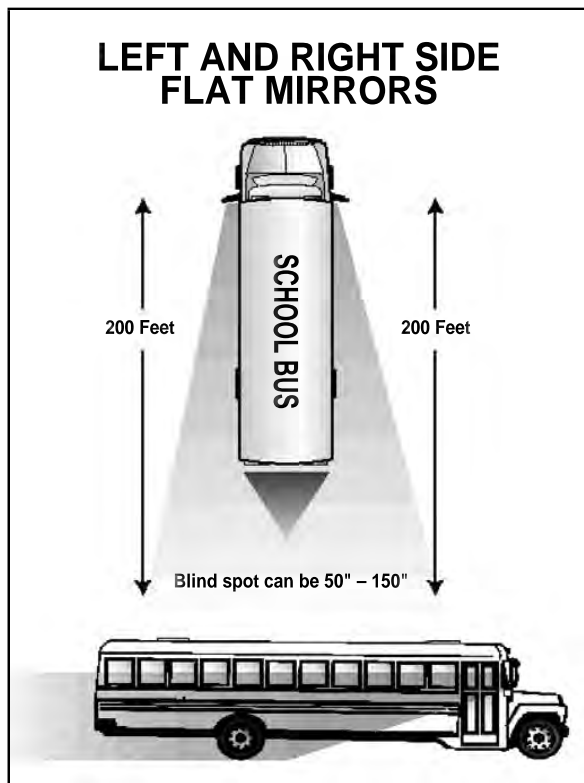

Figure 10.2

10.1.4 – Outside Left and Right Side Convex Mirrors

The convex mirrors are located below the outside flat mirrors. They are used to monitor the left and right sides at a wide angle. They provide a view of traffic, clearances, and students at the side of the bus. These mirrors present a view of people and objects that does not accurately reflect their size and distance from the bus.

You should position these mirrors to see:

- The entire side of the bus up to the mirror mounts.
- The front of the rear tires touching the ground.
- At least 1 traffic lane on either side of the bus.

Figure 10.3 shows how both the outside left and right side convex mirrors should be adjusted.

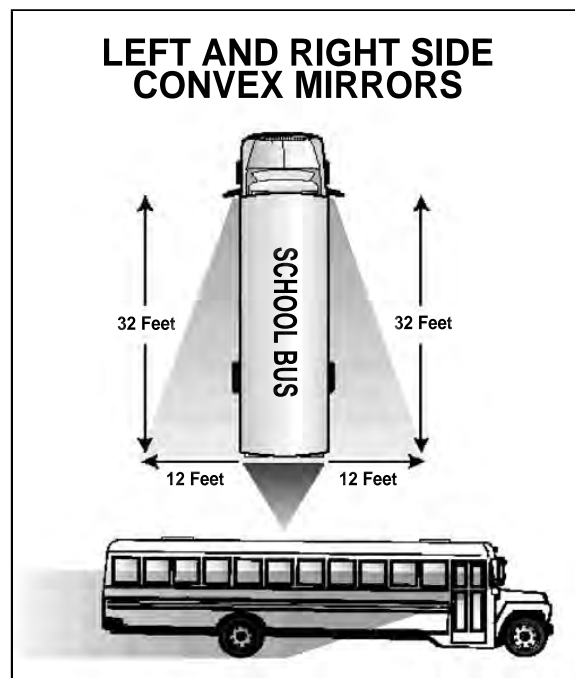

Figure 10.3

10.1.5 – Outside Left and Right Side Crossview Mirrors

These mirrors are mounted on both the left and right front corners of the bus. They are used to see the front bumper “danger zone” area directly in front of the bus that is not visible by direct vision, and the “danger zone” area to the left and right side of the bus, including the service door and front wheel area. The mirror presents a view of people and objects that does not accurately reflect their size and distance from the bus. The driver must ensure that these mirrors are properly adjusted. Every school bus shall be

equipped with a crossview mirror mounted on the front exterior of the bus to provide the seated driver with a clear view of the area directly in front of the bus (CCR, Title 13 §1258).

Ensure that the mirrors are properly adjusted so you can see:

- The entire area in front of the bus from the front bumper at ground level to a point where direct vision is possible. Direct and mirror view vision should overlap.
- The right and left front tires touching the ground.
- The area from the front of the bus to the service door.
- These mirrors, along with the convex and flat mirrors, should be viewed in a logical sequence to ensure that a child or object is not in any of the danger zones.

Figure 10.4 illustrates how the left and right side crossview mirrors should be adjusted.

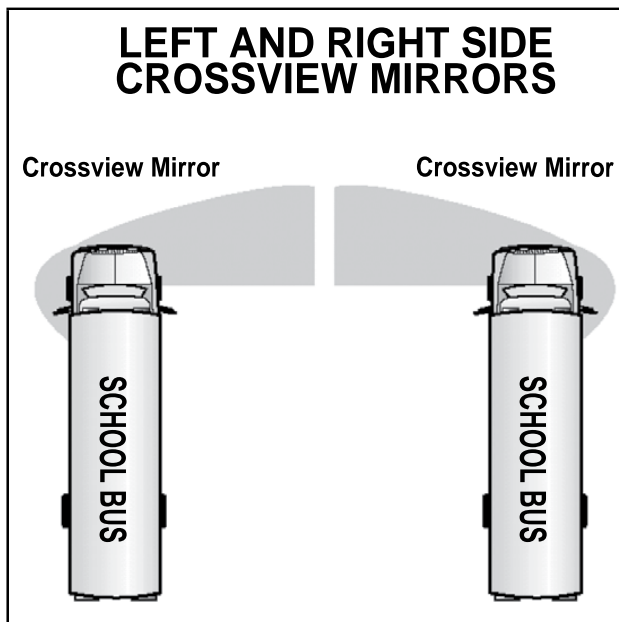

Figure 10.4

10.1.6 – Overhead Inside Rearview Mirror

This mirror is mounted directly above the windshield on the driver's side area of the bus. This mirror is used to monitor passenger activity inside the bus. It may provide limited visibility directly behind the bus if the bus is equipped with a glass-bottom rear emergency door. There is a blind spot area directly behind the driver's seat, as well as a large blind spot area that begins at the rear bumper and could extend up to 400 feet or more behind the bus. You must use the exterior side mirrors to monitor traffic that approaches and enters this area.

You should position the mirror to see:

- The top of the rear window in the top of the mirror.
- All of the students, including the heads of the students right behind you.

10.2 – LOADING AND UNLOADING

More students are killed while getting on or off a school bus each year than are killed as passengers inside of a school bus. As a result, knowing what to do before, during, and after loading or unloading students is critical. This section will give you specific procedures to help you avoid unsafe conditions that could result in injuries and fatalities during and after loading and unloading students.

The information in this section is intended to provide a broad overview, but is not a definitive set of actions. It is imperative that you learn and obey California's laws and regulations governing loading/unloading operations.

10.2.1 – Approaching the Stop

Each school district establishes official routes and school bus stops. All stops should be approved by the school district prior to making the stop. You should never change the location of a bus stop without written approval from the appropriate school district official.

You must use extreme caution when approaching a school bus stop. You are in a very demanding situation when entering these areas. It is critical that you understand and follow all state and local laws and regulations regarding approaching a school bus stop. This would involve the proper use of mirrors, alternating flashing lights, and when equipped, the moveable stop signal arm, and crossing control arm.

When approaching the stop, you should:

- Approach cautiously at a slow rate of speed.
- Look for pedestrians, traffic, or other objects before, during, and after coming to a stop.
- Continuously check all mirrors.
- If the school bus is so equipped, activate alternating flashing amber warning lights at least 200 feet or approximately 5–10 seconds before the school bus stop or in accordance with state law.
- Turn on the right turn signal indicator about 100–300 feet or approximately 3–5 seconds before pulling over.
- Continuously check mirrors to monitor the danger zones for students, traffic, and other objects.
- Move as far as possible to the right on the traveled portion of the roadway.

When stopping, you should:

- Bring the school bus to a full stop with the front bumper at least 10 feet away from students at the designated stop. This forces the students to walk to the bus so you have a better view of their movements.
- Place the transmission in Park or, if there is no Park shift point, in Neutral, and set the parking brake at each stop.
- Activate the alternating red lights when traffic is a safe distance from the school bus and ensure the stop arm is extended.
- Make a final check to see that all traffic has stopped before completely opening the door and signaling students to approach.

10.2.2 – Loading Procedures

Perform a safe stop as described in Section 10.

- Students should wait in a designated location for the school bus, facing the bus as it approaches.
- Students should board the bus only when signaled by the driver.
- Monitor all mirrors continuously.
- Count the number of students at the bus stop and be sure all board the bus. If possible, know the names of the students at each stop. If there is a student missing, ask the other students where the student is.
- Have the students board the school bus slowly, in single file, and use the handrail. The dome light should be on while loading in the dark.
- Wait until students are seated and facing forward before moving the bus.
- Check all mirrors. Make certain no one is running to catch the bus.
- If you cannot account for a student, secure the bus, take the key, and check around and underneath the bus. When all students are accounted for, prepare to leave by:
 - Closing the door.
 - Engaging the transmission.
 - Releasing the parking brake.
 - Turning off the alternating flashing red lights.
 - Turning on the left turn signal.
 - Checking all the mirrors again.
 - Allowing congested traffic to disperse.
- When it is safe, move the bus, enter the traffic flow, and continue the route.

The loading procedure is essentially the same wherever you load students, but there are slight differences. When students are loading at the school campus, you should:

- Turn off the ignition switch.
- Remove the key if leaving the driver's compartment.
- Position yourself to supervise loading.

10.2.3 – Unloading Procedures on the Route

Perform a safe stop at designated unloading areas as described in Section 10.

- Have the students remain seated until told to exit.
- Check all mirrors.
- Count the number of students while unloading to confirm the location of all students before pulling away from the stop.
- Tell students to exit the bus and walk at least 10 feet away from the side of the bus to a position where the driver can plainly see all students.
- Check all mirrors again. Make sure no students are around or returning to the bus.
- If you cannot account for a student, secure the bus, take the key, and check around and underneath the bus.
- When all students are accounted for, prepare to leave by:
 - Closing the door.
 - Engaging the transmission.
 - Releasing the parking brake.
 - Turning off the alternating flashing red lights.
 - Turning on the left turn signal.
 - Checking all the mirrors again.
 - Allowing congested traffic to disperse.
- When it is safe, move the bus, enter the traffic flow, and continue the route.

NOTE: If you miss a student’s unloading stop, do not back up. Be sure to follow local procedures.

Additional Procedures for Students Who Must Cross the Roadway

When a school bus is stopped on a highway or private road for the purpose of loading or unloading students, at a location where traffic is not controlled by a traffic officer or official traffic control signal, the school bus driver shall do all of the following:

- Escort all students in prekindergarten, kindergarten, or any grades 1 through 8, who need to cross the highway or private road where the school bus stopped. The driver shall use an approved, hand-held “STOP” sign while escorting all students.
- Require all students who cross the highway or private road where the school bus stopped to walk in front of the bus as they cross.
- Ensure that all students who cross the highway or private road where the school bus stopped have crossed safely, and that all other students and pedestrians are at a safe distance from the school bus before setting the school bus in motion.

NOTE: The school bus driver should enforce any state or local regulations or recommendations concerning student actions outside the school bus.

10.2.4 – Unloading Procedures at School

State and local laws and regulations regarding unloading students at schools, particularly in situations where activities take place in the school parking lot or other location off the traveled roadway, are often different than unloading along the school bus route. It is important that the school bus driver understands and obeys state and local laws and regulations. The following procedures are meant to be general guidelines.

When unloading at the school, you should follow these procedures:

- Perform a safe stop at designated unloading areas as described in Section 10.
- Secure the bus by:
 - Turning off the ignition switch.
 - Removing the key if leaving the driver’s compartment.

- Have the students remain seated until told to exit.
- Position yourself to supervise unloading.
- Escort all students in prekindergarten, kindergarten, or any of grades 1 through 8, inclusive, who need to cross the highway or private road where the school bus stopped. The driver shall use an approved, hand-held “STOP” sign while escorting all students.
- Have the students exit in orderly fashion.
- Observe the students as they step from the bus to see that they all move promptly away from the unloading area.
- Walk through the bus to check for hiding/sleeping students and items left by students.
- Check all mirrors. Make certain no students are returning to the bus.
- If the bus is secure and you cannot account for a student outside the bus, take the key, and check around and underneath the bus.
- When all students are accounted for, prepare to leave by:
 - Closing the door.
 - Fastening the safety belt.
 - Starting the engine.
 - Engaging the transmission.
 - Releasing the parking brake.
 - Turning off the alternating flashing red lights.
 - Turning on the left turn signal.
 - Checking all the mirrors again.
 - Allowing congested traffic to disperse.
- When it is safe, pull away from the unloading area.

10.2.5 – Special Dangers of Loading and Unloading

Dropped or Forgotten Objects. Always focus on students as they approach the bus and watch for any who disappear from sight.

Students may drop an object near the bus during loading and unloading. Stopping to pick up the object or returning to pick up the object may cause the student to disappear from the driver’s sight at a very dangerous moment.

Students should be told to leave any dropped object and move to a point of safety out of the danger zones and attempt to get the driver’s attention to retrieve the object.

Handrail Hang-Ups. Students have been injured or killed when clothing, accessories, or even parts of their body are caught in the handrail or door as they exited the bus. You should closely observe all students exiting the bus to confirm that they are in a safe location prior to moving the bus.

10.2.6 – Post-Trip Inspection

When your route or school activity trip is finished, you should conduct a post-trip inspection of the bus.

You should walk through the bus and around the bus to look for the following:

- Articles left on the bus.
- Sleeping students.
- Open windows and doors.
- Mechanical/operational problems with the bus, with special attention to items that are unique to school buses—mirror systems, flashing warning lamps, and stop signal arms.
- Damage or vandalism.

Any problems or special situations should be reported immediately to your supervisor or school authorities.

10.3 – EMERGENCY EXIT AND EVACUATION

An emergency situation can happen to anyone, anytime, anywhere. It could be an accident, stalled school bus on a railroad-highway crossing or in a high-speed intersection, electrical fire in the engine compartment, or medical emergency to a student on the school bus, etc. Knowing what to do in an emergency—before, during, and after an evacuation—can mean the difference between life and death.

10.3.1 – Planning for Emergencies

Determine the Need to Evacuate the Bus. The first and most important consideration is for you to recognize the hazard. If time permits, school bus drivers should contact their dispatcher to explain the situation before making a decision to evacuate the school bus.

As a general rule, student safety and control is best maintained by keeping students on the bus during an emergency and/or impending crisis situation, if it does not expose them to unnecessary risk or injury. Remember, the decision to evacuate the bus must be a timely one.

A decision to evacuate should include consideration of the following conditions:

- Is there a fire or danger of fire?
- Is there a smell of raw or leaking fuel?
- Is there a chance the bus could be hit by other vehicles?
- Is the bus in the path of a sighted tornado or rising waters?
- Are there downed power lines?
- Would removing students expose them to speeding traffic, severe weather, or a dangerous environment such as downed power lines?
- Would moving students complicate injuries such as neck and back injuries and fractures?
- Is there a hazardous spill involved? Sometimes, it may be safer to remain on the bus and not come in contact with the material.

Mandatory Evacuations. The driver must evacuate the bus when:

- The bus is on fire or there is a threat of a fire.
- The bus is stalled on or adjacent to a railroad-highway crossing.
- The position of the bus may change and increase the danger.
- There is an imminent danger of an accident.
- There is a need to quickly evacuate because of a HazMat spill.

10.3.2 – Evacuation Procedures

Be Prepared and Plan Ahead. When possible, assign 2 older, responsible student assistants to each emergency exit. Teach them how to assist the other students off the bus. Assign another student assistant to lead the students to a “safe place” after evacuation. However, you must recognize there may not be older, responsible students on the bus at the time of the emergency. Therefore, emergency evacuation procedures **must** be explained to all students. This includes knowing how to operate the various emergency exits and the importance of listening to and following all instructions given by you.

Some tips to determine a safe place:

- A safe place will be at least 100 feet off the road in the direction of oncoming traffic. This will keep the students from being hit by debris if another vehicle collides with the bus.
- Lead students upwind (into the wind) of the bus if fire is present.
- Lead students as far away from railroad tracks as possible and in the direction of any oncoming train.
- Lead students upwind of the bus at least 300 feet if there is a risk from spilled HazMat.
- If the bus is in the direct path of a sighted tornado and evacuation is ordered, escort students to a nearby ditch or culvert if shelter in a building is not readily available, and direct them to lie face down, hands covering their head. They should be far enough away so the bus cannot topple on them. Avoid areas that are subject to flash floods.

General Procedures. Determine if evacuation is in the best interest of safety.

- Determine the best type of evacuation:
 - Front, rear, side door, or some combination of doors evacuation.
 - Roof or window evacuation.
- Secure the bus by:
 - Placing transmission in Park or, if there is no shift point, in Neutral.
 - Setting the parking brakes.
 - Shutting off the engine.
 - Removing the ignition key.
 - Activating the hazard-warning lights.
 - If time allows, notifying your dispatch office of the evacuation location, conditions, and type of assistance needed.
- Dangle the radio microphone or telephone out of the driver's window and take your cell phone for later use, if operable.
- If there is no radio or cell phone or they are inoperable, dispatch a passing motorist or area resident to call for help. As a last resort, dispatch 2 older, responsible students to go for help.
- Order the evacuation.
- Evacuate the students from the bus.
 - Do not move a student you believe may have suffered a neck or spinal injury unless his or her life is in immediate danger.
 - Special procedures must be used to move neck spinal injury victims to prevent further injury.
- Direct a student assistant to lead students to the nearest safe place.
- Walk through the bus to ensure no students remain on the bus. Retrieve emergency equipment.
- Join waiting students. Account for all students and check for their safety.
- Protect the scene. Set out emergency warning devices as necessary and appropriate.
- Prepare information for emergency responders.

10.4 – RAILROAD-HIGHWAY GRADE CROSSINGS

10.4.1 – Types of Crossings

Passive Crossings. This type of crossing does not have any type of traffic control device. You must stop at these crossings and follow proper procedures. However, the decision to proceed rests entirely in your hands. Passive crossings require you to recognize the crossing, search for any train(s) using the tracks, and decide if there is sufficient clear space to cross safely. Passive crossings have yellow circular advance warning signs, pavement markings, and crossbucks to assist you in recognizing a crossing.

Active Crossings. This type of crossing has a traffic control device installed at the crossing to regulate traffic at the crossing. These active devices include flashing red lights with or without bells, and flashing red lights with bells and gates.

10.4.2 – Warning Signs and Devices

Advance Warning Signs. This round, black-on-yellow warning sign is placed ahead of a public railroad-highway crossing. The advance warning sign tells you to slow down, look and listen for the train, and be prepared to stop at the tracks if a train is coming. See Figure 10.5.



Figure 10.5

Pavement Markings. Pavement markings mean the same as the advance warning sign. They consist of an "X" with the letters "RR" and a no-passing marking on 2-lane roads.

There is also a no passing zone sign on 2-lane roads. There may be a white stop line painted on the pavement before the railroad tracks. The front of the school bus must remain behind this line while stopped at the crossing. See Figure 10.6.



Figure 10.6

Crossbuck Signs. This sign marks the crossing. It requires you to yield the right-of-way to the train. If there is no white line painted on the pavement, you must stop the bus before the crossbuck sign. When the road crosses over more than one set of tracks, a sign below the crossbuck indicates the number of tracks. See Figure 10.7.

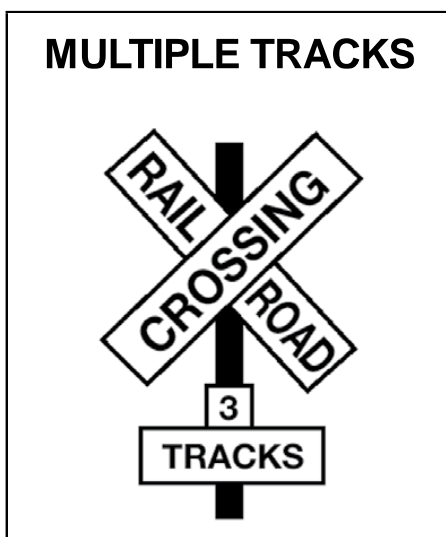

Figure 10.7

Flashing Red Light Signals. At many railroad-highway crossings, the crossbuck sign has flashing red lights and bells. When the lights begin to flash, you must stop! A train is approaching. You are required to yield the right-of-way to the train. If there is more than 1 track, make sure all tracks are clear before crossing. See Figure 10.8.

Gates. Many railroad-highway crossings have gates with flashing red lights and bells. Stop when the lights begin to flash and before the gate lowers across the road lane. Remain stopped until the gates go up and the lights have stopped flashing. Proceed when it is safe. If the gate stays down after the train passes, do not drive around the gate. Instead, call your dispatcher. See Figure 10.8.

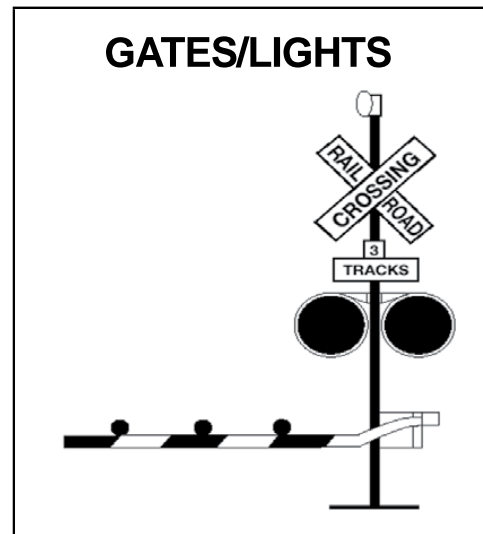

Figure 10.8

10.4.3 – Recommended Procedures

Each state has laws and regulations governing how school buses must operate at railroad-highway crossings. It is important for you to understand and obey these state laws and regulations. In general, school buses must stop at all crossings, and drivers must ensure it is safe before proceeding across the tracks. The specific procedures required in each state vary.

A school bus is one of the safest vehicles on the highway. However, a school bus does not have the slightest edge when involved in an accident with a train. Because of a train's size and weight it cannot stop quickly. An emergency escape route does not exist for a train. You can prevent school bus/train accidents by following these recommended procedures.

- **Approaching the Crossing:**
 - Slow down, including shifting to a lower gear in a manual transmission bus, and test your brakes.
 - Activate hazard lights approximately 200 feet before the crossing. Make sure your intentions are known.
 - Scan your surroundings and check for traffic behind you.
 - Stay to the right of the roadway if possible.
 - Choose an escape route in the event of a brake failure or problems behind you.
- **At the Crossing:**
 - Stop no closer than 15 feet and no farther than 50 feet from the nearest rail, where you have the best view of the tracks.
 - Place the transmission in Park or, if there is no Park shift point, in Neutral and press down on the service brake or set the parking brakes.
 - Turn off all radios and noisy equipment, and silence the passengers.
 - Open the service door and driver's window. Look and listen for an approaching train.
- **Crossing the Track:**
 - Check the crossing signals again before proceeding.
 - At a multiple-track crossing, stop only before the first set of tracks. When you are sure no train is approaching on any track, proceed across all of the tracks until you have completely cleared them.
 - Cross the tracks in a low gear. Do not change gears while crossing.
 - If the gate comes down after you have started across, drive through it, even if it means you will break the gate.

10.4.4 – Special Situations

Bus Stalls or Is Trapped on the Tracks. If your bus stalls or is trapped on the tracks, get everyone out and off the tracks immediately. Move everyone far from the bus at an angle, which is both away from the tracks and toward the train.

Police Officer at the Crossing. If a police officer is at the crossing, obey directions. If there is no police officer, and you believe the signal is malfunctioning, call your dispatcher to report the situation and ask for instructions on how to proceed.

Obstructed View of Tracks. Plan your route so it provides maximum sight distance at railroad-highway crossings. Do not attempt to cross the tracks unless you can see far enough down the track to know for certain that no trains are approaching. Passive crossings are those that do not have any type of traffic control device. Be especially careful at “passive” crossings. Even if there are active railroad signals that indicate the tracks are clear, you must look and listen to be sure it is safe to proceed.

Containment or Storage Areas. If it will not fit, do not commit! Know the length of your bus and size of the containment area at railroad-highway crossings on the school bus route, as well as any crossing you encounter in the course of a school activity trip. When approaching a crossing with a signal or stop sign on the opposite side, pay attention to the amount of room there. Be certain the bus has enough containment or storage area to completely clear the railroad tracks on the other side if there is a need to stop. As a general rule, add 15 feet to the length of the school bus to determine an acceptable amount of containment or storage area.

10.5 – STUDENT MANAGEMENT

10.5.1 – Do Not Deal With On-Bus Problems When Loading and Unloading

In order to get students to and from school safely and on time, you need to be able to concentrate on the driving task.

Loading and unloading requires all your concentration. Do not take your eyes off what is happening outside the bus.

If there is a behavior problem on the bus, wait until the students unloading are safely off the bus and have moved away. If necessary, pull the bus over to handle the problem.

10.5.2 – Handling Serious Problems

Tips on handling serious problems:

- Follow your school's procedures for discipline or refusal of rights to ride the bus.
- Stop the bus. Park in a safe location off the road, perhaps a parking lot or driveway.
- Secure the bus. Take the ignition key with you if you leave your seat.
- Stand up and speak respectfully to the offender or offenders. Speak in a courteous manner with a firm voice. Remind the offender of the expected behavior. Do not show anger, but do show that you mean business.
- If a change of seating is needed, request that the student move to a seat near you.
- Never put a student off the bus except at school or their designated school bus stop. If you feel the offense is serious enough that you cannot safely drive the bus, call a school administrator or the police to come and remove the student.
- Always follow your state or local procedures for requesting assistance.

10.6 – ANTI-LOCK BRAKING SYSTEMS

10.6.1 – Vehicles Required to Have ABS

The U.S. DOT requires that ABS be on:

- Air brake vehicle, (trucks, buses, trailers, and converter dollies) built on or after March 1, 1998.
- Hydraulic-braked trucks and buses with a GVWR of 10,000 pounds or more, built on or after March 1, 1999.

Many buses built before these dates have been voluntarily equipped with ABS.

Your school bus will have a yellow ABS malfunction lamp on the instrument panel if equipped with ABS.

10.6.2 – How ABS Helps You

When you brake hard on slippery surfaces in a vehicle without ABS, your wheels may lock up. When your steering wheels lock up, you lose steering control. When your other wheels lock up, you may skid or even spin the vehicle.

ABS helps you avoid wheel lock up and maintain control. You may or may not be able to stop faster with ABS, but you should be able to steer around an obstacle while braking, and avoid skids caused by over braking.

10.6.3 – Braking With ABS

When you drive a vehicle with ABS, you should brake as you always have. In other words:

- Use only the braking force necessary to stop safely and stay in control.
- Brake the same way, regardless of whether you have ABS on the bus. However, in emergency braking, do not pump the brakes on a bus with ABS.
- As you slow down, monitor your bus and back off the brakes (if it is safe to do so) to stay in control.

10.6.4 – Braking if ABS Is Not Working

Without ABS, you still have normal brake functions. Drive and brake as you always have.

Vehicles with ABS have yellow malfunction lamps to tell you if something is not working. The yellow ABS malfunction lamp is on the bus instrument panel.

As a system check on newer vehicles, the malfunction lamp comes on at start-up for a bulb check and then goes out quickly. On older systems, the lamp could stay on until you are driving over 5 mph.

If the lamp stays on after the bulb check, or goes on once you are under way, you may have lost ABS control at 1 or more wheels.

Remember, if your ABS malfunctions, you still have regular brakes. Drive normally, but get the system serviced soon.

10.6.5 – Safety Reminders

ABS will not:

- Allow you to drive faster, follow more closely, or drive less carefully.
- Prevent power or turning skids. ABS should prevent brake-induced skids but not those caused by spinning the drive wheels or going too fast in a turn.
- Necessarily shorten stopping distance. ABS will help maintain vehicle control, but not always shorten stopping distance.
- Increase or decrease ultimate stopping power. ABS is an “add-on” to your normal brakes, not a replacement for them.
- Change the way you normally brake. Under normal brake conditions, your vehicle will stop as it always stopped. ABS only comes into play when a wheel would normally have locked up because of over braking.
- Compensate for bad brakes or poor brake maintenance.

REMEMBER:

- The best vehicle safety feature is still a safe driver.
- Drive so you never need to use your ABS.
- If you need it, ABS could help prevent a serious accident.

10.7 – SPECIAL SAFETY CONSIDERATIONS

10.7.1 – Strobe Lights

Some school buses are equipped with roof-mounted, white strobe lights. If your bus is so equipped, the overhead strobe light should be used when you have limited visibility. This means that you cannot easily see around you—in front, behind, or beside the school bus. Your visibility could be only slightly limited or be so bad that you can see nothing at all. Use strobe lights only when visibility is reduced to 500 feet or less due to atmospheric conditions including, but not limited to, fog, rain, snow, smoke, or dust (CVC §25257.7).

10.7.2 – Driving in High Winds

Strong winds affect the handling of the school bus! The side of a school bus acts like a sail on a sailboat. Strong winds can push the school bus sideways. They can even move the school bus off the road or, in extreme conditions, tip it over.

If you are caught in strong winds:

- Keep a strong grip on the steering wheel. Try to anticipate gusts.
- You should slow down to lessen the effect of the wind, or pull off the roadway and wait.
- Contact your dispatcher to get more information on how to proceed.

10.7.3 – Backing

Backing a school bus is strongly discouraged. You should back your bus only when you have no other safe way to move the vehicle. You should never back a school bus when students are outside of the bus. Backing is dangerous and increases your risk of an accident. If you have no choice and you must back your bus, follow these procedures:

- To warn other motorists or pedestrians on a roadway during a backing maneuver, the operator of a school bus may flash hazard lights (CVC §25257.5).
- Post a lookout. The purpose of the lookout is to warn you about obstacles, approaching persons, and other vehicles. The lookout should not give directions on how to back the bus.
- Signal for quiet on the bus.
- Constantly check all mirrors and rear windows.
- Back slowly and smoothly.
- If no lookout is available:
 - Set the parking brake.
 - Turn off the motor and take the keys with you.
 - Walk to the rear of the bus to determine whether the way is clear.
- If you must back up at a student pick up point, be sure to pick up students before backing and watch for late comers at all times.
- Be sure that all students are in the bus before backing.
- If you must back up at a student drop off point, be sure to unload students after backing.

10.7.4 – Tail Swing

A school bus can have up to a 3-foot tail swing. You need to check your mirrors before and during any turning movements to monitor the tail swing.

SECTION 10

Test Your Knowledge

1. Define the danger zone. How far does the danger zone extend around the bus?
2. What should you be able to see if the outside flat mirrors are adjusted properly? The outside convex mirrors? The crossview mirrors?
3. You are loading students along the route. When should you activate your alternating flashing amber warning lights?
4. You are unloading students along your route. Where should students walk to after exiting the bus?
5. After unloading at school, why should you walk through the bus?
6. What position should students be in, in front of the bus, before they cross the roadway?
7. Under what conditions must you evacuate the bus?
8. How far from the nearest rail should you stop at a railroad-highway crossing?
9. What is a passive railroad-highway crossing? Why should you be extra cautious at this type of crossing?
10. How should you use your brakes if your vehicle is equipped with ABS?

These questions may be on your test. If you cannot answer them all, reread Section 10.



Keep your
EYES moving
and **SCAN** your
surroundings
to **AVOID**
HAZARDS!



Safe driving practices:
www.dmv.ca.gov

SECTION 11: VEHICLE INSPECTION TEST

THIS SECTION COVERS

- 11.1 – All Vehicles
- 11.2 – Internal Inspection (All Vehicles)
- 11.3 – External Inspection (All Vehicles)
- 11.4 – School Bus Only
- 11.5 – Trailer
- 11.6 – Coach/Transit Bus
- 11.7 – Taking the CDL Vehicle Inspection Test

11.1 – ALL VEHICLES

The vehicle inspection test is a skills test to see if the customer identifies which features and equipment on the test vehicle should be inspected before operating the vehicle. Interpreters are prohibited. The entire vehicle inspection test **must** be conducted in English, pursuant to CFR, Title 49 §§391.11(b)(2) and 383.133(c)(5).

If you communicate in a language other than English, or fail to comprehend instructions given to you in English, during the skills tests (vehicle inspection, basic control skills, and road test), you will receive a verbal warning for the first 2 offenses committed on the same test date. Upon the third offense committed on the same test date, the test will end as an automatic failure.

A vehicle inspection should be done the same way each time so you will learn all the steps and be less likely to forget something during the test.

Vehicle inspection tests are conducted to ensure that a vehicle is safe to operate. During the vehicle inspection test, you will be expected to explain or show your knowledge of the vehicle inspection process.

During the vehicle inspection test, you **must** show that the vehicle is safe to drive. You will have to walk around the vehicle, name, point to, or touch each item and explain to the examiner what you are checking and why. Any vehicle that has components marked or labeled cannot be used for the vehicle inspection test. The brake lights, emergency flashers, turn signals, and horn must be checked. If any of these items do not work, the skills and road portions of the test will be postponed.

You may use the guides shown on the last page of this section when taking your vehicle inspection test. You cannot write any instructions or notes on the vehicle inspection guide. If you do not pass the vehicle inspection test, the other tests will be postponed.

REMEMBER: You are allowed a total of 3 attempts to pass the vehicle inspection, basic control skills, and road tests.

11.2 – INTERNAL INSPECTION (ALL VEHICLES)

Study the following vehicle parts for the type of vehicle you will be using during the CDL skills tests. You should be able to identify each part and tell the examiner what you are looking for or inspecting.

As you approach the vehicle, notice its general condition. Look for damage or the vehicle leaning to one side. Look under the vehicle for fresh oil, coolant, grease, or fuel leaks. Check area around the vehicle for hazards to vehicle movement such as people, other vehicles, objects, low hanging wires, or limbs, etc.

Check that the parking brakes are set and/or wheels chocked. You may have to raise the hood or open the engine compartment door. Check the following:

11.2.1 – Engine Compartment (Engine Off)

Leaks/Hoses

- Look for puddles on the ground.
- Look for dripping fluids on underside of the engine and transmission.
- Inspect hoses for condition and leaks.
- Water Pump.
 - Identify the water pump.
 - Identify that the water pump is mounted securely and not leaking.
- Alternator.
 - Identify the alternator.
 - Check that the alternator is securely mounted and all wires are securely fastened.
- Air Compressor.
 - Identify the air compressor.
 - Check that the air compressor is securely mounted and not leaking.

Oil Level

- Check the oil level when the engine is off.
- Indicate where the dipstick is located.
- See that the oil level is within safe operating range. The level must be above the refill mark.

Coolant Level

Look at the sight glass on the radiator or coolant reservoir; the adequate level will show in sight glass. If no sight glass is available, you must describe what you would look for after removing radiator cap.

Power Steering Fluid

Check the dipstick and see where the fluid is relative to the refill mark or check the sight glass. The level must be above the refill mark.

Windshield Washer Fluid Level

Check the fluid level and that the cap is secure.

Engine Compartment Belts

- Check the following belts for snugness (1/2 to 3/4 inch play at center of the belt), cracks, frays, loose fibers, or signs of wear:
 - Power steering belt.
 - Water pump belt.
 - Alternator belt.
 - Air compressor belt.

NOTE: If any of the components listed above are not belt driven, you must:

- Tell the examiner which component(s) are not belt driven.
- Make sure the component(s) are operating properly, not damaged or leaking, and mounted securely.

Hydraulic Brakes Master Cylinder and Brake Fluid

- Check that the master cylinder is securely attached and not leaking.
- Check the level of brake fluid in the reservoir to ensure it is between the add and full marks.

Safe Start

- Place the gearshift lever in Neutral (or Park, for automatic transmissions).
- Depress the clutch before attempting to start the vehicle.
- Start the vehicle and keep the clutch depressed until the engine reaches idling speed, then release the clutch slowly.

11.2.2 – Cab Check/Engine Start

Oil Pressure Gauge

- Make sure the oil pressure gauge is working.
- Check that the pressure gauge shows increasing or normal oil pressure or that the warning light goes off.
- If equipped, the oil temperature gauge should begin a gradual rise to the normal operating range.

Temperature Gauge

- Make sure the temperature gauge is working.
- The temperature should begin to climb to the normal operating range or the temperature light should be off.

Air Gauge

- Make sure the air gauge is working properly.
- Build the air pressure to the governor cut-out, approximately 120–140 psi or as specified by the manufacturer.

Ammeter/Voltmeter

Check that the gauges show that the alternator and/or generator is charging or that the warning light is off.

Mirrors and Windshield

- The mirrors should be clean and adjusted properly from the inside.
- The windshield should be clean with no illegal stickers, obstructions, or damage to the glass.

Emergency Equipment

- Check for spare electrical fuses.
- Check for 3 red reflective triangles, 6 fuses or 3 liquid burning flares.
- Check that the fire extinguisher is properly charged and securely mounted.

NOTE: If the vehicle is not equipped with electrical fuses, you must mention this to the examiner.

Check Optional Emergency Equipment

- Tire chains (where winter conditions require them).
- Tire changing equipment.
- List of emergency phone numbers.
- Accident reporting kit (packet).

Wipers/Washers

- Check that the wiper arms and blades are secure, not damaged, and operate smoothly.
- If equipped, the windshield washers must operate correctly.

Lights/Reflectors/Reflector Tape Condition (Sides and Rear)

- Test that the dash indicators work when the corresponding lights are turned on:
 - Left turn signal.
 - Right turn signal.
 - 4-way emergency flashers.
 - High-beam headlight.
 - Anti-lock Braking System (ABS) indicator.
- Check that all the external lights and reflective equipment are clean and functional and not broken or missing. The light and reflector checks include verification of correct color:
 - Clearance lights (red on rear, amber elsewhere).
 - Headlights (high and low beams).
 - Taillights.
 - Backing lights.
 - Turn signals.
 - 4-way emergency flashers.
 - Brake lights.
 - Red reflectors (on rear) and amber reflectors (elsewhere).
 - Reflector tape condition.
 - License plate light(s).

NOTE: Checks of the brake, turn signals, and 4-way emergency flasher functions must be done separately.

Horn

Check that the air and/or electric horn(s) work.

Heater/Defroster

Test that the heater and defroster work.

Parking Brake Check

- Fasten your seat belt.
- With the air pressure built to governor cutout and the parking brake engaged (trailer brakes released on combination vehicles), check that the parking brake will hold the vehicle by gently trying to pull forward with the parking brake on.
- With the air pressure built to governor cutout, and the trailer parking brake engaged (combination vehicles only), check that the trailer parking brake will hold the vehicle by gently trying to pull forward with the trailer parking brake on.

Hydraulic Brake Check

- Pump the brake pedal 3 times, and then hold it down for 5 seconds. The brake pedal should not move (depress) during the 5 seconds.
- If equipped with a hydraulic brake reserve (back up) system, with the key off, depress the brake pedal and listen for the sound of the reserve system electric motor.
- If equipped with a “Hydro-Boost” brake system, with the engine off, release the parking brake, depress and release the brake pedal several times to deplete all hydraulic pressure. Depress and hold the brake pedal with light pressure (15–25 pounds) and then start the engine and run it at idle speed. If the Hydro-Boost is operating, the pedal will yield slightly to foot pressure and then hold. Less pressure is required to hold the pedal at this position.
- Check that the warning buzzer or light is off.

NOTE: Failure to perform both components of the hydraulic brake check will result in an automatic failure of the vehicle inspection test.

Air Brake Check (Air Brake-Equipped Vehicles Only)

Refer to Section 5, In-Cab Air Brake Check for DMV vehicle inspection testing. All items marked with an asterisk (*) are required during the vehicle inspection test. These items must be demonstrated and the parameters verbalized to receive credit. Failure to perform these air brake tests correctly will result in an automatic failure for the entire vehicle inspection portion of the test.

Service Brake Check

You will be required to check the application of air or hydraulic service brakes. This procedure is designed to determine that the brakes are working correctly and the vehicle does not pull to one side or the other.

Pull forward at 5 mph, apply the service brake, and stop. Check to see that the vehicle does not pull to either side and it stops when the brake is applied.

Safety Belt

Check that the safety belt is securely mounted, adjusts, latches properly, and is not ripped or frayed.

11.3 – EXTERNAL INSPECTION (ALL VEHICLES)

11.3.1 – Steering

Steering Box/Hoses

- Check that the steering box is securely mounted and not leaking. Look for any missing nuts, and/or bolts.
- Check for power steering fluid leaks or damage to the power steering hoses.

Steering Linkage

- See that the connecting links, arms, and rods from the steering box to the wheel are not worn or cracked.
- Check that the joints and sockets are not worn or loose and that there are no missing nuts, bolts, or cotter keys.

11.3.2 – Suspension

Springs/Air/Torque

- Look for missing, shifted, cracked, or broken leaf springs. If 1/4 or more are missing or broken, it will put the vehicle “out of service.”
- Look for broken or distorted coil springs.
- If the vehicle is equipped with torsion bars, torque arms, or other types of suspension components, check that they are not damaged and are mounted securely.
- Air ride suspension should be checked for damage and leaks.

Mounts

Look for cracked or broken spring hangers, missing or damaged bushings, and broken, loose, or missing bolts, u-bolts, or other axle mounting parts. The mounts should be checked at each point where they are secured to the vehicle frame and axle(s).

Shock Absorbers

See that shock absorbers are secure and that there are no leaks.

NOTE: Be prepared to perform the same suspension components inspection on every axle (power unit and trailer, if equipped).

11.3.3 – Brakes

Slack Adjustors and Pushrods

- Check that the slack adjuster is securely mounted.
- Look for broken, loose, or missing parts.
- For manual slack adjustors, the brake pushrod should not move more than 1 inch (with the brakes released) when pulled by hand.

Brake Chambers

- See that the brake chambers are not leaking, cracked, or dented, and are mounted securely.
- See that there are no loose or missing clamps.

Brake Hoses/Lines

- Check that the hoses or lines can supply air or hydraulic fluid to the brakes.
- Check for cracked, worn, or frayed hoses and that all couplings and fittings are secured and not leaking.

Drum Brake

- Check for cracks, dents, or holes. Also, check for loose or missing bolts.
- Check for contaminants, such as debris or oil/grease.

Brake Linings

Brake linings (where visible) should not be worn dangerously thin. On some brake drums, there are openings where the brake linings can be seen from outside the drum. For this type of drum, check that a visible amount of brake lining is showing.

NOTE: Be prepared to perform the same brake components inspection on every axle (power unit and trailer, if equipped).

11.3.4 – Wheels

Rims

- Check for damaged or bent rims.
- Rims cannot have welding repairs.
- Check the rims for rust trails that may indicate the rim is loose on the wheel.

Tires

The following items must be inspected on every tire:

- Tread depth: Check for the minimum tread depth (4/32 on steering axle tires, 2/32 on all other tires).
- Tire condition: Check that the tread is evenly worn and look for cuts or other damage to tread or sidewalls. Also, make sure that valve caps and stems are not missing, broken, or damaged.
- Tires are the same the type (not mixed radial and bias). Front tires for buses cannot be re-capped, retreaded, or regrooved.
- Tire inflation: Check for proper inflation by using a tire gauge.

NOTE: You will not get credit for simply kicking the tires or striking the tire with a mallet or other similar device to check for proper inflation.

Hub Oil/Axle Seals

See that the hub oil/grease and axle seals are not leaking and, if the wheel has a sight glass, that the oil level is adequate.

Lug Nuts

- Check that all lug nuts are present, free of cracks and distortions, and show no signs of looseness such as rust trails or shiny threads.
- Make sure all bolt holes are not cracked or distorted.

Spacers or Budd Spacing

- If equipped, check that the spacers are not bent, damaged, or rusted through.
- The spacers should be evenly centered, with the dual wheels and tires evenly separated.
- Check that no debris and/or foreign objects are between dual tires.

NOTE: Be prepared to perform the same wheel inspection on every axle (power unit and trailer, if equipped).

11.3.5 – Side of Vehicle

Door(s)/Mirror(s)/Window(s)

- Check that the door(s) are not damaged and they open and close properly from the outside.
- Hinges should be secure with the seals intact.
- Check that the mirror(s) and mirror brackets are not damaged, are mounted securely with no loose fittings, and are free of excessive dirt.
- Windows must be clean and work properly.

Fuel Tank

Check that the tank(s) are secure, cap(s) are tight, and there are no leaks from tank(s), cap(s), or lines.

Drive Shaft

- See that the drive shaft is not bent or cracked.
- Couplings (U-joints) should be secure and free of foreign objects.

Exhaust System

- Check the system for damage and signs of leaks such as rust or carbon soot.
- The exhaust system should not have cracks, holes, or severe dents.
- The system should be connected tightly and mounted securely.

If equipped with emissions after-treatment equipment:

- Check the diesel exhaust fluid (DEF) tank to ensure the level of DEF in the tank is adequate (more than 1/8 tank).
- Check that the DEF indicator on the dash is working properly.

Frame

Look for cracks, broken welds, holes, or other damage to the longitudinal frame members, cross members, box, and floor.

11.3.6 – Rear of Vehicle

Splash Guards

If equipped, check that the splash guards or mud flaps are not damaged and are mounted securely.

Doors/Ties/Lifts

- Check that the doors and hinges are not damaged and they open, close, and latch properly from the outside, if equipped.
- Ties, straps, chains, and binders must be secure.
- If equipped with a cargo lift, look for leaking, damaged, or missing parts, and explain how it should be checked for correct operation.
- The lift must be fully retracted and latched securely.

11.3.7 – Tractor/Coupling

Air/Electric Connectors

Check that:

- The trailer air connectors are sealed and in good condition.
- The fittings out of the truck and trailer are secured.
- All connections from the truck to the trailer are secured.
- The trailer electrical plug is firmly sealed and locked in place on both the truck and trailer.

Air/Electric Lines

- Listen for air leaks. Check that the air hoses and electrical lines are not cut, chafed, spliced, or worn (steel braid should not show through).
- Make sure the air and electrical lines are not tangled, pinched, or dragging against tractor parts.

Catwalk/Steps

Check that the:

- Catwalk is solid, clear of objects, and securely bolted to the tractor frame.
- Steps leading to the cab entry and catwalk (if equipped) are solid, clear of objects, and securely bolted to the tractor frame.
- Storage area is solid to the tongue and the cargo in the storage area is secured.

Mounting Bolts

- Look for loose or missing mounting brackets, clamps, bolts, or nuts. Both the fifth-wheel and slide mounting must be solidly attached.
- On other types of coupling systems (for example, ball hitch, pintle hook, etc.), inspect all coupling components and mounting brackets for missing or broken parts.
- Check for loose or missing mounting bolts. Look for broken welds on the pintle hook or other hitch mount, and tongue/drawbar assembly to ensure they are solidly attached in place.

Hitch Release Lever

Check to see that the hitch release lever is in place and secure.

Locking Jaws

- Look into the fifth-wheel gap and check that the locking jaws are fully closed around the kingpin.
- On other types of coupling systems (ball hitch, pintle hook, etc.), inspect the locking mechanism for missing or broken parts and make sure it is locked securely. If present, safety cables or chains must be secure and free of kinks and excessive slack.

Fifth-Wheel Skid Plate

Check for proper lubrication, that the fifth-wheel skid plate is securely mounted to the platform, and all bolts and pins are secure and not missing.

Platform (Fifth-Wheel) (Pintle Hook)

- Check for cracks or breaks in the platform structure which supports the fifth-wheel skid plate.
- Check the pintle hook for cracks, breaks, or excessive wear.

Release Arm (Fifth-Wheel)

If equipped, make sure that the release arm is in the engaged position and the safety latch is in place.

Kingpin/Apron/Gap

- Explain that the locking jaws holds the kingpin in place and the kingpin is not bent or damaged.
- Make sure that the visible part of the apron is not bent, cracked, or broken.
- Check that the trailer is lying flat on the fifth-wheel skid plate (no gap).
- Check for the kingpin lock.

Locking Pins (Fifth-Wheel)

- If equipped, look for loose or missing pins in the slide mechanism of the sliding fifth-wheel. If air powered, check for leaks.
- Make sure that the locking pins are fully engaged.
- Check that the fifth-wheel is positioned properly so that the tractor frame will clear the landing gear during turns.

Sliding Pintle

Check the sliding pintle hook for excessive wear and to ensure it is secure with no loose or missing nuts or bolts and the cotter pin is in place.

Tongue or Draw-Bar

- Check that the tongue/draw-bar is not bent or twisted and for broken welds and stress cracks.
- Check that the tongue/draw-bar eye is not worn excessively.

Tongue Storage Area

- Check that the storage area is solid and secured to the tongue.
- Check that the cargo in the storage area (chains, binders, etc.) is secure.

11.4 – SCHOOL BUS ONLY

Emergency Equipment

- In addition to checking for spare electrical fuses (if equipped), 3 red reflective triangles, 6 fuses or 3 liquid burning flares, and a properly charged and rated fire extinguisher; school bus drivers must also inspect the following emergency equipment:
 - Emergency kit.
 - Body fluid cleanup kit.

Lighting Indicators

- In addition to checking the lighting indicators listed in Section 10 of this handbook, school bus drivers must also check the following lighting indicators (internal panel lights):
 - Alternately flashing amber lights indicator, if equipped.
 - Alternately flashing red lights indicator.
 - Strobe light indicator, if equipped.

Lights/Reflectors

- In addition to checking the lights and reflective devices listed in Section 10 of this handbook, school bus drivers must also check the following (external) lights and reflectors:
 - Strobe light, if equipped, is operational and not broken.
 - Stop arm light, if equipped.
 - Alternately flashing amber lights, if equipped, are operational and not broken.
 - Alternately flashing red lights, on the front and back of the vehicle are operational and not broken.

Student Mirrors

- In addition to checking the external mirrors, school bus drivers must also check the internal and external mirrors used for observing students:
 - Check for proper adjustment.
 - Check that all internal and external mirrors and mirror brackets are not damaged and are mounted securely with no loose fittings.
 - Check that visibility is not impaired due to dirty mirrors.

Stop Arm/Safety Arm

If equipped, check the stop arm to see that it is mounted securely to the frame of the vehicle. Also, check for loose fittings and damage. Check that the stop arm extends fully when operated.

Passenger Entry/Lift

- Check that the entry door is not damaged, operates smoothly, and closes securely from the inside.
- Check that the hand rails are secure and the step light is working, if equipped.
- Check that the entry steps are clear with the treads not loose or worn excessively.
- If equipped with a handicap lift, look for leaking, damaged, or missing parts, and explain how a lift should be checked for correct operation.
- The lift must be fully retracted and latched securely.
- Make sure the lift control interlock(s) functions properly.

Emergency Exit

- Demonstrate that at least 1 emergency exit is not damaged, operates smoothly, and closes securely from the inside.
- Check that the release handle can be operated properly from both inside and outside the vehicle.
- Point out and describe how all other emergency exits operate.
- Check that any emergency exit warning devices are working properly.

Passenger Seating

- Look for broken seat frames and check that the seat frames are firmly attached to the floor.
- Check that the seat cushions are attached securely to the seat frames.

11.5 – TRAILER

11.5.1 – Trailer Front

Air/Electrical Connections

- Check that the trailer air connectors are sealed and in good condition.
- Make sure that the glad hands are locked in place, and free of damage or air leaks.
- Make sure that the trailer electrical plug is firmly seated and locked in place.

Header Board

- If equipped, check the header board to see that it is secure, free of damage, and strong enough to contain cargo.
- If equipped, the canvas or tarp carrier must be mounted and fastened securely.
- On enclosed trailers, check the front area for signs of damage such as cracks, bulges, holes, or missing rivets.

11.5.2 – Side of Trailer

Landing Gear

- Check that the landing gear is fully raised, has no missing parts, crank handle is secure, and support frame and landing pads are not damaged.
- If power operated, check for air or hydraulic leaks.

Doors/Ties/Lifts

- If equipped, check that the doors are not damaged. Check that the doors open, close, and latch properly from the outside.
- Check that the ties, straps, chains, and binders are secure.
- If equipped with a cargo lift, look for leaking, damaged, or missing parts, and explain how it should be checked for correct operation.
- The lift should be fully retracted and latched securely.

Frame

Look for cracks, broken welds, holes, or other damage to the frame, cross members, box, and floor.

Tandem Release Arm/Locking Pins

If equipped, make sure the locking pins are locked in place and the release arm is secured.

11.5.3 – Remainder of Trailer

Remainder of Trailer

- Please refer to Section 11.3, External Inspection (All Vehicles) of this handbook for detailed inspection procedures regarding the following components:
 - Wheels.
 - Suspension system.
 - Brakes.
 - Doors/ties/lift.
 - Splash guards.

11.6 – COACH/TRANSIT BUS

11.6.1 – Passenger Items

Passenger Entry/Lift

- Check that the entry doors operate smoothly and close securely from the inside.
- Check that the hand rails are secure and, if equipped, that the step light(s) are working.
- Check that the entry steps are clear, and the treads are not loose or worn excessively.
- If equipped with a handicap lift, look for any leaking, damaged, or missing part, and explain how it should be checked for correct operation.
- The lift should be fully retracted and latched securely.
- Make sure the lift control interlock(s) functions properly.

Emergency Exits

Demonstrate that at least 1 emergency exit is not damaged, operates smoothly, and closes securely from inside.

- Show that the release handle can be operated properly from both inside and outside of the vehicle.
- Point out and describe how all other emergency exits operate.
- Check that any emergency exit warning devices are working properly.

Passenger Seating

- Look for broken seat frames and check that the seat frames are firmly attached to the floor.
- Check that the seat cushions are attached securely to the seat frames.

11.6.2 – Entry/Exit

Doors/Mirrors

- Check that the entry/exit doors are not damaged and operate smoothly from the outside. The hinges should be secure with seals intact.
- Make sure that the passenger exit mirrors, all external mirrors, and mirror brackets are not damaged and are mounted securely with no loose fittings.

11.6.3 – External Inspection of Coach/ Transit Bus

Level/Air Leaks

See that the vehicle is sitting level (front and rear), and, if air-equipped, check for audible air leaks from the suspension system.

Fuel Tank(s)

See that the fuel tank(s) are secure with no leaks from the tank(s) or lines.

Baggage Compartments

Check that the baggage and all other exterior compartment doors are not damaged, operate properly, and latch securely.

Battery/Box

- Wherever located, see that the battery(ies) are secure, connections are tight, and cell caps are present.

- Battery connections should not show signs of excessive corrosion.
- Check that the battery box and cover or door are not damaged and are secure.

11.6.4 – Remainder of Coach/Transit Bus

Remainder of Vehicle

- Refer to Section 11.3, External Inspection (All Vehicles) of this handbook for detailed inspection procedures for the remainder of the vehicle.

REMEMBER: The vehicle inspection test must be passed before you can proceed to the basic vehicle control skills test.

11.7 – TAKING THE CDL VEHICLE INSPECTION TEST

11.7.1 – Class A Vehicle Inspection Test

If you are applying for a Class A CDL, you will be required to perform 1 of 4 versions of a vehicle inspection in the vehicle you brought for testing. Each of the 4 tests are equivalent and you will not know which test you take until just before testing begins. Tests include an engine start, in-cab inspection, and inspection of the coupling system. Your test may require an inspection of the entire vehicle or only a portion of the vehicle, which your CDL examiner will explain to you.

11.7.2 – Class B and C Vehicle Inspection Test

If you are applying for a Class B or Class C CDL, you will be required to perform 1 of 3 versions of a vehicle inspection in the vehicle you brought for testing. Each of 3 tests are equivalent and you will not know which test you take until just before testing begins. Tests include an engine start and in-cab inspection. Your test may require an inspection of the entire vehicle or only a portion of the vehicle, which your CDL examiner will explain to you. You will also have to inspect any special features of your vehicle (for example, school or transit bus).

CDL Vehicle Inspection Memory Aid

Combination Vehicles

Straight Truck or Bus

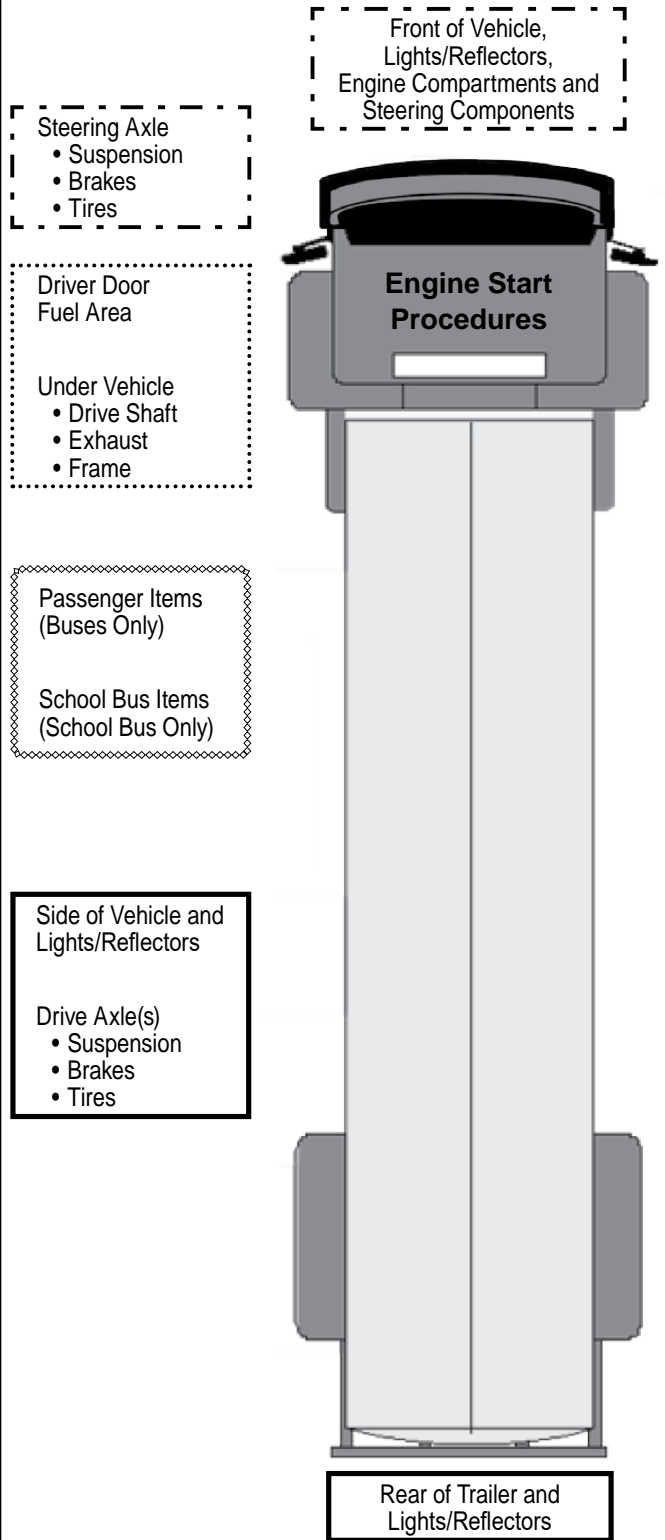
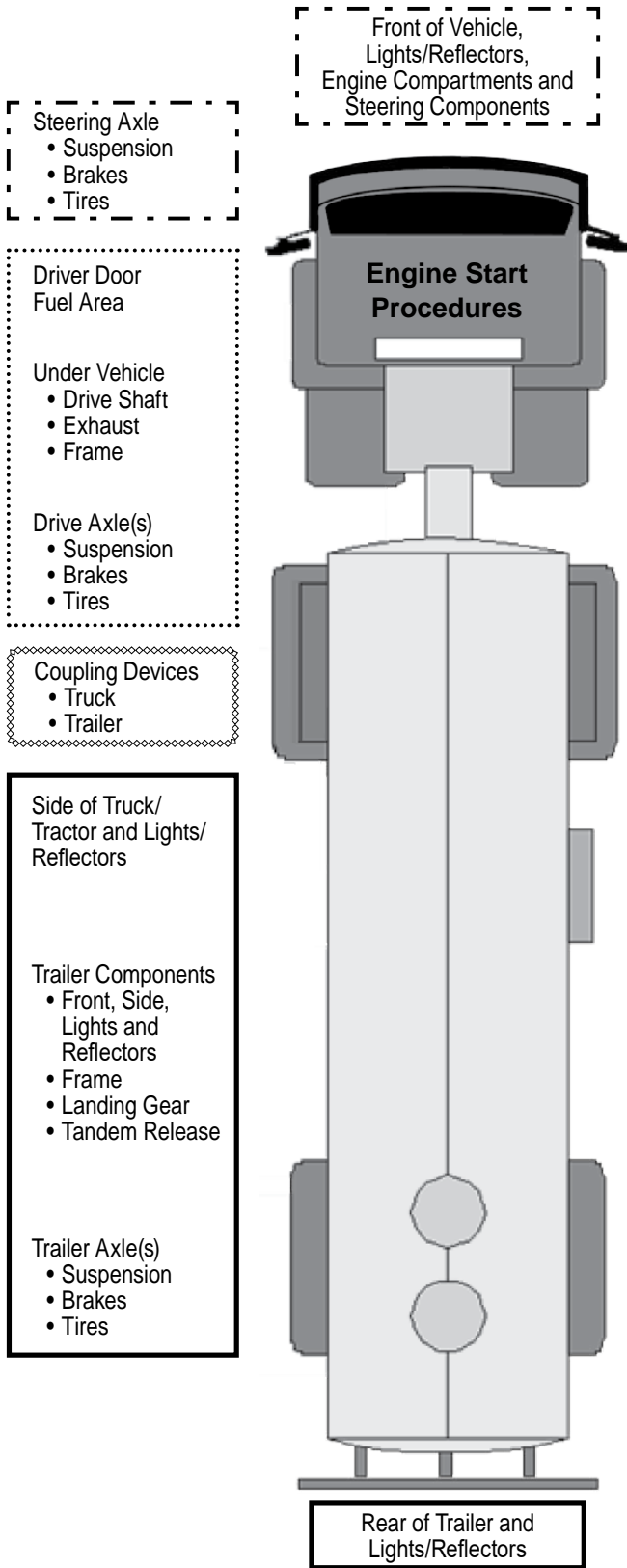

Must be covered on all forms for applicable vehicle
 Form A
 Form B
 Form C

SECTION 12: BASIC CONTROL SKILLS TEST

THIS SECTION COVERS

- 12.1 – Skills Test Scoring
- 12.2 – Skills Test Exercises

Interpreters are prohibited. The entire basic control skills test **must** be conducted in English, pursuant to CFR, Title 49 §§391.11(b)(2) and 383.133(c)(5). Technology, such as backup cameras and self-parking, **cannot** solely be used on a skills test.

If you communicate in a language other than English, or fail to comprehend instructions given to you in English, during the skills tests (vehicle inspection, basic control skills, and road test), you will receive a verbal warning for the first 2 offenses committed on the same test date. Upon the third offense committed on the same test date, the test will end as an automatic failure.

The purpose of the basic control skills test is to evaluate your skill in controlling the vehicle and judging its position and relation to other objects while maneuvering through various exercises. The judgement and skill required for each exercise can apply to many different driving situations.

You will be tested on a subset of the following exercises:

- Straight line backing.
- Offset back/right.
- Offset back/left.
- Parallel park (driver side).
- Parallel park (conventional).
- Alley dock.

NOTE: Refusing or failing to complete a basic control skills test exercise as instructed may result in an automatic failure.

These exercises are shown in Figures 12.1 through 12.6.

12.1 – SKILLS TEST SCORING

Your performance on the basic control skills test is scored by the examiner. You will be scored for the following:

- Encroachments (crossing boundaries).
- Pull ups.
- Outside vehicle observations (looks).
- Final position/inside parallel.

Encroachments—The examiner will score the number of times you touch or cross over an exercise boundary line or cone with any portion of your vehicle. Each encroachment will count as an error.

Pull Ups—When a driver stops and pulls forward to clear an encroachment or get a better position, it is scored as a “pull up.” Stopping without changing direction does not count as a pull up. You will not be penalized for initial pull ups. However, an excessive number of pull ups will count as errors.

Outside Vehicle Observations (Looks)—You may be permitted to safely stop and exit the vehicle to check the external position of your vehicle (look). When doing so, you must place the vehicle in Neutral and set the parking brake(s). Then, when exiting the vehicle, you must do so safely by facing the vehicle and maintaining 3 points of contact with the vehicle at all times (when exiting a bus, maintain a firm grasp on the handrail at all times). If you do not safely secure the vehicle or safely exit the vehicle, it may result in an automatic failure of the basic control skills test.

The maximum number of times you may look to check the position of your vehicle is 2, except for the straight line backing exercise, which allows only 1 look. Each time you open the door, move from a seated position where in physical control of the vehicle, or on a bus walk to the back of a bus to get a better view, is scored as a “look.”

Final Position/inside parallel—It is important that you finish each exercise exactly as the examiner has instructed. If you do not maneuver the vehicle into its final position as described by the examiner, you will be penalized and could fail the basic skills test.

12.2 – SKILLS TEST EXERCISES

These exercises are shown in Figures 12.1 through 12.6.

12.2.1 – Straight Line Backing

You may be asked to back your vehicle in a straight line between 2 rows of cones without touching or crossing over the exercise boundaries. See Figure 12.1.

12.2.2 – Offset Back/Right

You may be asked to back into a space that is to the right rear of your vehicle. You will drive straight toward the outer boundary. From that position, you must back the vehicle into the **opposite** lane until the front of your vehicle has passed the first set of cones without striking boundary lines or cones. See Figure 12.2.

12.2.3 – Offset Back/Left

You may be asked to back into a space that is to the left rear of your vehicle. You will drive straight toward the outer boundary. From that position, you must back the vehicle into the **opposite** lane until the front of your vehicle has passed the first set of cones without striking boundary lines or cones. See Figure 12.3.

12.2.4 – Parallel Park (Driver Side)

You may be asked to park in a parallel parking space that is on your left. You will drive past the entrance to the parallel parking space with your vehicle parallel to the parking area, and then back into the space without crossing front, side, or rear boundaries marked by cones. You are required to get your entire vehicle completely into the space. See Figure 12.4.

12.2.5 – Parallel Park (Conventional)

You may be asked to park in a parallel parking space that is on your right. You will drive past the entrance to the parallel parking space with your vehicle parallel to the parking area, and then back into the space without crossing front, side, or rear boundaries marked by cones. You are required to get your entire vehicle completely into the space. See Figure 12.5.

12.2.6 – Alley Dock

You may be asked to sight-side back your vehicle into an alley. You will drive past the alley and position your vehicle parallel to the outer boundary. From that position, back into the alley, bringing the rear of your vehicle within 3 feet of the rear of the alley, without touching boundary lines or cones. Your vehicle must be straight within the alley/lane when completed. See Figure 12.6.

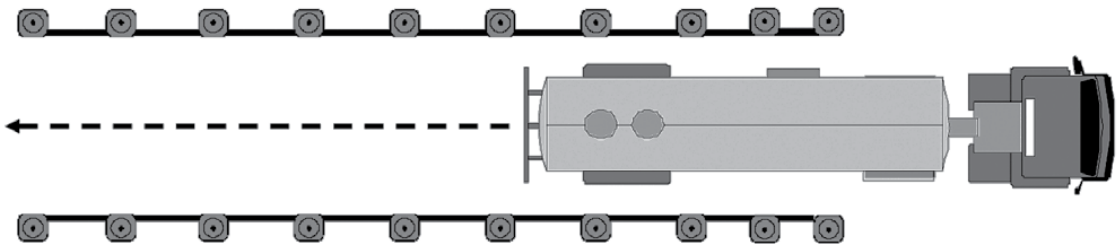

**Straight Line
Backing Figure 12.1**

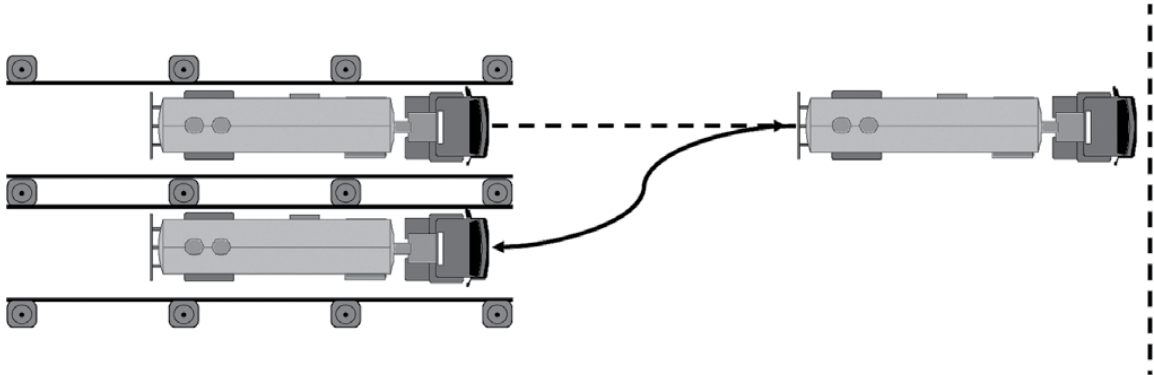

**Offset Back/Right
Figure 12.2**

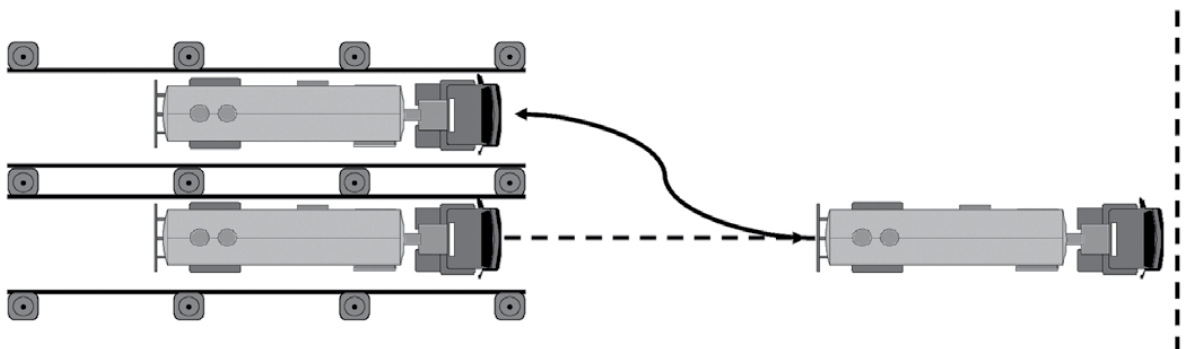

**Offset Back/Left
Figure 12.3**

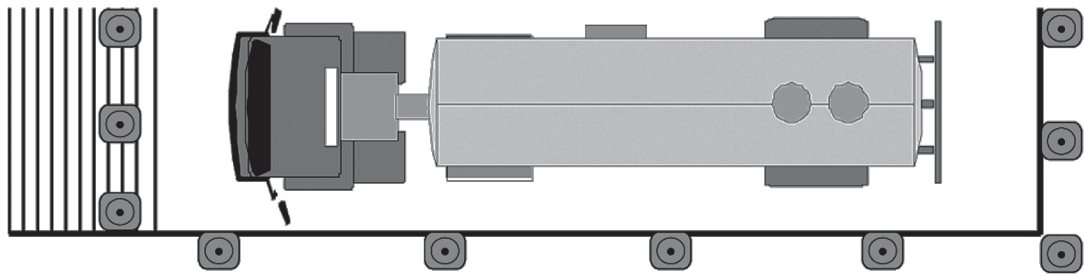

Parallel Park (Driver Side)
Figure 12.4

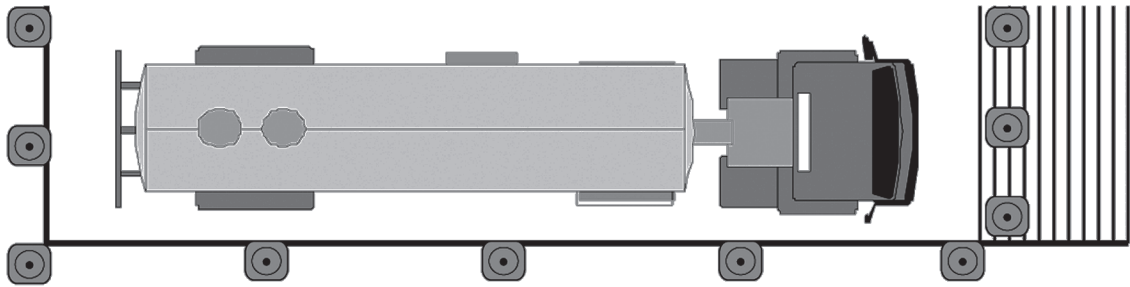

Parallel Park (Conventional)
Figure 12.5

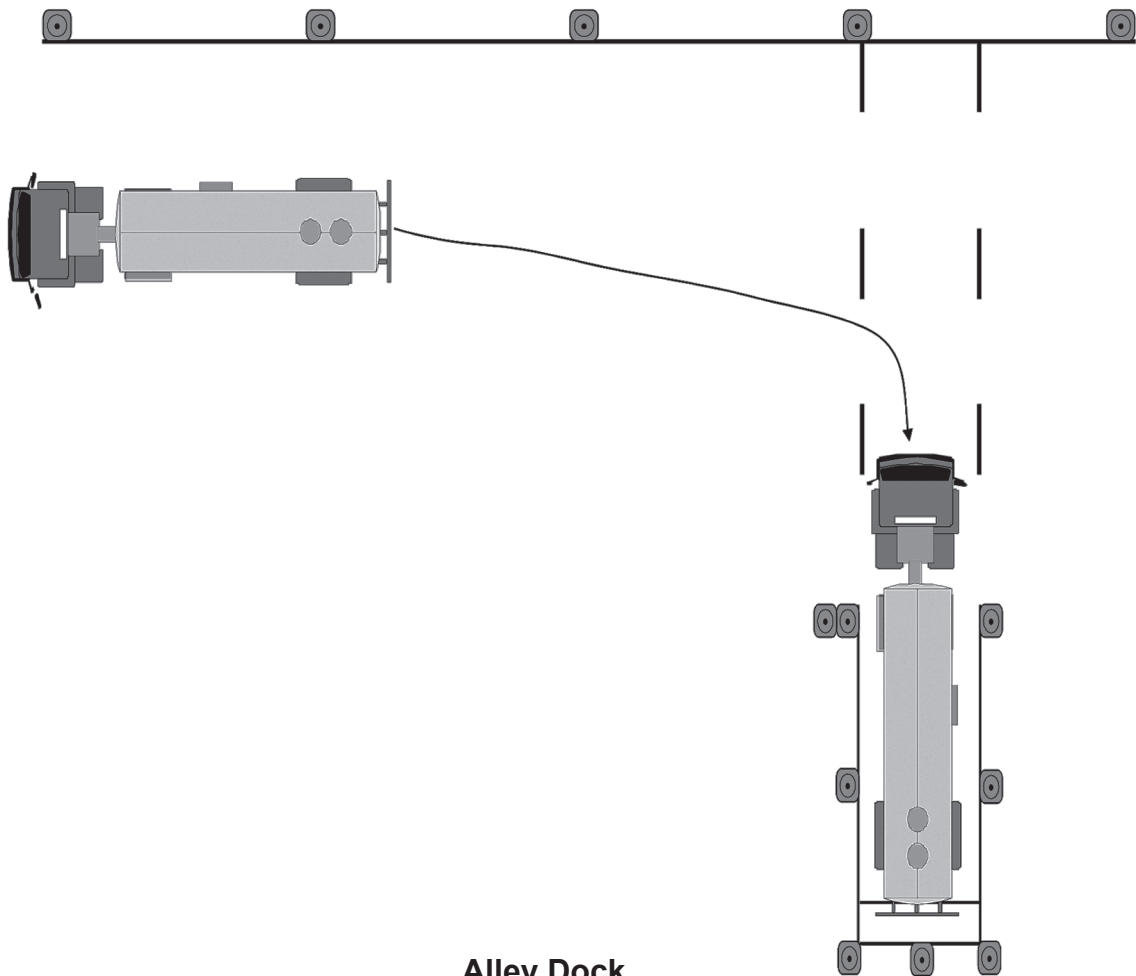

Alley Dock
Figure 12.6

SECTION 13: ROAD TEST

THIS SECTION COVERS

13.1 – How You Will Be Tested

To pass the road test portion of the CDL driving performance evaluation (DPE), you **must** make no more than 30 errors and no critical driving errors, which will result in an automatic failure. Interpreters are prohibited. The entire road test must be conducted in English pursuant to CFR, Title 49 §§391.11(b)(2) and 383.133(c)(5). Technology, such as backup cameras and self-parking, **cannot** solely be used on a road test.

If you communicate in a language other than English, or fail to comprehend instructions given to you in English, during the skills tests (vehicle inspection, basic control skills, and road test), you will receive a verbal warning for the first 2 offenses committed on the same test date. Upon the third offense committed on the same test date, the test will end as an automatic failure.

You will drive over a test route that has a variety of traffic situations. At all times during the test, you must drive in a safe and responsible manner and:

- Wear your safety belt.
- Obey all traffic signs, signals, and laws.
- Complete the test without an accident or moving violation.

During the driving test, the examiner will be scoring you on specific driving maneuvers as well as on your general driving behavior. You will follow the directions of the examiner. Directions will be given to you so you will have plenty of time to do what the examiner has asked. You will not be asked to drive in an unsafe manner.

If your test route does not have certain traffic situations, you may be asked to simulate a traffic situation. You will do this by telling the examiner what you are or would be doing if you were in that traffic situation.

Remember: You are allowed a total of 3 attempts to pass the vehicle inspection test, basic control skills test, and road test.

NOTE: A driver must be tested in a truck or bus (as those terms are defined in CFR, Title 49 §390.5), or other single unit vehicle with a GVWR of 26,001 or more, to satisfy the skills testing requirements for a Class B CDL.

13.1 – HOW YOU WILL BE TESTED

13.1.1 – Turns

You have been asked to make a turn:

- Check for traffic in all directions.
- Use turn signals and safely get into the lane needed for the turn.

As you approach the turn:

- Use turn signals to warn others of your turn.
- Slow down smoothly, change gears as needed to keep power, but do not coast unsafely. Unsafe coasting occurs when your vehicle is out of gear (clutch depressed or gearshift in Neutral) for more than the length of your vehicle.

If you must stop before making the turn:

- Come to a smooth stop without skidding.
- Come to a complete stop behind the stop line, crosswalk, or stop sign.
- If stopping behind another vehicle, stop where you can see the rear tires on the vehicle ahead of you (safe gap).
- Do not let your vehicle roll.
- Keep the front wheels aimed straight ahead.

When ready to turn:

- Check for traffic in all directions.
- Keep both hands on the steering wheel during the turn.
- Keep checking your mirror to make sure the vehicle does not hit anything on the inside of the turn.
- The vehicle should not move into oncoming traffic.
- The vehicle should finish the turn in the correct lane.

After the turn:

- Make sure your turn signal is off.
- Get up to the speed of traffic, use your turn signal, and move into the right-most lane when safe to do so (if not already there).
- Check your mirrors for traffic.

13.1.2 – Intersections

As you approach an intersection:

- Check for traffic thoroughly in all directions.
- Decelerate gently.
- Brake smoothly and, if necessary, change gears.
- If necessary, come to a complete stop (no coasting) behind any stop signs, signals, sidewalks, or stop lines, and maintain a safe gap behind any vehicle in front of you.
- Your vehicle must not roll forward or backward.

Note: Do not enter the intersection if there is insufficient space to clear it.

When driving through an intersection:

- Check for traffic thoroughly in all directions.
- Decelerate and yield to any pedestrians and traffic in the intersection.
- Do not change lanes while proceeding through the intersection.
- Keep your hands on the wheel.

Once through the intersection:

- Continue checking your mirrors for traffic.
- Accelerate smoothly and change gears as necessary.

13.1.3 – Urban Business

During this part of the test, you are expected to make regular traffic checks and maintain a safe following distance. Your vehicle should be centered in the proper lane (right-most lane) and you should keep up with the flow of traffic but not exceed the posted speed limit.

13.1.4 – Lane Changes

During multiple lane portions of the test, you will be asked to change lanes to the left, and then back to the right. You should make the necessary traffic checks first, use proper signals, wait for a safe gap before moving into a lane, and maintain a safe following distance.

13.1.5 – Expressway/Highway

Before entering the expressway:

- Check for traffic.
- Use the proper signals.
- Merge smoothly into the proper lane of traffic.

Once on the expressway:

- Maintain the proper lane positioning, vehicle spacing, and vehicle speed.
- Continue to check for traffic thoroughly in all directions.

When exiting the expressway:

- Make the necessary traffic checks.
- Use the proper signals.
- Decelerate smoothly in the exit lane.
- Once on the exit ramp, continue to decelerate within the lane markings, and maintain adequate spacing between your vehicle and other vehicles.

13.1.6 – Stop/Start

For this maneuver, you will be asked to pull your vehicle over to the side of the road and stop as if you were going to get out and check something on your vehicle. You must check for traffic thoroughly in all directions and move to the right-most lane or shoulder of the road.

As you prepare for the stop:

- Check for traffic.
- Activate your right turn signal.
- Decelerate smoothly, brake evenly, and change gears as necessary.
- Bring your vehicle to a full stop without coasting.

Once stopped:

- The vehicle must be parallel to the curb or shoulder of the road and safely out of the traffic flow.
- The vehicle should not be blocking driveways, fire hydrants, intersections, signs, etc.
- Cancel your turn signal.
- Activate your 4-way emergency flashers.
- Apply the parking brake.
- Move the gear shift to Neutral or Park.
- Remove your feet from the brake and clutch pedals.

When instructed to resume:

- Check your mirrors thoroughly in all directions for traffic.
- Turn off your 4-way emergency flashers.
- Activate the left turn signal.
- When traffic permits, you should release the parking brake and pull straight ahead.
- Do not turn the wheel before your vehicle moves.
- Check traffic from all directions, especially to the left.
- Steer and accelerate smoothly into the proper lane when safe to do so.
- Once your vehicle is back into the flow of traffic, cancel your left turn signal.

13.1.7 – Curve

When approaching a curve:

- Check for traffic thoroughly in all directions.
- Before entering the curve, reduce your speed so further braking or shifting is not required in the curve.
- Keep your vehicle in the lane.
- Continue checking for traffic in all directions.

13.1.8 – Railroad Crossing

Before reaching the crossing, all commercial drivers should:

- Decelerate, brake smoothly, and shift gears as necessary.
- Look and listen for the presence of trains.
- Check for traffic in all directions.
- If multiple lanes, keep vehicle in right most lane.
- Not stop, change gears, pass another vehicle, or change lanes while any part of your vehicle is in the crossing.

If you are driving a bus, school bus, or vehicle displaying placards, you should be prepared to observe the following procedures at every railroad crossing (unless the crossing is exempt):

- As the vehicle approaches a railroad crossing, activate the 4-way emergency flashers.
- Stop the vehicle within 50 feet but not less than 15 feet from the nearest rail.
- Listen and look in both directions along the track for an approaching train and signals indicating the approach of a train. If operating a bus, you may also be required to open the window and door prior to crossing tracks.
- Keep both hands on the steering wheel as the vehicle crosses the tracks.
- Do not stop, change gears, or change lanes while any part of your vehicle is proceeding across the tracks.
- 4-way emergency flashers should be deactivated after the vehicle crosses the tracks.
- Continue to check your mirrors for traffic.

Not all driving road test routes will have a railroad crossing. You may be asked to explain and demonstrate the proper railroad crossing procedures to the examiner at a simulated location.

13.1.9 – Bridge/Overpass/Sign

After driving under an overpass, you may be asked to tell the examiner what the posted clearance or height was. After going over a bridge, you may be asked to tell the examiner what the posted weight limit was. If your test route does not have a bridge or overpass, you may be asked about another traffic sign. When asked, be prepared to identify and explain to the examiner any traffic sign that may appear on the route.

13.1.10 – Student Discharge (School Bus)

If you are applying for a school bus endorsement, you will be required to demonstrate loading and unloading students. Refer to Section 10 of this manual for procedures on loading and unloading school students.

13.1.11 – General Driving Behaviors

You will be scored on your overall performance in the following general driving behavior categories:

Clutch Usage (for Manual Transmission)

- Always use the clutch to shift.
- If equipped with an unsynchronized manual transmission, you must double-clutch when shifting. Do not rev or lug the engine.
- Do not ride the clutch to control speed, coast with the clutch depressed, or “pop” the clutch.

Gear Usage (for Manual Transmission)

- Do not grind or clash the gears.
- Select a gear that does not rev or lug engine.
- Do not shift in turns and intersections.

Brake Usage

- Do not ride or pump the brake.
- Do not brake harshly. Brake smoothly using steady pressure.

Lane Usage

- Do not drive the vehicle over curbs, sidewalks, or lane markings.
- Stop behind stop lines, crosswalks, or stop signs.
- Complete a turn in the proper lane on a multiple lane road (the vehicle should finish a left turn in the lane directly to the right of the center line).
- Finish a right turn in the right-most (curb) lane.
- Move to or remain in the right-most lane unless the lane is blocked.

13.1.12 – Steering

- Do not over or under steer the vehicle.
- Keep both hands on the steering wheel at all times unless shifting. Once you have completed shifting, return both hands to the steering wheel.

13.1.13 – Regular Traffic Checks

- Check for traffic regularly.
- Check your mirrors regularly.
- Check your mirrors for traffic before, while in, and after an intersection.
- Scan and check for traffic in high volume areas and areas where pedestrians are expected to be present.

13.1.14 – Use of Turn Signals

- Use your turn signals properly.
- Activate your turn signals when required.
- Activate your turn signals at appropriate times.
- Cancel your turn signals upon completion of a turn or lane change.

GLOSSARY

Bulk packaging—Packaging, other than a vessel or barge, including a transport vehicle or freight container, in which hazardous materials are loaded with no intermediate form of containment and which has:

1. A maximum capacity greater than 119 gallons (450 L) as a receptacle for a liquid.
 2. A maximum net mass greater than 882 pounds (400 kg) or a maximum capacity greater than 119 gallons (450 L) as a receptacle for a solid.
- OR
3. A water capacity of 1,000 pounds (454 kg) as a receptacle for a gas defined in CFR, Title 49 §173.115.

California Hazardous Waste Manifest—The shipping paper that must accompany all shipments of hazardous waste.

Caltrans—California Department of Transportation.

Carboy—A bottle or rectangular container that holds from 5 to 15 gallons of liquid. Carboys are made of glass, plastic, or metal, and often cushioned in a wooden box.

Cargo tank—A bulk packaging that:

1. Is a tank intended primarily for the carriage of liquids or gases and includes appurtenances, reinforcements, fittings, and closures (for tank, see CFR, Title 49 §§178.3451(c), 178.3371, or 178.3381, as applicable).
2. Is permanently attached to or forms a part of a motor vehicle, or not permanently attached to a motor vehicle but, by reason of its size, construction, or attachment to a motor vehicle is loaded or unloaded without being removed from the motor vehicle.

Carrier—A person engaged in the transportation of passengers or property by:

1. Land or water as a common, contract, or private carrier.
- OR
2. Civil aircraft.

CCR—*California Code of Regulations*—Title 13 and 22.

CFR—*Code of Federal Regulations*—Title 49.

CHP—California Highway Patrol.

CHSC—*California Health and Safety Code*.

CLC—*California Labor Code*.

Compressed gas—Any gaseous material, or liquefied gas, kept in a container under pressure (see more specific Class 2 definitions in CFR, Title 49 §173.115).

Consignee—The business or person to whom a shipment is delivered.

CVC §—*California Vehicle Code* section.

Cryogenic liquid—A refrigerated liquefied gas having a boiling point colder than -130 degrees Fahrenheit at 14.7 psia.

Cylinder—A pressure vessel designed for pressures higher than 40 psia and having a circular cross section. It does not include a portable or cargo tank.

DMV—Department of Motor Vehicles.

DOT—Department of Transportation (federal).

DTSC—Department of Toxic Substance Control.

EPA—U.S. Environmental Protection Agency.

FAA—Federal Aviation Administration.

FHWA—Federal Highway Administration.

FMCSA—Federal Motor Carrier Safety Administration.

FMCSR—Federal Motor Carrier Safety Regulations.

Freight container—A reusable container having a volume of 64 cubic feet or more, designed and constructed to permit being lifted with its contents intact, and intended primarily for containment of packages (in unit form) during transportation.

GCWR—Gross combination weight rating.

Gross weight or mass—The weight of the packaging plus the weight of its contents.

GVW—Gross vehicle weight.

GVWR—Gross vehicle weight rating.

GO PAPERLESS!

Opt-in for paperless notices
for your driver's license, ID card,
or vehicle registration.



Make your selection at
dmv.ca.gov/paperless

GO ONLINE
dmv.ca.gov/online

 *Reduce, reuse, recycle this handbook.*

Hazardous material (HazMat)—A substance or material which has been determined by the U.S. Secretary of Transportation to be capable of posing an unreasonable risk to health, safety, and property when transported in commerce, and which has been so designated. The term includes hazardous substances, hazardous wastes, marine pollutants, elevated temperature materials, and materials designated as hazardous in the Hazardous Materials Table of CFR, Title 49 §172.101 and materials that meet the defining criteria for hazard classes and divisions in CFR, Title 49, Part 173, Subchapter C.

HMR—Hazardous Materials Regulations.

IFTA—International Fuel Tax Agreement.

Infectious substances or etiologic agents—A living microorganism, or its toxin, which may cause human or animal disease.

IRP—International Registration Plan.

Limited quantity—When specified as such in a section applicable to a particular material, it means the maximum amount with specific placarding, labeling, and packaging exceptions.

Marking—The descriptive name, ID number, instructions, cautions, weight, specifications, UN marks, or combinations thereof, required on outer packaging of hazardous materials.

MCP—Motor Carrier Permit.

Mixture—A material composed of more than one chemical compound or element.

Name of contents—The proper shipping name as specified in CFR, Title 49 §172.101.

NHTSA—National Highway Traffic Safety Administration.

N.O.S.—Not otherwise specified.

NTSB—National Transportation Safety Board.

Outage or ullage—The amount by which a packaging falls short of being liquid full, usually expressed in percent by volume. The amount of outage required for liquids in cargo tanks depends on how much the material will expand with temperature changes during transit. Different materials expand at different rates. Enough outage must be allowed so that the tank will not be full at 130 degrees Fahrenheit.

Overpack—An enclosure used by a single shipper to provide protection, convenience in handling of a package, or to combine 2 or more packages. Overpack does not include a transport vehicle or freight container.

Portable tank—Any bulk packaging (except a cylinder having a water capacity of 1,000 pounds or less) designed primarily to be loaded onto, on, or temporarily attached to a transport vehicle or ship and equipped with skids, mountings, or accessories to facilitate handling of the tank by mechanical means. It does not include a cargo tank, tank car, multi-unit tank car tank, or trailer carrying 3AX, 3AAX, or 3T cylinders.

Proper shipping name—The name of the hazardous material shown in Roman print (not italics) in CFR, Title 49 §172.101.

Psi—Pounds per square inch.

Psia—Pounds per square inch absolute.

PUC—Public Utilities Commission.

Registered hazardous waste transporter—Person registered by DTSC who engages in offsite transportation of hazardous waste by air, rail, highway, or water.

Reportable quantity (RQ)—The quantity specified in Column 2 of Appendix A to CFR, Title 49 §172.101 for any material identified in Column 1 of Appendix A.

Shipper's certification—A statement on a shipping paper, signed by the shipper, saying they prepared the shipment properly, according to law. For example:

“This is to certify that the above named materials are properly classified, described, packaged, marked, and labeled, and are in proper condition for transportation according to the applicable regulations of the Department of Transportation.”

OR

“I hereby declare that the contents of this consignment are fully and accurately described above by the proper shipping name and are classified, packaged, marked, and labeled/placarded, and are in all respects in proper condition for transport by (mode of transportation such as rail, aircraft, motor vehicle, or vessel) according to applicable international and national governmental regulations.”

Shipping paper—A shipping order, bill of lading, manifest, or other shipping document serving a similar purpose containing the information required by regulations.

Tank vehicle—Any CMV with any size fixed tank(s) (except tanks necessary for vehicle operation such as air, gas, and oil) or portable tanks of 1,000 gallons or more capacity. Includes any fixed tank in excess of 119 gallons mounted on any vehicle or vehicle combination which requires a CDL or placards.

To transport HazMat or wastes, an “N” endorsement and “H” endorsement are required for a fixed tank(s) regardless of the weight of the vehicle or size of the tank. If the tank is portable and less than 1,000 gallons, only the “H” endorsement is required.

Technical name—A recognized chemical name or microbiological name currently used in scientific and technical handbooks, journals, and texts.

Title 13—*California Code of Regulations*—Motor Vehicles.

Title 22—*California Code of Regulations*—Environmental Health Standards for the Management of Hazardous Waste.

TSA—Transportation Security Administration.

Transport vehicle—A cargo carrying vehicle such as an automobile, van, tractor, truck, semitrailer, tank car, or rail car used for the transportation of cargo by any mode. Each cargo carrying body (trailer, rail car, etc.) is a separate transport vehicle.

Water reactive material—Any material (including sludge and pastes) which when mixed with water, is likely to ignite or give off flammable or toxic gases in dangerous quantities. Water reactive material is required to be labeled DANGEROUS WHEN WET.

PURCHASE OF REFERENCE MATERIALS

A CVC book may be viewed online at leginfo.legislature.ca.gov or purchased at any DMV field office.

California regulations relating to commercial vehicles are contained in CCR, Title 13 and may be purchased from Barclays at barclaysccr.com or by calling 1-800-888-3600.

Copies of the CFR, Title 49 or CCR, Title 22, Division 4.5 may be purchased from the U.S. Government Bookstore by calling the Government Publishing Office at 1-866-512-1800.

DISCLAIMER

When using this handbook, remember that it is only a summary of the laws and regulations.

DMV, law enforcement, and courts follow the full and exact language contained in the CVC.

WHERE TO WRITE

Questions or comments regarding this handbook may be addressed to:

Department of Motor Vehicles
Customer Communications Unit, MS H165
PO Box 932345
Sacramento, CA 94232-3450

**THIS PAGE LEFT
INTENTIONALLY
BLANK**

**THIS PAGE LEFT
INTENTIONALLY
BLANK**